

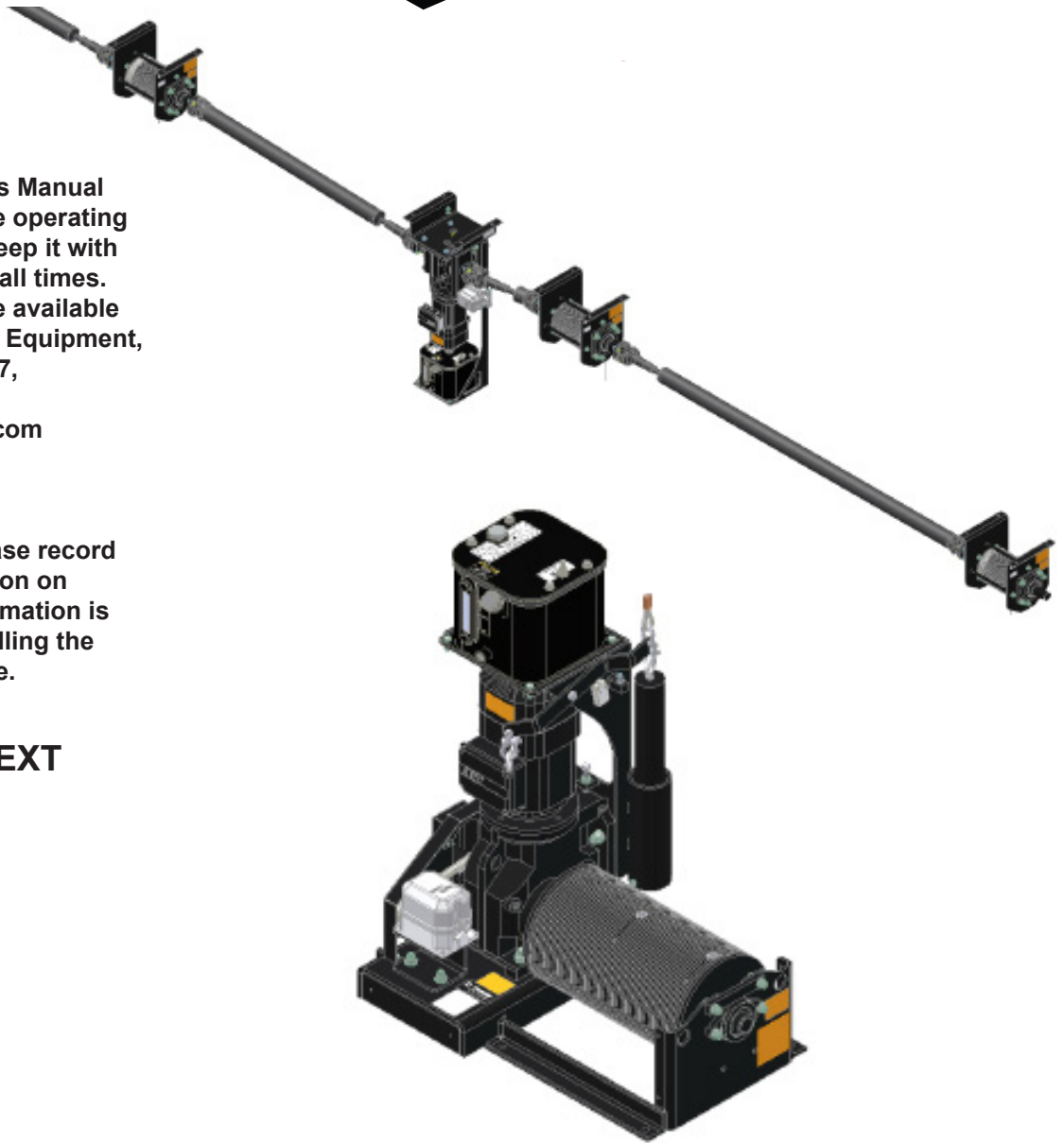

Read this Owner's Manual thoroughly before operating the equipment. Keep it with the equipment at all times. Replacements are available from Thern Stage Equipment, Winona, MN 55987, 800-553-2204. www.thernstage.com

IMPORTANT: Please record product information on page 2. This information is required when calling the factory for service.

ORIGINAL TEXT



Owner's Manual

For
Fire Curtain
Lineshaft and Drum Hoists

Two-Year Limited Warranty

Please record the following:

Date Purchased: _____

Model No.: _____

Serial No.: _____

This information is required when calling the factory for service.

Thern, Inc. warrants its products against defects in material or workmanship for two years from the date of purchase by the original using buyer, or if this date cannot be established, the date the product was sold by Thern, Inc. to the dealer. To make a claim under this warranty, contact the factory for an RGA number. The product must be returned, prepaid, directly to Thern, Inc., 5712 Industrial Park Road, Winona, Minnesota 55987. The following information must accompany the product: the RGA number, the date of purchase, the description of the claimed defect, and a complete explanation of the circumstances involved. If the product is found to be defective, it will be repaired or replaced free of charge, and Thern, Inc. will reimburse the shipping cost within the contiguous USA.

This warranty does not cover any damage due to accident, misuse, abuse, or negligence. Any alteration, repair or modification of the product outside the Thern, Inc. factory shall void this warranty. This warranty does not cover any costs for removal of our product, downtime, or any other incidental or consequential costs or damages resulting from the claimed defects. This warranty does not cover brake discs, wire rope or other wear components, as their life is subject to use conditions which vary between applications.

FACTORY AUTHORIZED REPAIR OR REPLACEMENT AS PROVIDED UNDER THIS WARRANTY IS THE EXCLUSIVE REMEDY TO THE CONSUMER. THERN, INC. SHALL NOT BE LIABLE FOR ANY INCIDENTAL OR CONSEQUENTIAL DAMAGES FOR BREACH OF ANY EXPRESS OR IMPLIED WARRANTY ON THIS PRODUCT. EXCEPT TO THE EXTENT PROHIBITED BY APPLICABLE LAW, ANY IMPLIED WARRANTY OF MERCHANTABILITY OR FITNESS FOR A PARTICULAR PURPOSE ON THIS PRODUCT IS LIMITED IN DURATION TO THE DURATION OF THIS WARRANTY.

Some states do not allow the exclusion or limitation of incidental or consequential damages, or allow limitations on how long an implied warranty lasts, so the above limitation or exclusion may not apply to you. This warranty gives you specific legal rights, and you may also have other rights which vary from state to state.

Note: Thern, Inc. reserves the right to change the design or discontinue the production of any product without prior notice.

About This Manual

The Occupational Safety and Health Act of 1970 states that it is the employer's responsibility to provide a workplace free of hazard. To this end, all equipment should be installed, operated, and maintained in compliance with applicable trade, industrial, federal, state, and local regulations. It is the equipment owner's responsibility to obtain copies of these regulations and to determine the suitability of the equipment to its intended use.

This Owner's Manual, and warning labels attached to the equipment, are to serve as guidelines for hazard-free installation, operation, and maintenance. They should not be understood to prepare you for every possible situation.

Information contained in this Owner's Manual is applicable only to Thern Fire Curtain Lineshaft and Drum Hoists. Do not use this manual as a source of information for any other equipment.

The following symbols are used for emphasis throughout this manual:

▲WARNING

Failure to follow 'WARNING!' instructions may result in equipment damage, property damage, and/or serious personal injury.

▲CAUTION

Failure to follow 'CAUTION!' instructions may result in equipment damage, property damage, and/or minor personal injury.

Important!

Failure to follow 'Important!' instructions may result in poor performance of the equipment.

Suggestions for Safe Operation

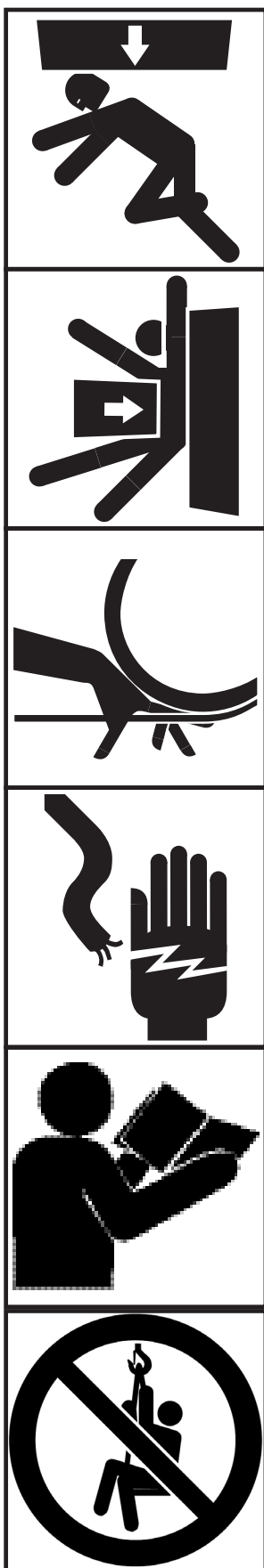

⚠WARNING

DO the following:

Read and comply with the guidelines set forth in this Owner's Manual. Keep this manual, and all labels attached to the hoist, readable and with the equipment at all times. Contact Thern, Inc. for replacements.

Check lubrication before use.

Install the wire rope securely to the hoist drums.

Keep at least 4 wraps of wire rope wound on the drums at all times, to serve as anchor wraps. With less than 4 wraps on the drum the wire rope could come loose, causing the load to escape.

Keep hands away from the drums, gears, wire rope, and other moving parts of the equipment.

Keep all unnecessary personnel away from hoist while in operation. Keep out of the path of wire rope that might snap back and cause injury if broken.

Disconnect electric power before servicing the equipment.

DO NOT do the following:

This product designed for lifting and moving material only. Do not use this product for any other purpose.

Do not exceed the load rating of the hoist or any other component in the system. To do so could result in failure of the equipment.

Do not use more than one hoist to move a load unless each hoist was designed for use in a multiple hoist system.

Do not use damaged or malfunctioning equipment. To do so could result in failure of the equipment.

Do not modify the equipment in any way. To do so could cause equipment failure.

Do not wrap the wire rope around the load. This damages the wire rope and could cause the load to escape. Use approved rigging connectors to secure the wire rope to the load.

Do not operate the hoist with drive guards or gear covers removed or improperly installed.

Do not divert your attention from the operation. Stay alert to the possibility of accidents, and try to prevent them from happening.

Do not jerk or swing the load. Avoid shock loads by starting and stopping the load smoothly. Shock loads overload the equipment and may cause damage.

Do not adjust the brake with the hoist holding a load. Accidental release of the brake could result in loss of the load.

1.1 Installing the Hoist

Important!

- Inspect the hoist immediately following installation according to the Instructions for Periodic Inspection. This will give you a record of the condition of the hoist with which to compare future inspections.
- A qualified professional should inspect or design the foundation to insure that it will provide adequate support.
- When positioning the hoist use the lifting holes provided or a sling wrapped around drum and/or reducer assembly.
- Do not attempt to lift or position hoist by using lifting hole on reducer. This hole is designed to lift reducer only.
- Do not weld the hoist frame to the foundation or support structure. Welding the frame may void warranty, contact Thern, Inc. Use fasteners as instructed.

⚠WARNING

Do not install the hoist in an area defined as hazardous by the National Electric Code, unless installation in such an area has been thoroughly approved.

Do not install the hoist near corrosive chemicals, flammable materials, explosives, or other elements that may damage the hoist or injure the operator. Adequately protect the hoist and the operator from such elements.

Attach the hoist to a rigid and level foundation that will support the hoist and its load under all load conditions, including shock loading.

Lineshaft hoists are designed for vertical lifting only. Lift lines must be connected directly to the load.

- 1.1.1 CONSULT APPLICABLE CODES AND REGULATIONS for specific rules on installing the equipment.
- 1.1.2 LOCATE THE HOIST in an area clear of traffic and other obstacles. Make sure the hoist is accessible for maintenance and operation.
- 1.1.3 LOCATE THE HOIST in an area with adequate temperatures. Check the motor and reducer manufacturer's information for ambient temperature ratings.
- 1.1.4 POSITION THE HOIST to allow access for proper lubrication.
- 1.1.5 INSTALL THE HOIST on a horizontal surface. The hoist is designed and assembled for a specific installation orientation, as specified at time of order.
- 1.1.6 MAINTAIN A FLEET ANGLE of less than 2 degrees. The proper fleet angle minimizes wire rope damage by helping the wire rope wind properly into the grooves on the drum. See Figure 1.
- 1.1.7 FASTEN THE HOIST SECURELY to the foundation.
- a For Standard products referred to in this manual, use coarse thread fasteners, grade 5 or better. Be sure to check the torque required for your fastener selection before mounting hoist. Make sure the hoist is secured to a solid foundation able to support the hoist and the load under all conditions with design factors based on accepted engineering practices.
 - b Non-standard products that vary from the original design may have different fastening requirements. Contact a structural engineer or Thern, Inc. for this information.

CONTACT A QUALIFIED PROFESSIONAL FOR MOUNTING INSTRUCTIONS TO COMPLY WITH LOCAL CODES.

1.2 Installing the Breather Plugs

Important!

- Save the sealed plug for use when the hoist is removed for storage or transport.

CAUTION

Install the breather plug to vent heat and pressure. Failure to do so could result in pressure buildup which could damage the reducer or prevent the Hydraulic Retarder from operating correctly.

For shipment, the reducer is filled with lubricant and sealed to prevent lubrication loss.

SEW Eurodrive reducers are supplied with the breather plug installed. Before operation the black rubber seal located on the breather plug **MUST BE REMOVED**. Refer to the reducers manufacturer's instructions. **Motovario reducers are maintenance free and do not require a breather.**

Some units supplied may not have a breather plug installed for shipment. Install the breather plug before operation.

- 1.2.1 REMOVE THE SEALED PLUG from the breather plug hole (if applicable).
- 1.2.2 CHECK THE LUBRICANT LEVEL in the reducer to make sure no lubricant was lost during shipment. Refer to the reducer manufacturer's instructions.
- 1.2.3 INSTALL THE REDUCER BREATHER PLUG. The breather plug is wired to the reducer and retarder or attached in a plastic bag. Refer to the reducer manufacturer's information.
- 1.2.4 INSTALL RETARDER BREATHER PLUG. See Section 1.4 Setting up the motor unit.

Figure 1 – Maintaining the Fleet Angle

Control fleet angle by connecting wire rope in such a way that it is straight vertical at high trim.

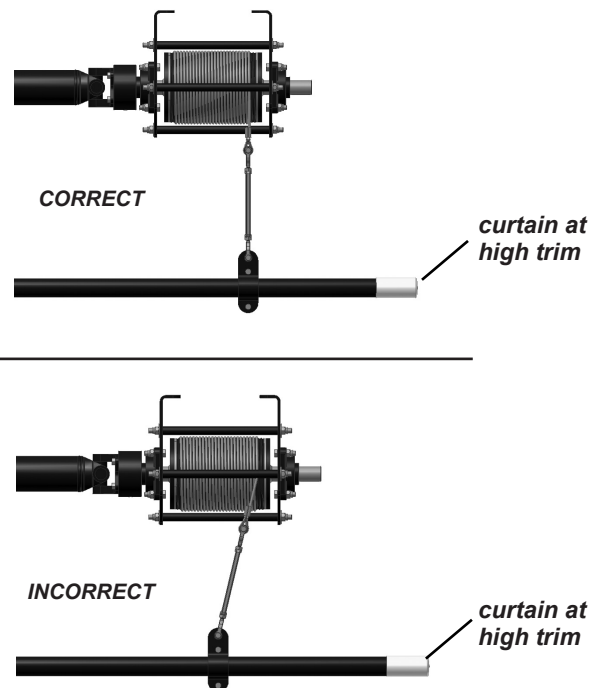

1.3 Connecting Electric Power

Important!

- Use electrical equipment with the correct rating and Underwriter's Laboratory (UL) approved.
- Always disconnect electric current when the hoist is not in use.

⚠WARNING

Install proper branch circuits, disconnect devices, protection, and grounding as required by article 430 of the National Electric Code.

All electrical work must be performed by a licensed electrician. Failure to do so could result in electric shock or poor hoist operation.

All control devices must be momentary contact type. Install all control devices so the hoist motor will stop when the operator releases the device.

Locate control devices so the operator will be able to view the load through the entire operation.

Locate control devices so the operator will be clear of the load, the wire rope, and the path of wire rope that could snap back and cause injury if broken.

It is the responsibility of the owner to provide equipment for controlling the hoist. Electrical control packages are available from Thern. The following guidelines are supplied as a reference for the installer.

- 1.3.1 CONSULT APPLICABLE CODES AND REGULATIONS for specific rules on electrical installation.
- 1.3.2 CHECK THE COMPONENT MANUFACTURER'S INSTRUCTIONS for installing and connecting the motor, brake, and other equipment.
- 1.3.3 INSTALL A FUSE or circuit breaker in the power supply circuit, as required by the National Electric Code.
- 1.3.4 INSTALL A DISCONNECT DEVICE in the power supply circuit, as required by the National Electric Code. This should be a switch you can lock in the OFF position to prevent unauthorized use of the hoist.
- 1.3.5 CONNECT ELECTRIC STARTER CONTROLS to the motor. **Make sure the load brake is wired for fast braking on brakemotors that offer this function.** Check the component manufacturer's information.
- 1.3.6 CONNECT ELECTRIC POWER SUPPLY, with ground wire, to the electric starter control box. Check the component manufacturer's information for a wiring diagram.
- 1.3.7 CONNECT PRIMARY MOTOR BRAKE INTERLOCK to disable the hoist, if the release line has been triggered..
- 1.3.8 CONNECT OTHER ELECTRIC EQUIPMENT to the proper terminals in the electric control box.
- 1.3.9 CHECK THE CURRENT at the motor and make sure it agrees with the current rating marked on the hoist nameplate. If current rating is incorrect, have the circuit inspected by a licensed electrician.
- 1.3.10 TEST ELECTRICAL CONNECTIONS, when provided, by operating the hoist.
 - a ROTATION OF THE DRUM must agree with the labels on the control device, either UP or DOWN.
 - b CHECK THE LOAD BRAKE, make sure it releases when the motor is ON, and engages when the motor is OFF. **Make sure the fast brake function operates correctly on brakemotors that include this feature.**

CONTACT THE FACTORY OR A QUALIFIED PROFESSIONAL FOR HELP.

1.4 Setting Up the Motor Unit

⚠WARNING

Do not operate without filling the hydraulic reservoir with DTE 24 or 25 hydraulic fluid. Reservoir is not filled at factory for shipping.

- 1.4.1 REMOVE BREATHER FILL PLUG, if already installed, to fill hydraulic reservoir with DTE 24, typically supplied with motor assembly, to within operating range showed on label next to sight glass. Once properly filled, install filler/Breather plug. See Figure 2A.
- 1.4.2 ENSURE RETARDER is set to correct motor rotation. See figure 2B.
- 1.4.3 REEVE fire curtain release line as needed and hook to shackle provided on brake release arm. Make sure there is enough tension on the line to lift the weight to set the brake on the motor assembly.
- 1.4.4 MAX WEIGHT DROP ADJUSTMENT is set at the factory This is to reduce the weight that the brake arm lever will see and prevent it from braking when the weight is dropped.
- 1.4.5 ADJUST BRAKE RELEASE SENSOR SWITCH so it trips when the release line is triggered and the brake releases. See figure 2A.
- 1.4.6 ADJUST FLOW CONTROL VALVE to achieve the speed applicable for the governing code in your area. Loosen jam nut on adjusting screw. Turn screw counter-clockwise to increase speed (reduce time), clockwise to decrease speed (increase time). Once proper speed is achieved, tighten jam nut while holding adjusting screw stationary.

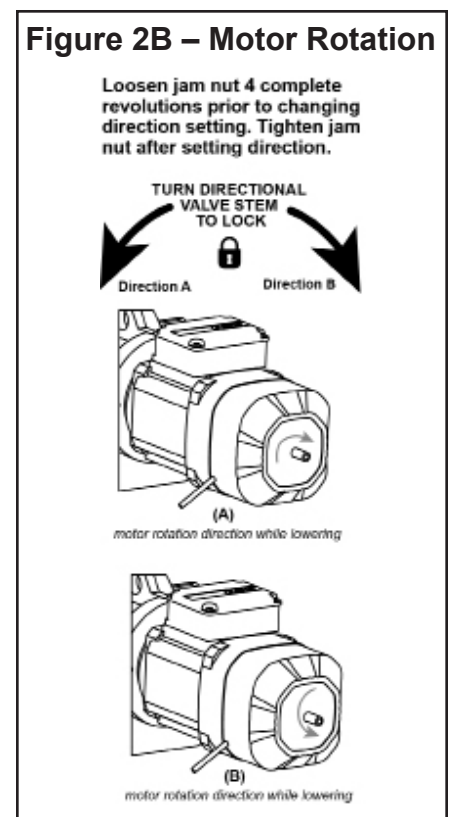
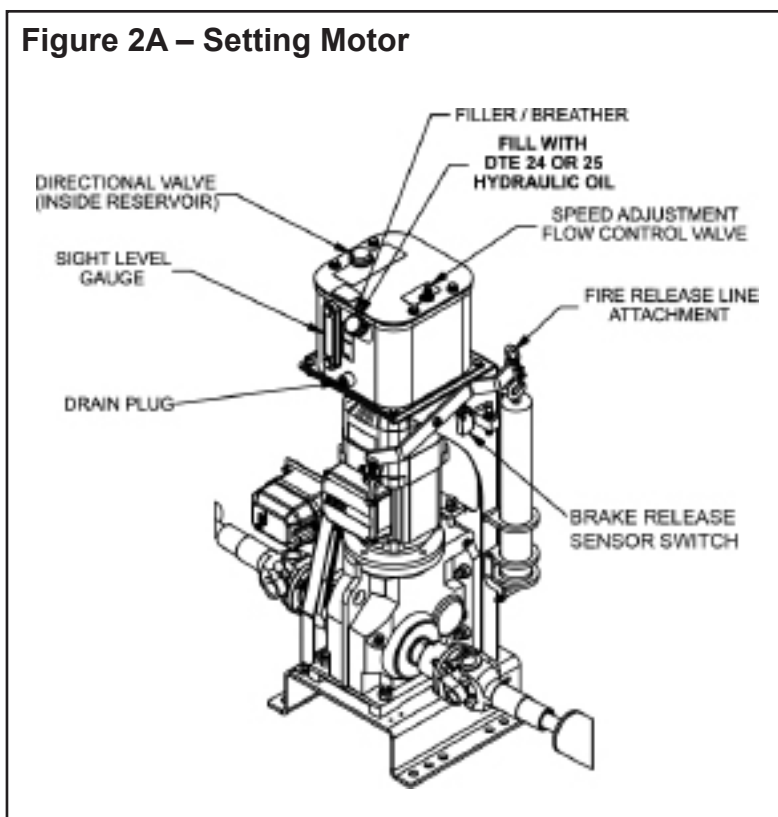

1.5 Installing the Wire Rope

Important!

- Use wire rope and other rigging equipment rated for the size of the largest load you will be moving.
- Do not drag the wire rope through dirt or debris that could cause damage, or poor operation.
- Always wear protective clothing when handling wire rope.

⚠WARNING

Install the wire rope securely to the hoist drum. A poorly secured wire rope could come loose from its anchor and allow the load to escape.

Install the wire rope so it is wound correctly as shown or the hoist and brake will not work properly, and could allow the load to escape, see Figure 3.

- 1.5.1 PURCHASE THE PROPER WIRE ROPE for your application. Keep the following in mind when selecting a wire rope. Contact a reputable wire rope supplier for help.
- BREAKING STRENGTH of new wire rope should be at least 8 times greater than the largest load placed on the hoist. This is a minimum value and will vary with the type of load and how you are moving it.
 - WIRE ROPE LAY must agree with the winding direction of the drum to help insure proper winding.
 - WE RECOMMEND 7 x 19 galvanized aircraft cable for diameters up to 5/16 inch.
- 1.5.2 ANCHOR THE WIRE ROPE to the drum using the key slot anchor.
- PASS THE WIRE ROPE under the drum and position the anchor fitting in the key slot in the drum.
 - PULL THE WIRE ROPE to firmly lodge the anchor fitting in the narrowest part of the key slot. Make sure the wire rope remains securely anchored as wire rope is wound onto the drum. See Figure 3.
 - INSTALL pipe plug into slot hole to prevent wire rope from escaping drum slot (for models equipped with this feature).
- 1.5.3 WIND FOUR FULL WRAPS of wire rope onto the drum by operating the hoist while holding the wire rope taught. **These wraps serve as anchor wraps and must remain on the drum at all times.**

Figure 3 – Installing the Wire Rope – Key Slot Anchor

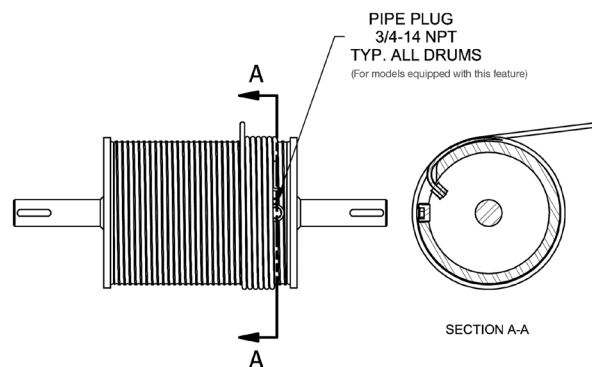

correct

install wire rope in proper direction as shown to securely anchor the rope in the key slot anchor

1.6 Setting Travel Limits

CAUTION

Limit set points are dependant on speed of operation. Use caution with setting limits on units with variable speed operation. Typically, limits should be for the highest speed to be encountered.

Correct setup may take some trials and adjustments.

Standard units are shipped with either **TER** or **Stromag** limit switches. For units equipped with other limit switches, refer to manufacturer's instructions.

Each unit's travel is controlled by two sets of limit switches driven from the gear box output shaft. One set controls the normal movement (normal limit) of the unit. The other set (over-travel limit) is there to indicate an over travel in the event of a failure to the normal limits.

The overtravel limits should be set first to determine the absolute maximum range of travel that the unit is able to run securely. The travel limits should be set within this range to limit the movement of the normal operating range. The over-travel limits should never engage during normal operation.

Figure 4 – Setting TER Travel Limits

Switch	Typical Position*	Travel
4	Up	Over
3	Up	Normal
2	Down	Normal
1	Down	Over

*Typical connection for upright hoist. Refer to drawings for specific orientation and contacts.

Important!

- If overtravel limits are struck during operation, contact Thern for more information.

- 1.6.1 **SET TER LIMITS** by doing the following: **Overtravel limits should be set before travel limits. See Figure 4.**
- a REMOVE the limit switch cover.
 - b DETERMINE WHICH DIRECTION the limit switch cam rotates when the UP button is pressed.
 - c ROTATE THE DRUM in one direction to the full extent of its travel. NOTE: Always operate the hoist in the direction of travel that it will be traveling when it strikes the limit.
 - d ADJUST THE OVER-TRAVEL LIMIT for that direction so that any additional rotation of the drum in that direction would strike the over-travel limit. This will set the maximum range of travel that the unit is able to run securely.
 - d.1 LOOSEN the large locking screw in the center of the column. Failure to loosen locking screw prior to adjusting limit cams may result in damage to the RLS.
 - d.2 TURN THE APPROPRIATE ADJUSTMENT SCREW so that the microswitch is hit by the cam as the load moves to the desired position.
 - d.3 TIGHTEN the large locking screw in the center of the column. Failure to tighten the locking screw prior to operating the hoist may result in limit losing its setting.
- NOTE: Bypass the OT to run off the OT limit in order to adjust and set additional limits.**
- e ADJUST THE NORMAL LIMIT for that direction to engage the switch element following steps d.1 through d.3.
 - f ROTATE THE DRUM in the opposite direction to the full extent of its travel and repeat steps D through E.
 - g TRAVEL THE UNIT to both extremes and verify that the normal limits stop the unit without engaging the over-travel limits.
 - h REPLACE the cover.

Figure 5 – Setting Stromag Travel Limits

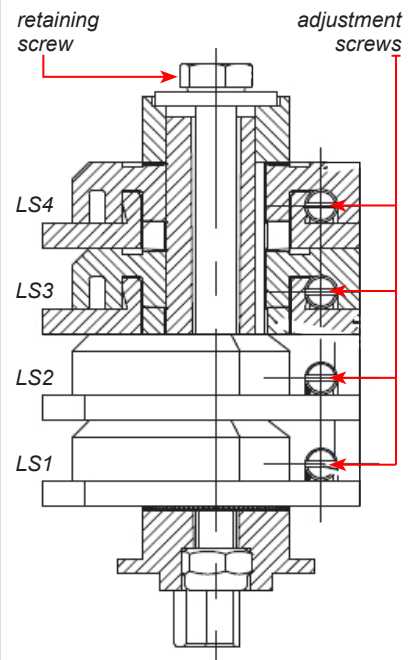

Switch	Typical Position*	Travel
4	Up	Over
3	Up	Normal
2	Down	Normal
1	Down	Over

*Typical position for upright hoist with upright RLS. Refer to drawings for specific orientation and contacts.

1.6.2 **SET STROMAG LIMITS** by doing the following. **Overtravel limits should be set before travel limits. See Figure 5.**

- a REMOVE the limit switch cover.
- b DETERMINE WHICH DIRECTION the limit switch cam rotates when the UP button is pressed.
- c ROTATE THE DRUM in one direction to the full extent of its travel.
- d ADJUST THE OVER-TRAVEL LIMIT for that direction so that any additional rotation of the drum in that direction would strike the over-travel limit. This will set the maximum range of travel that the unit is able to run securely.

NOTE: Bypass the OT to run off the OT limit in order to adjust and set additional limits.

- e ADJUST THE NORMAL LIMIT for that direction to engage the switch element.
- f ROTATE THE DRUM in the opposite direction to the full extent of its travel and repeat steps D through E for the remaining limits.
- g TRAVEL THE UNIT to both extremes and verify that the travel limits stop the unit without engaging the over-travel limits.
- h REPLACE the cover.

NOTE: In the event an over-travel limit is struck, determine the cause for the over-travel limit being struck and contact Thern or a qualified service technician to enact bypass procedures.

2.1 General Theory of Operation

Important!

- Limit nonuniform winding by keeping tension on the wire rope and by maintaining the proper fleet angle.
- To help insure rated performance, make sure voltage at the motor is equal to the motor's voltage rating.
- It is your responsibility to detect and account for different factors affecting the condition and performance of the equipment.

- 2.1.1 THE FORCE REQUIRED to move the load must not exceed the load rating of the hoist. Consider the total force required to move the load, not the weight of the load.
- 2.1.2 THIS EQUIPMENT CAN develop forces that will exceed the load rating. It is the responsibility of the equipment user to limit the size of the load. Inspect the equipment regularly for damage according to the instructions contained in this manual and in the component manufacturer's information.
- 2.1.3 PRIMARY MOTOR LOAD BRAKE provides positive load holding and should be used at all times. **Do not depend on hoist gearing to hold the load in place.**
- 2.1.4 PERFORMANCE RATINGS of the equipment are determined by the design of the hoist.
- a LINE SPEED is the speed that the load will travel. The weight of the load does not affect line speed.
- b LOAD RATING represents the maximum pull that can be placed on new equipment.
- 2.1.5 DUTY RATINGS refer to the type of use the equipment is subject to. Consider the following when determining duty rating.
- a ENVIRONMENT: harsh environments include hot, cold, dirty, wet, corrosive, or explosive surroundings. **Protect the equipment from harsh environments when possible.**
- b MAINTENANCE: poor maintenance, meaning poor cleaning, lubrication, or inspection, leads to poor operation and possible damage of the equipment. **Minimize poor maintenance by carefully following the instructions contained in this manual.**
- c LOADING: severe loading includes shock loading and moving loads that exceed the load rating of the equipment. **Avoid shock loads, and do not exceed the load rating of the equipment.**
- d FREQUENCY OF OPERATION: frequent start and stop functions increase wear and shorten the life span of the gear train and load brake components. Lengthy operations cause lubrication to become hot, which also decreases the life span of the gear train. **Increase maintenance of the equipment if used in frequent operations.**
- 2.1.6 RETARDER SYSTEM.
- a WHEN THE BRAKE IS RELEASED, the fire curtain is allowed to freely accelerate to a set speed. This speed can be adjusted, but it is recommended that this only be performed by personnel trained by Thern in the process. **Failure to abide by this may result in voiding the warranty and damage or injury if the curtain is released in an emergency.**
- b WHEN THE RELEASE SYSTEM IS TRIGGERED, THE CURTAIN WILL ACCELERATE until the maximum set speed is reached. Once the set speed is reached, the curtain will maintain that speed until it comes to rest in the closed position.

CONTACT THE FACTORY FOR MORE INFORMATION.

2.2 Breaking-In the Hoist

- 2.2.1 BREAK-IN OCCURS during the first few hours of normal operation. During break-in, mating surfaces become polished, and clearances increase. This is desired for efficient operation of bearings and gears.
- 2.2.2 INSPECT THE HOIST following break-in according to the Instructions for Periodic Inspection. See section 3.5 Inspecting the Equipment.

Important!

- When determining whether the load will exceed the load rating, consider the total force required to move the load.

2.3 Preparing for Operation

- 2.3.1 CONSIDER THE OPERATION. Do not begin until you are sure you can perform the entire operation without hazard.
- 2.3.2 BEFORE INITIAL OPERATION inspect the hoist and all components of the system according to Instruction for Frequent Inspection.
- 2.3.3 BEFORE EACH OPERATION inspect all components of the system.
- a OPERATORS must be in good health, alert, thoroughly trained in operating the equipment, and properly clothed (safety equipment as required, no loose clothing, no loose jewelry).
- b THE LOAD must be clear of other objects and free to move. Make sure the load will not tip, bind, or in any way move uncontrollably.
- 2.3.4 KNOW YOUR LOAD and make sure you do not exceed the load rating of the hoist or any other equipment in the system.

Important!

- Obey a stop signal from anyone.
- Maintain tension on the wire rope to keep it tightly and evenly wound on the drum.
- If the hoist and load are not visible during the entire operation, get help from another person.
- Appoint a supervisor if more than one person is involved in the operation. This will reduce confusion and increase safety.

2.4 Moving the Load

- 2.4.1 MOVE THE LOAD slowly and smoothly, only a small distance at first. Make sure the load is balanced and securely attached before continuing.
- 2.4.2 USE THE CONTROL DEVICE to operate the hoist. The control device should be momentary contact type, so the hoist will stop when the operator releases the control.
- 2.4.3 OBSERVE THE WIRE ROPE as it winds onto the drum. If it becomes loose, uneven, or overlapped, stop the operation and rewind the wire rope before continuing. **Continued operation with overlapped or uneven wire rope can damage the wire rope and shorten its life.**
- 2.4.4 OBSERVE THE REDUCER during operation for signs of overheating. **Frequent overheating may be a sign of damage, or may indicate the need for a larger power hoist.**
- a WATCH FOR SMOKE, the smell of burnt lubricant, and other signs of overheating. Use a thermocouple or other device to monitor reducer temperature.
- b STOP THE OPERATION if the reducer overheats, and allow the hoist to cool. **Continued operation may cause damage.**

Important!

Increase the frequency of maintenance procedures if the hoist is:

- Operated for long periods.
- Used to lift heavy loads.
- Operated in wet, dirty, hot, or cold surroundings.

3.1 Cleaning the Hoist

Clean the hoist to remove dirt and help prevent rust and corrosion.

- 3.1.1 CLEAN THE HOIST at least annually or whenever it is dirty, per application or environment equipment is in.
 - a WIPE ALL EQUIPMENT to remove dirt and grease.
 - b LEAVE A LIGHT FILM of oil on all surfaces to protect them against rust and corrosion.
 - c WIPE OFF excessive amounts of oil to avoid the accumulation of dirt.
- 3.1.2 REMOVE ALL UNNECESSARY OBJECTS from the area around the hoist.

3.2 Adjusting the Brakes

⚠WARNING

Do not adjust the brake with the load suspended. Accidental release of the brake could allow the load to escape.

- 3.2.1 CHECK THE BRAKES by operating the hoist with a load equal to the hoist load rating.
 - a RAISE THE LOAD, then lower it and stop it about one foot off the ground.
 - b OBSERVE THE LOAD when stopped.
 - c REFER TO BRAKE manufacturer's instructions

3.4 Lubricating the Hoist

▲CAUTION

Make sure the breather plugs are clean and open to vent heat and pressure. Poor ventilation may cause overheating and result in damage to oil seals and other equipment.

Fill the reducer to the proper level without overfilling. Too much or too little lubricant will cause overheating and result in damage to seals, bearings, and gears.

The retarder is an entirely closed system contained within the reservoir to limit leak points. Opening the reservoir may result in loss of warranty unless performed by a properly trained technician.

Hoists are shipped pre-filled with lubricant.

Lubricate the hoist properly to help protect it from wear and rust. Read the following instructions carefully.

- 3.4.1 MOTOR BEARINGS are typically lubricated for life by the manufacturer. Some motors require periodic lubrication. Refer to the motor manufacturer's information for specific instructions.
- 3.4.2 LUBRICATE THE REDUCER according to the manufacturer's instructions.
- CHECK OIL LEVEL monthly. Remove the level plug and make sure oil is even with the plug hole.
 - FILL THE REDUCER according to the manufacturer's instructions. Fill the reducer until oil reaches the level plug. **Do not mix different lubricants.**
 - CHANGE REDUCER LUBRICANT at least every 12 months, or whenever it is dirty or contaminated.
- 3.4.3 LUBRICATE FLANGE BEARING monthly. Insert NLGI #2 EP (Extreme Pressure) grease through the grease zerk. Refer to the bearing manufacturer's information for specific instructions. See Figure 6.
- 3.4.4 THE RETARDER may require draining periodically for storage or transport.
- TO DRAIN THE RETARDER, a drain plug has been supplied at the low end of the reservoir. A fill plug is located on the front of the reservoir. Arrange to capture the oil in a proper drain pan or container. See Figure 2A.
 - REMOVE THE FILL PLUG, and then the drain plug and allow the oil to flow into a containment vessel. When oil no longer flows out, replace the drain plug and clean any excess drippage from the reservoir. If the unit is to be transported, replace the fill plug to prevent any contaminants from entering the reservoir.
 - TO REFILL THE RETARDER, fill with the proper hydraulic fluid as specified elsewhere in the manual until the oil level is within the range shown on sight label. Then replace the fill plug.
- 3.4.5 LUBRICATE THE WIRE ROPE by following the wire rope manufacturer's recommendations.
- 3.4.6 LUBRICATE THE ROTARY LIMIT SWITCH DRIVE CHAIN monthly or as often as necessary to prevent the moving contact surfaces from becoming dry. If needed, remove the guard to gain access to the chain. Brush high-grade SAE 20 oil on to the chain leaving a light oil film along the entire length. RE-INSTALL the guard when completed.
- 3.4.7 LUBRICATE DRIVE SHAFTS, if applicable, by following the drive shaft manufacturer's recommendations.

Important!

- Do not leave plug holes in the reducer open. Open plug holes will allow dirt and moisture to contaminate the lubrication.
- Make sure lubricant has a temperature rating appropriate for the ambient temperatures of the operation.
- Replace the motor bearings if the motor is disassembled for any reason.

Figure 6 – Lubricating the Flange Bearing

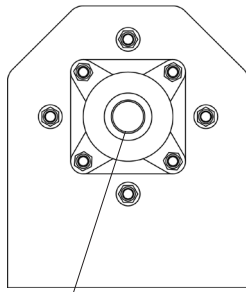

*flange bearing,
lubricate with NLGI
no. 2EP grease*

Figure 7 – Lubricating the Rotary Limit Switch Drive Chain

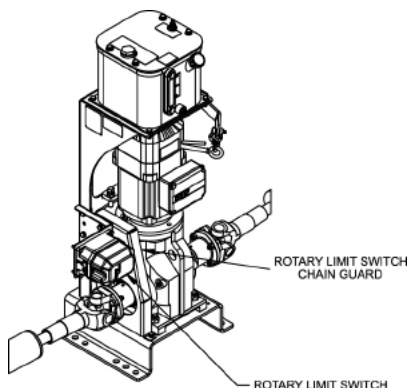

**Use DTE 24 or 25 Hydraulic Fluid*

3.5 Inspecting the Equipment

Important!

- Start an inspection program as soon as you put the hoist into use.
- Appoint a qualified person to be responsible for regularly inspecting the equipment.
- Keep written records of inspection. This allows comparison with comments from previous inspections so you can see changes in condition or performance.

Perform frequent inspections:

- Before initial operation.
- Monthly during operation.
- Whenever you notice signs of damage or poor operation.

Frequent Wire Rope Inspection:

- Use ASME B30.7 as a guideline for rope inspection, replacement and maintenance.
- Check the wire rope, end connections and end fittings for corrosion, kinking, bending, crushing, bird-caging or other signs of damage.
- Check the number, distribution and type of visible broken wires. See paragraph 3.5.4. c and Figure 8.
- Check the wire rope for reduction of rope diameter from loss of core support, or wear of outside wires. See Figure 9.
- Take extra care when inspecting sections of rapid deterioration such as sections in contact with saddles, sheaves, repetitive pickup points, crossover points and end connections.

⚠WARNING

Do not use damaged or malfunctioning equipment. Place an “OUT OF ORDER” sign on the hoist. Do not use the hoist until the sign is removed by a qualified maintenance person who has completely corrected the problem.

Inspect the hoist to detect signs of damage or poor operation before they become hazardous. See Table 1 - Inspection Checklist.

3.5.1 CONSULT APPLICABLE CODES AND REGULATIONS for specific rules on inspecting the hoist and other equipment.

3.5.2 CHECK COMPONENT MANUFACTURER’S INSTRUCTIONS for inspecting the motor, brake, reducer, bearings, wire rope, and other equipment.

3.5.3 Instructions for Frequent Inspection

- a VISUALLY INSPECT the entire hoist and all other equipment involved in the operation.
 - Check all equipment for cracks, dents, bending, rust, wear, corrosion and other damage.
 - Make sure the wire rope is installed correctly and anchored securely to the drum.
 - Check the reducer for signs of leakage.
 - Make sure the entire hoist is properly lubricated.
 - Make sure the breather plug is clean, open, and installed correctly.
 - Make sure mounting fasteners are tightened securely.
 - Make sure the foundation is in good condition, and capable of supporting the hoist and its load under all load conditions.
 - Check electrical wiring and connections for wear, corrosion, cuts, and other damage.
- b TEST HOIST PERFORMANCE by operating the hoist with a load not exceeding the load rating.
 - Listen for unusual noises, and look for signs of damage as you operate the hoist.
 - Make sure the wire rope winds evenly and tightly onto the drum. If it is loose or uneven, rewind it before continuing.
 - Make sure the load moves smoothly, without hesitation or strain.
 - Make sure the hoist responds to the control device. It must rotate as shown on the control labels, and it must turn off when you release the control.
 - Verify hoist lowering set speed of retarder.
 - Check the motor brake. Raise the load, then lower it and stop it a few feet off the ground. If the load continues to coast or creep, the brake needs adjustment. Refer to brake manufacturer’s instructions.

Completely correct all problems before continuing. Use the Troubleshooting Chart to help determine the cause of certain problems. See Table 2.

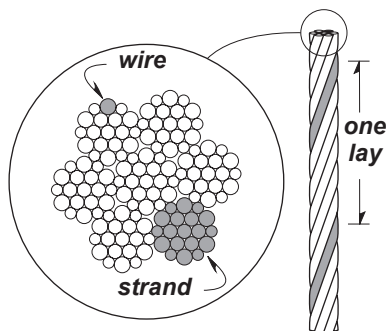
Figure 8 – Broken Wires

Wire rope assembly must be replaced if more than 6 wires are broken in one lay, or if more than 3 wires are broken in one strand in one lay.

Perform periodic inspections:

- Every 12 months.
- Whenever you return the hoist to service from storage.
- Whenever you notice damage or poor operation in a frequent inspection.
- Whenever you have, or think you may have, overloaded or shock loaded the hoist.

3.5.4 Instructions for Periodic Inspection

- a VISUALLY INSPECT the hoist and all other equipment.
 - Check the finish for wear, flaking, or other damage.
 - Check all equipment for cracks, dents, bending, rust, wear, corrosion and other damage. If the equipment was overloaded, or if you notice cracks or other signs of overloading and damage promptly remove equipment from use and have it repaired or replaced. **DO NOT CONTINUE TO USE DAMAGED OR OVERLOADED EQUIPMENT OR WIRE ROPE.**
 - Check all fasteners for stripped threads, wear, bends, and other damage.
 - Check the gearbox for signs of leakage. Contact the factory if there are any signs of lubricant leaking from the gearbox.
 - Make sure the breather plug is clean, open and installed correctly,
 - Remove guards and visually inspect the rotary limit switch chain for poor alignment, excessive wear, corrosion, and other damage.
 - Make sure the entire hoist is properly lubricated.
 - Make sure all labels and plates are readable, firmly attached, free of damage and clean. Replacements are available from the factory.
- b DRAIN A SMALL AMOUNT OF LUBRICANT from the reducer into a clean container. Maintenance free reducers do not require this.
 - Check the lubricant for dirt, metal particles, water, and other signs of contamination. Completely drain the reducer if lubricant is contaminated.
- c INSPECT THE WIRE ROPE according to the wire rope manufacturer's recommendations or follow accepted industry standards for wire rope inspections.
 - Always wear protective clothing when handling wire rope.
 - Check the entire length of wire rope for bent wires, crushed areas, broken or cut wires, corrosion, and other damage. Carefully inspect areas that pass over sheaves or through roller guides.
 - Note the location and concentration of broken wires. Replace wire rope if more than 6 wires are broken in one lay, or more than 3 wires are broken in one strand in one lay. See Figure 8.
 - Make sure the end fittings are securely attached to the wire rope, and the wire rope where it is attached is not frayed, corroded, broken, or otherwise damaged.
 - Check the anchor holes in the drum and the surrounding area for signs of wear or distortion.
- d PLACE enough weight to keep the wire rope straight and tightly drawn.
 - Measure the diameter of the wire rope, especially in areas where wear is noticeable. Replace the wire rope if the diameter measures below the minimum diameter at any point. See Figure 9.
- e MOVE THE DRUM with your hands.
 - Check for excessive movement indicating worn or loose gears or bearings. Excessive movement is caused by overloading or overheating, and is a sign that your application may require a larger power hoist.

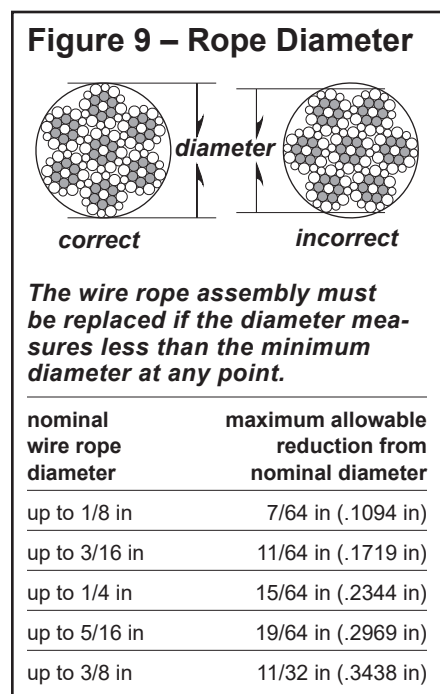

- Disassemble the hoist if necessary. Inspect keys, bearings, seals, and shafts for wear, distortion, and other damage.
- f INSPECT AND TEST RELEASE SYSTEM
- Check to make sure the wire rope lays correctly as the load is transferred from the lift lines back to the dead hung chains.
- g INSPECT THE FOUNDATION AND RIGGING
- Check mounting fasteners for stripped threads, wear, and other damage.
 - Check the foundation for cracks, corrosion, and other damage.
- h TEST HOIST PERFORMANCE by operating the hoist with a load not exceeding the load rating.
- Listen for unusual noises, and look for signs of damage as you operate the hoist.
 - Make sure the wire rope winds evenly and tightly onto the drum. If it is loose or uneven, rewind it before continuing.
 - Observe the rotating drum, look for signs of loose or misaligned bearings.
 - Make sure the load moves smoothly without hesitation or strain.
 - Make sure the hoist responds to the control device. It must rotate as shown on the control labels, and it must turn off when you release the control.
 - Check the motor brake. Raise the load, then lower it and stop it a few feet off the ground. If the load continues to coast or creep, the brake needs adjustment. Refer to brake manufacturer's instructions.
- i DISCONNECT ELECTRIC POWER and inspect electrical equipment.
- Check electrical wires for worn insulation, cuts, corroded connections, and other damage.
 - Check voltage of electrical supply with a UL approved voltmeter. If voltage is low, have a licensed electrician inspect the circuit.
 - Make sure the electrical control box is securely installed. Look inside the control box for signs of moisture, corrosion, burn marks, cracks, and other damage.
- j CONNECT ELECTRIC POWER.

Completely correct all problems before continuing. Use the troubleshooting chart to help determine the cause of certain problems. See Table 2.

Table 1 – Inspection Checklist

checked boxes indicate damage or problem in need of repair

	damages	problems
general	<input type="checkbox"/> finish weathered, flaking, otherwise damaged <input type="checkbox"/> parts cracked, bent, rusted, worn, otherwise damaged	<input type="checkbox"/> hoist jerks or hesitates during operation <input type="checkbox"/> unusual noises, other signs of malfunction
fasteners	<input type="checkbox"/> stripped threads, bent, worn, otherwise damaged	<input type="checkbox"/> loose, not tightened to proper torque
reducer	<input type="checkbox"/> gears, bearings, or shafts loose, worn, otherwise damaged <input type="checkbox"/> lubricant leakage	<input type="checkbox"/> not properly lubricated <input type="checkbox"/> lubricant contaminated
wire rope	<input type="checkbox"/> bent, crushed, otherwise damaged <input type="checkbox"/> broken wires, see Figure 8 replace if more than 6 wires in one lay, or 3 wires in one strand in one lay, are broken <input type="checkbox"/> diameter reduced, see Figure 9	<input type="checkbox"/> wire rope loosely or unevenly wound number per strand = number per lay = diameter =
end connections	<input type="checkbox"/> corroded, rusted, worn, otherwise damaged	<input type="checkbox"/> not securely attached
drum	<input type="checkbox"/> anchor hole worn, distorted, otherwise damaged	<input type="checkbox"/> excessive movement or backlash
motor	<input type="checkbox"/> motor burnt out, otherwise damaged	<input type="checkbox"/> voltage at motor low
brake	<input type="checkbox"/> brake worn, broken, otherwise damaged	<input type="checkbox"/> brake does not operate properly
rotary limit switch	<input type="checkbox"/> chain drive worn, corroded, otherwise damaged	<input type="checkbox"/> poor alignment or loose
control device	<input type="checkbox"/> electric components corroded, burnt, otherwise damaged	<input type="checkbox"/> fails to control hoist properly
electric circuit	<input type="checkbox"/> electric wires worn, cut, corroded, otherwise damaged <input type="checkbox"/> connections loose, corroded, otherwise damaged	<input type="checkbox"/> wires unprotected, obstructing traffic voltage at motor =
labels and plates	<input type="checkbox"/> dirty, illegible, otherwise damaged	<input type="checkbox"/> loosely attached or missing
retarder	<input type="checkbox"/> fluid level low	<input type="checkbox"/> failure to regulate speed
comments	_____ _____ _____ _____ _____ _____ _____ _____ _____ _____	
authorized signature	_____	date _____

Table 2 – Troubleshooting Chart

Contact the factory for assembly/disassembly instructions. Disassembly of the gearbox before contacting Thern, Inc. voids all warranties.

problem	cause	correction
motor won't run	<ul style="list-style-type: none"> • circuit breaker tripped or fuse blown reset circuit breaker or replace fuse • electrical connections loose or damaged inspect, repair and tighten as necessary • electric power supply failure contact power company • motor burnt out or damaged repair or replace as necessary • limit switch struck..... run hoist off limit switch and check adjustments • fire release line not reset..... reset fire release line 	
motor runs, drum doesn't turn	<ul style="list-style-type: none"> • loose or broken gear keys inspect and replace as necessary • loose, stripped or broken gears inspect and replace as necessary 	
motor tries to turn but can't	<ul style="list-style-type: none"> • unit overheated..... allow to cool • load too heavy lighten load • voltage at motor too low inspect supply circuit and rewire as needed • electric brake not operating properly inspect and repair as necessary • gears or bearings broken or locked..... inspect and replace as necessary • loss of phase check phases 	
brake does not operate properly	<ul style="list-style-type: none"> • brake release lever in release position contact a Thern installer • voltage to brake incorrect check voltage at control box, repair as needed • brake adjusted incorrectly adjust brake • brake discs or solenoid worn or damaged..... inspect and replace as necessary • brake components seized up or damaged inspect and repair as necessary • Fire release line not reset..... reset fire release line 	
lubricant leakage	<ul style="list-style-type: none"> • worn bearings inspect and replace as necessary • damaged oil seals or gaskets inspect and replace as necessary • cracked or damaged reducer inspect and repair as necessary 	
excessive end play on drive shaft	<ul style="list-style-type: none"> • loose or damaged keys or keyways inspect and replace as necessary • excessively worn gears inspect and repair as necessary 	
excessive worn gears or bearings	<ul style="list-style-type: none"> • load too heavy lighten load • poor lubrication of reducer or bearings..... inspect and lubricate as necessary 	
overheating	<ul style="list-style-type: none"> • operated too long without rest..... allow to cool • load too heavy lighten load • poor lubrication inspect and lubricate as necessary • breather plug clogged or damaged clean or replace breather plug • bearing seized up inspect and replace as necessary 	
unusual noises		
high pitched squeak	<ul style="list-style-type: none"> • poor lubrication inspect and lubricate as necessary 	
grinding noise	<ul style="list-style-type: none"> • contaminated oil drain, clean and lubricate the hoist • broken gears or bearings inspect and replace as necessary 	
whining motor	<ul style="list-style-type: none"> • load too heavy lighten load • motor overheated allow to cool • motor bearings burnt out replace motor or bearings 	
rattling noise	<ul style="list-style-type: none"> • loose fasteners or setscrews tighten all bolts and screws • worn or loose drag brake..... inspect and repair or tighten as necessary 	
heavy thump during operation	<ul style="list-style-type: none"> • contaminants in lubricant..... drain, clean and lubricate the hoist • loose setscrews or keys in gears or shafts..... inspect and repair as necessary • bearings defective inspect and replace as necessary 	
hoist speed not regulated when fire line is released	<ul style="list-style-type: none"> • flow control valve not adjusted contact a Thern installer • directional control valve set incorrectly..... contact a Thern installer • Fluid level low add fluid 	

3.5 Repairing the Hoist

Important!

- It is your responsibility to determine when to replace parts. When considering whether to continue using a part or to replace it, remember that replacing it is the best way to avoid further equipment damage.
- Replace spring pins, retaining rings, and oil seals whenever the hoist is disassembled for inspection or repair.
- Appoint a qualified person to be responsible for all repairs to the equipment.

- 3.5.1 GET FACTORY AUTHORIZATION for all repairs. Unauthorized repairs will void the warranty, and may lead to damage or failure of the hoist.
- 3.5.2 REPLACE DAMAGED OR POORLY OPERATING PARTS with Thern repair parts.
- 3.5.3 REFINISH AREAS where the paint is worn or flaking. A good finish helps to protect against corrosion and weather damage.
 - a REMOVE THE FINISH from damaged areas, down to the bare metal.
 - b CLEAN THE AREA thoroughly.
 - c REPAINT with a high quality primer and finishing coat.
- 3.5.4 TO ORDER REPAIR PARTS, contact your local dealer. Include the following information when ordering:
 - model number
 - serial number (or code number)
 - part number
 - date purchased, and from whom
 - description of what happened, or what is wrong
 - your name and return address

4.1 Transporting the Hoist

Important!

- Keep a record of what you ship, and when you send it.

- 4.1.1 REMOVE THE BREATHER PLUG and install a sealed plug to prevent the loss of lubrication during shipment.
 - a DRAIN hydraulic reservoir by removing the drain plug and allow all fluid to empty. Replace the drain plug. Sec. 3.4.4a and Figure 2A.
- 4.1.2 PACK THE HOIST in an upright position for transport, using the original packaging materials, if possible.
 - a FASTEN THE HOIST to a wooden base using bolts, to keep it from moving during transport.
 - b SEAL THE HOIST in plastic with a desiccant to help protect it from rust, corrosion, and other damage.
 - c CONSTRUCT WOODEN SIDES and top to enclose the hoist in a solid protective crate.
 - d PACK LOOSE PARTS in small boxes or ship separately.
- 4.1.3 INSPECT THE HOIST according to the Instructions for Periodic Inspection before installing it in a new location.

4.2 Storing the Hoist

- 4.2.1 FILL THE REDUCER with lubricant, and make sure the breather plug is clean and properly installed. Add a rust preventative for long term storage. Follow the reducer manufacturer's instructions.
- 4.2.2 SEAL THE HOIST in plastic with a desiccant to help protect it from rust, corrosion, and other damage.
- 4.2.3 STORE THE HOIST upright, in a cool clean place away from corrosive chemicals and moisture.
- 4.2.4 ROTATE THE DRUM PERIODICALLY to keep bearing and gears surfaces from becoming lacquered. Release the brake to rotate the drum.
- 4.2.5 INSPECT THE HOIST according to the Instructions for Periodic Inspection before installing it for operation.
- 4.2.6 TEST INSULATION RESISTANCE in the motor to detect moisture damage. Refer to the motor manufacturer's instructions.
- 4.2.7 DRAIN THE REDUCER and fill with proper lubricant prior to operation. See section 3.4 Lubricating the Hoist.



**5712 Industrial Park Road
Winona, MN 55987**

**PHN 800-553-2204
FAX 507-454-5282**

**EMAIL: info@thernstage.com
www.thernstage.com**