

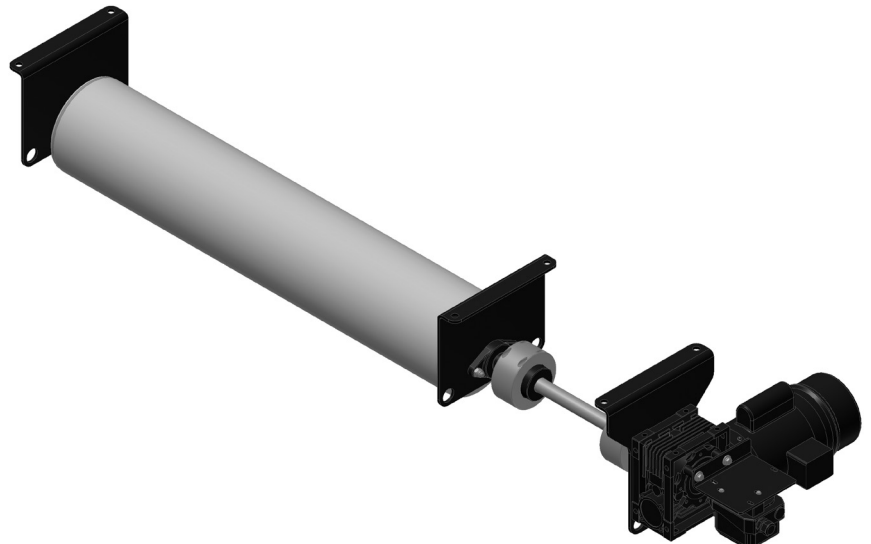

Read this Owner's Manual thoroughly before operating the equipment. Keep it with the equipment at all times. Replacements are available from Thern Stage Equipment, 5712 Industrial Park Rd., Winona, MN 55987, 507-454-2996. [www.thern.com](http://www.thern.com)

**IMPORTANT:** Please record product information on page 2. This information is required when calling the factory for service.



# Owner's Manual

For  
RD Series  
Rolldrops

## Two-Year Limited Warranty

**Please record the following:**

Date Purchased: \_\_\_\_\_

Model No.: \_\_\_\_\_

Serial No.: \_\_\_\_\_

**This information is required when calling the factory for service.**

Thern, Inc. warrants its products against defects in material or workmanship for two years from the date of purchase by the original using buyer, or if this date cannot be established, the date the product was sold by Thern, Inc. to the dealer. To make a claim under this warranty, contact the factory for an RGA number. The product must be returned, prepaid, directly to Thern, Inc., 5712 Industrial Park Road, Winona, Minnesota 55987. The following information must accompany the product: the RGA number, the date of purchase, the description of the claimed defect, and a complete explanation of the circumstances involved. If the product is found to be defective, it will be repaired or replaced free of charge, and Thern, Inc. will reimburse the shipping cost within the contiguous USA.

This warranty does not cover any damage due to accident, misuse, abuse, or negligence. Any alteration, repair or modification of the product outside the Thern, Inc. factory shall void this warranty. This warranty does not cover any costs for removal of our product, downtime, or any other incidental or consequential costs or damages resulting from the claimed defects. This warranty does not cover brake discs, wire rope or other wear components, as their life is subject to use conditions which vary between applications.

FACTORY AUTHORIZED REPAIR OR REPLACEMENT AS PROVIDED UNDER THIS WARRANTY IS THE EXCLUSIVE REMEDY TO THE CONSUMER. THERN, INC. SHALL NOT BE LIABLE FOR ANY INCIDENTAL OR CONSEQUENTIAL DAMAGES FOR BREACH OF ANY EXPRESS OR IMPLIED WARRANTY ON THIS PRODUCT. EXCEPT TO THE EXTENT PROHIBITED BY APPLICABLE LAW, ANY IMPLIED WARRANTY OF MERCHANTABILITY OR FITNESS FOR A PARTICULAR PURPOSE ON THIS PRODUCT IS LIMITED IN DURATION TO THE DURATION OF THIS WARRANTY.

Some states do not allow the exclusion or limitation of incidental or consequential damages, or allow limitations on how long an implied warranty lasts, so the above limitation or exclusion may not apply to you. This warranty gives you specific legal rights, and you may also have other rights which vary from state to state.

**Note: Thern, Inc. reserves the right to change the design or discontinue the production of any product without prior notice.**

## About This Manual

The Occupational Safety and Health Act of 1970 states that it is the employer's responsibility to provide a workplace free of hazard. To this end, all equipment should be installed, operated, and maintained in compliance with applicable trade, industrial, federal, state, and local regulations. It is the equipment owner's responsibility to obtain copies of these regulations and to determine the suitability of the equipment to its intended use.

This Owner's Manual, and warning labels attached to the equipment, are to serve as guidelines for hazard-free installation, operation, and maintenance. They should not be understood to prepare you for every possible situation.

Information contained in this Owner's Manual is applicable only to Thern RD Series Rolldrops. Do not use this manual as a source of information for any other equipment.

**The following symbols are used for emphasis throughout this manual:**

**⚠WARNING**

Failure to follow 'WARNING!' instructions may result in equipment damage, property damage, and/or serious personal injury.

**⚠CAUTION**

Failure to follow 'CAUTION!' instructions may result in equipment damage, property damage, and/or minor personal injury.

**Important!**

Failure to follow 'Important!' instructions may result in poor performance of the equipment.

## Suggestions for Safe Operation

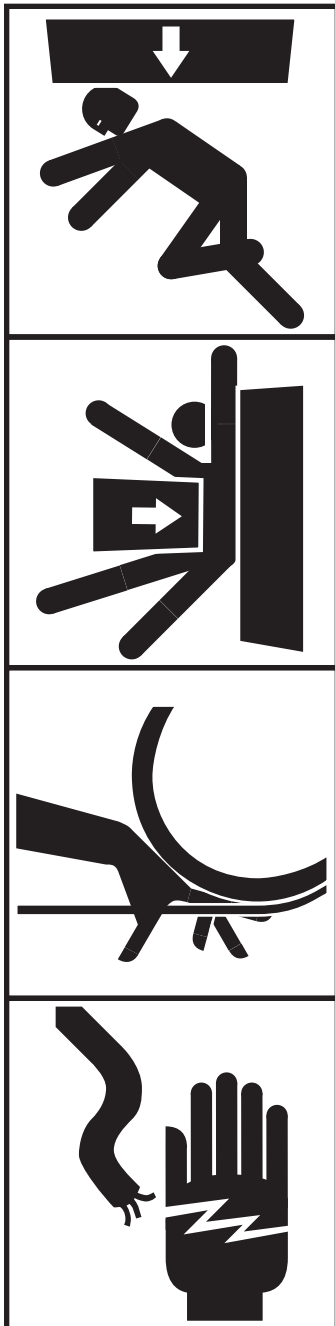

### **⚠️WARNING**

#### **DO the following:**

Read and comply with the guidelines set forth in this Owner's Manual. Keep this manual, and all labels attached to the rolldrop, readable and with the equipment at all times. Contact Thern, Inc. for replacements.

Check lubrication before use.

Install the load material securely to the rolldrop drum.

Keep at least 4 wraps of load material wound on the drum at all times, to serve as anchor wraps. With less than 4 wraps on the drum the load material could come loose, causing the load to escape.

Keep hands away from the drum, gears, drive shaft, and other moving parts of the equipment.

Keep all unnecessary personnel away from rolldrop while in operation. Keep out of the path of the load.

Disconnect electric power before servicing the equipment.

#### **DO NOT do the following:**

This product designed for lifting and moving material only. Do not use this product for any other purpose.

Do not exceed the load rating of the rolldrop or any other component in the system. To do so could result in failure of the equipment.

Do not use damaged or malfunctioning equipment. To do so could result in failure of the equipment.

Do not modify the equipment in any way. To do so could cause equipment failure.

Do not operate the rolldrop with drive guards or gear covers removed or improperly installed.

Do not divert your attention from the operation. Stay alert to the possibility of accidents, and try to prevent them from happening.

Do not jerk or swing the load. Avoid shock loads by starting and stopping the load smoothly. Shock loads overload the equipment and may cause damage.

Do not adjust the brake with the rolldrop holding a load. Accidental release of the brake could result in loss of the load.

## 1.1 Installing the Rolldrop

### Important!

- Inspect the rolldrop immediately following installation according to the Instructions for Periodic Inspection. This will give you a record of the condition of the rolldrop with which to compare future inspections.
- A qualified professional should inspect or design the foundation to insure that it will provide adequate support.
- Locate the rolldrop so it will be visible during the entire operation.
- When positioning the rolldrop use the lifting holes provided or a sling wrapped around drum and reducer assembly.
- Do not attempt to lift or position rolldrop by using lifting hole on reducer. This hole is designed to lift the reducer only.
- Do not weld the rolldrop frame to the foundation or support structure. Welding the frame may void warranty, contact Thern, Inc. Use fasteners as instructed.

**Figure 1 – Drive Shaft Coupling Spacing**

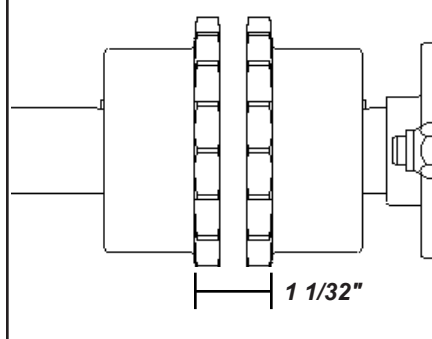

### ⚠WARNING

**Do not install the rolldrop in an area defined as hazardous by the National Electric Code, unless installation in such an area has been thoroughly approved.**

**Do not install the rolldrop near corrosive chemicals, flammable materials, explosives, or other elements that may damage the rolldrop or injure the operator. Adequately protect the rolldrop and the operator from such elements.**

**Position the rolldrop so the operator can stand clear of the load.**

**Attach the rolldrop to a rigid and level foundation that will support the rolldrop and its load under all load conditions, including shock loading.**

- 1.1.1 CONSULT APPLICABLE CODES AND REGULATIONS for specific rules on installing the equipment.
- 1.1.2 LOCATE THE ROLLDROP in an area clear of traffic and other obstacles. Make sure the rolldrop is accessible for maintenance and operation.
- 1.1.3 LOCATE THE ROLLDROP in an area with adequate temperatures. Check the motor and reducer manufacturer's information for ambient temperature ratings.
- 1.1.4 POSITION THE ROLLDROP to allow access for proper lubrication.
- 1.1.5 INSTALL THE ROLLDROP on a horizontal surface. The rolldrop is designed and assembled for upright, underhung or wall mount installation.
- 1.1.6 FASTEN THE ROLLDROP SECURELY to the foundation.
  - a For Standard products referred to in this manual, use coarse thread fasteners, grade 5 or better. Be sure to check the torque required for your fastener selection before mounting rolldrop. Make sure the rolldrop is secured to a solid foundation able to support the rolldrop and the load under all conditions with design factors based on accepted engineering practices.
  - b Non-standard products that vary from the original design may have different fastening requirements. Contact a structural engineer or Thern, Inc. for this information.
  - c ATTACH DRUM with bearing end plates securely in place.
  - d ATTACH MOTOR/REDUCER section securely in place.
- 1.1.7 INSTALL COUPLING SPROCKETS on shafts. If flanges are bushed type, install per instructions packed with bushings. Space flanges the proper distance apart for proper fit. Shaft ends must not project beyond the flanges. See Figure 1.
- 1.1.8 ALIGN SHAFTS. Some parallel and angular misalignment usually develops in usage. Therefore, the shaft must be aligned as accurately as possible during installation to minimize wear. This will result in longer service life with lower maintenance.
- 1.1.9 WRAP CHAIN around flanges and secure ends. Chain should move freely on flanges when coupling is properly aligned. Install coupling cover.

CONTACT A QUALIFIED PROFESSIONAL FOR MOUNTING INSTRUCTIONS TO COMPLY WITH LOCAL CODES.

---

## 1.2 Installing the Breather Plug

(on reducers requiring breather plug)

**Important!**

- Save the sealed plug for use when the rolldrop is removed for storage or transport.

**⚠ CAUTION**

**Install the breather plug to vent heat and pressure. Failure to do so could result in pressure buildup which could damage the reducer.**

**Motovario reducers are maintenance free and do not require a breather.**

For shipment, the reducer is filled with lubricant and sealed to prevent lubrication loss.

SEW Eurodrive reducers are supplied with the breather plug installed. Before operation the black rubber seal located on the breather plug **MUST BE REMOVED**. Refer to the reducer manufacturer's instructions for additional information or for information on other reducer types.

Some units supplied may not have a breather plug installed for shipment. Install the breather plug before operation.

- 1.2.1 REMOVE THE SEALED PLUG from the breather plug hole.
- 1.2.2 CHECK THE LUBRICANT LEVEL in the reducer to make sure no lubricant was lost during shipment. Refer to the reducer manufacturer's instructions.
- 1.2.3 INSTALL THE BREATHER PLUG. The breather plug is wired to the reducer or attached in a plastic bag. Refer to the reducer manufacturer's information.

## 1.3 Connecting Electric Power

### Important!

- Use electrical equipment with the correct rating and Underwriter's Laboratory (UL) approval.
- Always disconnect electric current when the rolldrop is not in use.

### **⚠WARNING**

**Install proper branch circuits, disconnect devices, protection, and grounding as required by article 430 of the National Electric Code.**

**All electrical work must be performed by a licensed electrician. Failure to do so could result in electric shock or poor rolldrop operation.**

**All control devices must be momentary contact type. Install all control devices so the rolldrop motor will stop when the operator releases the device.**

**Locate control devices so the operator will be able to view the load through the entire operation.**

**Locate control devices so the operator will be clear of the load.**

It is the responsibility of the owner to provide equipment for controlling the rolldrop. Electrical control packages are available from Thern. The following guidelines are supplied as a reference for the installer.

- 1.3.1 CONSULT APPLICABLE CODES AND REGULATIONS for specific rules on electrical installation.
- 1.3.2 CHECK THE COMPONENT MANUFACTURER'S INSTRUCTIONS for installing and connecting the motor, brake, and other equipment.
- 1.3.3 INSTALL A FUSE or circuit breaker in the power supply circuit, as required by the National Electric Code.
- 1.3.4 INSTALL A DISCONNECT DEVICE in the power supply circuit, as required by the National Electric Code. This should be a switch you can lock in the OFF position to prevent unauthorized use of the rolldrop.
- 1.3.5 CONNECT ELECTRIC STARTER CONTROLS to the motor. **Make sure the load brake is wired for fast braking on brakemotors that offer this function.** Check the component manufacturer's information.
- 1.3.6 CONNECT ELECTRIC POWER SUPPLY, with ground wire, to the electric starter control box. Check the component manufacturer's information for a wiring diagram.
- 1.3.7 CONNECT OTHER ELECTRIC EQUIPMENT to the proper terminals in the electric control box.
- 1.3.8 CHECK THE CURRENT at the motor and make sure it agrees with the current rating marked on the rolldrop nameplate. If current rating is incorrect, have the circuit inspected by a licensed electrician.
- 1.3.9 TEST ELECTRICAL CONNECTIONS, when provided, by operating the rolldrop.
  - a ROTATION OF THE DRUM must agree with the labels on the control device, either UP and DOWN, or FORWARD and REVERSE.
  - b CHECK THE LOAD BRAKE, make sure it releases when the motor is ON, and engages when the motor is OFF. **Make sure the fast brake function operates correctly on brakemotors that include this feature.**

CONTACT THE FACTORY OR A QUALIFIED PROFESSIONAL FOR HELP.

---

## 1.4 Installing the Load Material

**Important!**

- Excess load or drum deflection may cause uneven winding.

**⚠WARNING**

**Install the load material securely to the rolldrop drum. Poorly secured load material could come loose and allow the load to escape.**

- 1.4.1 **ATTACH MATERIAL** to the rolldrop using tabs of tape or other appropriate adhesive material. Make sure the attachment is in one straight, direct line. Then use a solid stretch of tape to hold the material securely in place.
- 1.4.2 **ROLL THE MATERIAL** onto the drum a minimum of 4 wraps to serve as anchor wraps. With less than 4 wraps on the drum, the material could come loose causing the material to escape.
- 1.4.3 **TESTING IS RECOMMENDED** to ensure material is rolling on evenly. Roll the material on completely.
- 1.4.4 **IF ADJUSTMENTS ARE REQUIRED**, repeat steps 1-3.

## 1.5 Setting Travel Limits

### ⚠ CAUTION

Limit set points are dependant on speed of operation. Use caution with setting limits on units with variable speed operation. Typically, limits should be for the highest speed to be encountered.

Correct setup may take some trials and adjustments.

Standard units are shipped with TER limit switches. For units equipped with other limit switches, refer to manufacturer's instructions.

Each unit's travel is controlled by two sets of limit switches driven from the gear box output shaft. One set controls the normal movement (travel limit) of the unit. The other set (overtravel limit) are there to indicate an overtravel in the event of a failure to the travel limits.

The overtravel limits should be set first to determine the absolute maximum range of travel that the unit is able to run securely. The travel limits should be set within this range to limit the movement of the normal operating range.

- 1.5.1 SET LIMITS by doing the following. **Overtravel limits should be set before travel limits. Refer to manufacturer's instructions. See Figure 2.**
- a REMOVE the limit switch cover.
  - b LOOSEN the large locking screw in the center of the column. Individual limits can now be set.
  - c DETERMINE WHICH DIRECTION the limit switch cam rotates when the "UP" button is pressed.
  - d TURN THE SCREW labeled "1" so that the microswitch is hit by the cam when the load "opens" to the desired position. The lower limit "4" should be adjusted so that the microswitch is hit by the cam as the unit moves into position in the "DOWN" direction.
  - e REPEAT THE PROCESS with screws labeled "2" and "3" to set the normal operating travel limits.
  - f AFTER SETTING ALL LIMITS the locking screw can be tightened and the limits re-checked.
  - g REPLACE the cover.

**Figure 2 – Setting Travel Limits**

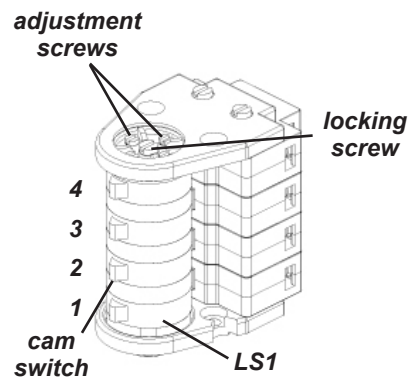

Switch	Position	Travel
LS1	Up	Over
LS2	Up	Normal
LS3	Down	Normal
LS4	Down	Over

---

## 2.1 General Theory of Operation

**Important!**

- To help insure rated performance, make sure voltage at the motor is equal to the motor's voltage rating.
- It is your responsibility to detect and account for different factors affecting the condition and performance of the equipment.

- 2.1.1 THE FORCE REQUIRED to move the load must not exceed the load rating of the rolldrop. Consider the total force required to move the load, not just the weight of the load.
- 2.1.2 THIS EQUIPMENT CAN develop forces that will exceed the load rating. It is the responsibility of the equipment user to limit the size of the load. Inspect the equipment regularly for damage according to the instructions contained in this manual and in the component manufacturer's information.
- 2.1.3 USE A LOAD BRAKE on all equipment used to lift loads or drag loads on an incline. Although a new worm gear rolldrop may appear to hold the load in place, this characteristic will diminish with use. **Do not depend on rolldrop gearing to hold the load in place.**
- 2.1.4 PERFORMANCE RATINGS of the equipment are affected by the amount of load material wound on the drum, the way in which it is wound, and the way the rolldrop is used.
- a LINE SPEED is the speed that the load will travel. The weight of the load does not affect line speed.
  - b LOAD RATING represents the maximum load that can be placed on new equipment. Load ratings are assigned values for specific amounts of load or drum length. The load rating decreases with longer drum lengths.
- 2.1.5 DUTY RATINGS refer to the type of use the equipment is subject to. Consider the following when determining duty rating.
- a ENVIRONMENT: harsh environments include hot, cold, dirty, wet, corrosive, or explosive surroundings. **Protect the equipment from harsh environments when possible.**
  - b MAINTENANCE: poor maintenance, meaning poor cleaning, lubrication, or inspection, leads to poor operation and possible damage of the equipment. **Minimize poor maintenance by carefully following the instructions contained in this manual.**
  - c LOADING: severe loading includes shock loading and moving loads that exceed the load rating of the equipment. **Avoid shock loads, and do not exceed the load rating of the equipment.**
  - d FREQUENCY OF OPERATION: frequent start and stop functions increase wear and shorten the life span of the gear train and load brake components. Lengthy operations cause lubrication to become hot, which also decreases the life span of the gear train. **Increase maintenance of the equipment if used in frequent operations.**

CONTACT THE FACTORY FOR MORE INFORMATION.

---

## 2.2 Breaking-In the Rolldrop

- 2.2.1 BREAK-IN OCCURS during the first few hours of normal operation. During break-in, mating surfaces become polished, and clearances increase. This is desired for efficient operation of bearings and gears.
- 2.2.2 INSPECT THE ROLLDROP following break-in according to the Instructions for Periodic Inspection. See section 3.3 Inspecting the Equipment.

---

## 2.3 Preparing for Operation

### Important!

- When determining whether the load will exceed the load rating, consider the total force required to move the load.

- 2.3.1 CONSIDER THE OPERATION. Do not begin until you are sure you can perform the entire operation without hazard.
- 2.3.2 BEFORE INITIAL OPERATION inspect the hoist and all components of the system according to Instruction for Frequent Inspection.
- 2.3.3 BEFORE EACH OPERATION inspect all components of the system.
- a OPERATORS must be in good health, alert, thoroughly trained in operating the equipment, and properly clothed (safety equipment as required, no loose clothing, no loose jewelry).
  - b THE LOAD must be clear of other objects and free to move. Make sure the load will not tip, bind, or in any way move uncontrollably.
- 2.3.4 KNOW YOUR LOAD and make sure you do not exceed the load rating of the hoist or any other equipment in the system.

---

## 2.4 Moving the Load

### Important!

- Obey a stop signal from anyone.
- Maintain tension on the load material to keep it tightly and evenly wound on the drum.
- If the rolldrop and load are not visible during the entire operation, get help from another person.
- Appoint a supervisor if more than one person is involved in the operation. This will reduce confusion and increase safety.

- 2.4.1 MOVE THE LOAD slowly and smoothly, only a small distance at first. Make sure the load is balanced and securely attached before continuing.
- 2.4.2 USE THE CONTROL DEVICE to operate the rolldrop. The control device should be momentary contact type, so the rolldrop will stop when the operator releases the control.
- 2.4.3 OBSERVE THE LOAD MATERIAL as it winds onto the drum. If it becomes loose, uneven, or overlapped, stop the operation and rewind the load material before continuing. **Continued operation with uneven load material can damage the load material and shorten its life.**
- 2.4.4 OBSERVE THE REDUCER during operation for signs of overheating. **Frequent overheating may be a sign of damage, or may indicate the need for a larger power rolldrop.**
- a WATCH FOR SMOKE, the smell of burnt lubricant, and other signs of overheating. Use a thermocouple or other device to monitor reducer temperature.
  - b STOP THE OPERATION if the reducer overheats, and allow the rolldrop to cool. **Continued operation may cause damage.**

**Important!**

Increase the frequency of maintenance procedures if the rolldrop is:

- Operated for long periods.
- Used to lift heavy loads.
- Operated in wet, dirty, hot, or cold surroundings.

---

### 3.1 Cleaning the Rolldrop

Clean the rolldrop to remove dirt and help prevent rust and corrosion.

- 3.1.1 CLEAN THE ROLLDROP every six months or whenever it is dirty.
  - a WIPE ALL EQUIPMENT to remove dirt and grease.
  - b LEAVE A LIGHT FILM of oil on all surfaces other than the drum to protect them against rust and corrosion.
  - c WIPE OFF excessive amounts of oil to avoid the accumulation of dirt.
- 3.1.2 REMOVE ALL UNNECESSARY OBJECTS from the area around the rolldrop.

---

### 3.2 Adjusting the Brakes

**⚠WARNING**

**Do not adjust the brake with the load suspended. Accidental release of the brake could allow the load to escape.**

**Important!**

- Do not overtighten the brake, since this will cause parts to wear and become damaged.

- 3.2.1 CHECK THE BRAKES by operating the rolldrop with a load equal to the rolldrop load rating.
  - a RAISE THE LOAD, then lower it and stop it about one foot off the ground.
  - b OBSERVE THE LOAD when stopped.
  - c REFER TO BRAKE manufacturer's instructions.

### 3.3 Lubricating the Rolldrop

#### Important!

- Do not leave plug holes in the reducer open. Open plug holes will allow dirt and moisture to contaminate the lubrication.
- Make sure lubricant has a temperature rating appropriate for the ambient temperatures of the operation.
- Replace the motor bearings if the motor is disassembled for any reason.

**Figure 3 – Lubricating the Flange Bearing**

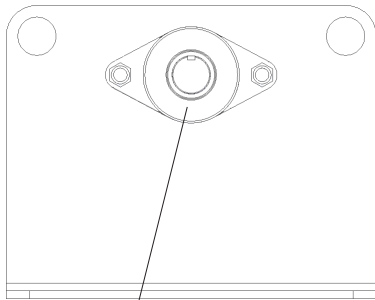

*flange bearing,  
lubricate with NLGI  
no. 2EP grease*

#### ⚠ CAUTION

**Make sure the breather plug is clean and open to vent heat and pressure. Poor ventilation may cause overheating and result in damage to oil seals and other equipment.**

**Fill the speed reducer to the proper level without overfilling. Too much or too little lubricant will cause overheating and result in damage to seals, bearings, and gears.**

**Motovario reducer's are maintenance free. They do not contain breathers or require additional lubrication.**

Lubricate the rolldrop properly to help protect it from wear and rust. Read the following instructions carefully.

- 3.3.1 MOTOR BEARINGS are typically lubricated for life by the manufacturer. Some motors require periodic lubrication. Refer to the motor manufacturer's information for specific instructions.
- 3.3.2 LUBRICATE THE REDUCER according to the manufacturer's instructions.
  - a CHECK OIL LEVEL monthly. Remove the level plug and make sure oil is even with the plug hole.
  - b FILL THE REDUCER according to the manufacturer's instructions. Fill the reducer until oil reaches the level plug. **Do not mix different lubricants.**
  - c CHANGE REDUCER LUBRICANT at least every 12 months, or whenever it is dirty or contaminated.
- 3.3.3 LUBRICATE FLANGE BEARING monthly. Insert NLGI #2 EP (Extreme Pressure) grease through the grease zerk. Refer to the bearing manufacturer's information for specific instructions. See Figure 3.
- 3.3.4 LUBRICATE THE CHAIN COUPLING according to the manufacturer's instructions.

## 3.4 Inspecting the Equipment

### Important!

- Start an inspection program as soon as you put the rolldrop into use.
- Appoint a qualified person to be responsible for regularly inspecting the equipment.
- Keep written records of inspection. This allows comparison with comments from previous inspections so you can see changes in condition or performance.

### Perform frequent inspections:

- Before initial operation.
- Monthly during operation.
- Whenever you notice signs of damage or poor operation.

### **⚠WARNING**

**Do not use damaged or malfunctioning equipment. Place an “OUT OF ORDER” sign on the equipment. Do not use the equipment until the sign is removed by a qualified maintenance person who has completely corrected the problem.**

Inspect the rolldrop to detect signs of damage or poor operation before they become hazardous. See Table 1 - Inspection Checklist.

3.4.1 CONSULT APPLICABLE CODES AND REGULATIONS for specific rules on inspecting the rolldrop and other equipment.

3.4.2 CHECK COMPONENT MANUFACTURER'S INSTRUCTIONS for inspecting the motor, brake, reducer, bearings, couplings, and other equipment.

### 3.4.3 Instructions for Frequent Inspection

- a VISUALLY INSPECT the entire rolldrop and all other equipment involved in the operation.
  - Check all equipment for cracks, dents, bending, rust, wear, corrosion and other damage.
  - Make sure the load material is installed correctly and anchored securely to the drum.
  - Check the reducer for signs of leakage.
  - Make sure the entire rolldrop is properly lubricated.
  - Make sure the breather plug is clean, open, and installed correctly.
  - Make sure mounting fasteners are tightened securely.
  - Make sure the foundation is in good condition, and capable of supporting the rolldrop and its load under all load conditions.
  - Check electrical wiring and connections for wear, corrosion, cuts, and other damage.
- b TEST ROLLDROP PERFORMANCE by operating the rolldrop with a load not exceeding the load rating.
  - Listen for unusual noises, and look for signs of damage as you operate the rolldrop.
  - Make sure the load material winds evenly and tightly onto the drum. If it is loose or uneven, rewind it before continuing.
  - Make sure the load moves smoothly, without hesitation or strain.
  - Make sure the rolldrop responds to the control device. It must rotate as shown on the control labels, and it must turn off when you release the control.
  - Check the brake. Raise the load, then lower it and stop it a few feet off the ground. If the load continues to coast or creep, the brake needs adjustment. Refer to brake manufacturer's instructions.

**Completely correct all problems before continuing operation. Use the Troubleshooting Chart to help determine the cause of certain problems. See Table 2.**

**Perform periodic inspections:**

- Every 12 months.
- Whenever you return the rolldrop from storage.
- Whenever you notice damage or poor operation in a frequent inspection.
- Whenever you have, or think you have, overloaded or shock loaded the rolldrop.

**3.4.4 Instructions for Periodic Inspection**

- a VISUALLY INSPECT the rolldrop and all other equipment.
- Check the finish for wear, flaking, or other damage.
  - Check all equipment for cracks, dents, bending, rust, wear, corrosion and other damage. If the equipment was overloaded, or if you notice cracks or other signs of overloading and damage promptly remove equipment from use and have it repaired or replaced. **DO NOT CONTINUE TO USE DAMAGED OR OVERLOADED EQUIPMENT OR LOAD MATERIAL.**
  - Check all fasteners for stripped threads, wear, bends, and other damage.
  - Check the gearbox for signs of leakage. Contact the factory if there are any signs of lubricant leaking from the gearbox.
  - Make sure the breather plug is clean, open and installed correctly,
  - Make sure the entire rolldrop is properly lubricated.
  - Make sure all labels and plates are readable, firmly attached, free of damage and clean. Replacements are available from the factory.
- b DRAIN A SMALL AMOUNT OF LUBRICANT from the reducer into a clean container. Maintenance free reducers do not require this.
- Check the lubricant for dirt, metal particles, water, and other signs of contamination. Completely drain the reducer if lubricant is contaminated.
- c MOVE THE DRUM with your hands.
- Check for excessive movement indicating worn or loose gears or bearings. Excessive movement is caused by overloading or overheating, and is a sign that your application may require a larger power rolldrop.
  - Disassemble the rolldrop if necessary. Inspect keys, bearings, seals, and shafts for wear, distortion, and other damage.
- d INSPECT THE FOUNDATION AND RIGGING
- Check mounting fasteners for stripped threads, wear, and other damage.
  - Check the foundation for cracks, corrosion, and other damage.
- e TEST ROLLDROP PERFORMANCE by operating the rolldrop with a load not exceeding the load rating.
- Listen for unusual noises, and look for signs of damage as you operate the rolldrop.
  - Make sure the load material winds evenly and tightly onto the drum. If it is loose or uneven, rewind it before continuing.
  - Observe the rotating drum, look for signs of loose or misaligned bearings.
  - Make sure the load moves smoothly without hesitation or strain.
  - Make sure the rolldrop responds to the control device. It must rotate as shown on the control labels, and it must turn off when you release the control.

- Check the brake. Raise the load, then lower it and stop it a few feet off the ground. If the load continues to coast or creep, the brake needs adjustment. Refer to brake manufacturer's instructions.
- f DISCONNECT ELECTRIC POWER and inspect electrical equipment.
- Check electrical wires for worn insulation, cuts, corroded connections, and other damage.
  - Check voltage of electrical supply with a UL approved voltmeter. If voltage is low, have a licensed electrician inspect the circuit.
  - Make sure the electrical control box is securely installed. Look inside the control box for signs of moisture, corrosion, burn marks, cracks, and other damage.
- g CONNECT ELECTRIC POWER.

**Completely correct all problems before continuing. Use the troubleshooting chart to help determine the cause of certain problems. See Table 2.**



### Table 2 – Troubleshooting Chart

Contact the factory for assembly/disassembly instructions. Disassembly of the gearbox before contacting Thern, Inc. voids all warranties.

problem	cause	correction
<b>motor won't run</b>	<ul style="list-style-type: none"> <li>• circuit breaker tripped or fuse blown .....</li> <li>• electrical connections loose or damaged .....</li> <li>• electric power supply failure .....</li> <li>• motor burnt out or damaged .....</li> </ul>	<ul style="list-style-type: none"> <li>reset circuit breaker or replace fuse</li> <li>inspect, repair and tighten as necessary</li> <li>contact power company</li> <li>repair or replace as necessary</li> </ul>
<b>motor runs, drum doesn't turn</b>	<ul style="list-style-type: none"> <li>• loose or broken gear keys .....</li> <li>• loose, stripped or broken gears .....</li> </ul>	<ul style="list-style-type: none"> <li>inspect and replace as necessary</li> <li>inspect and replace as necessary</li> </ul>
<b>motor tries to turn but can't</b>	<ul style="list-style-type: none"> <li>• unit overheated.....</li> <li>• load too heavy .....</li> <li>• voltage at motor too low .....</li> <li>• electric brake not operating properly .....</li> <li>• gears or bearings broken or locked.....</li> </ul>	<ul style="list-style-type: none"> <li>allow to cool</li> <li>lighten load</li> <li>inspect supply circuit and rewire as needed</li> <li>inspect and repair as necessary</li> <li>inspect and replace as necessary</li> </ul>
<b>brake does not operate properly</b>	<ul style="list-style-type: none"> <li>• brake release lever in release position.....</li> <li>• voltage to brake incorrect.....</li> <li>• brake adjusted incorrectly .....</li> <li>• brake discs or solenoid worn or damaged.....</li> <li>• brake components seized up or damaged .....</li> </ul>	<ul style="list-style-type: none"> <li>move to lock position</li> <li>check voltage at control box, repair as needed</li> <li>adjust brake</li> <li>inspect and replace as necessary</li> <li>inspect and repair as necessary</li> </ul>
<b>lubricant leakage</b>	<ul style="list-style-type: none"> <li>• worn bearings.....</li> <li>• damaged oil seals or gaskets .....</li> <li>• cracked or damaged reducer .....</li> </ul>	<ul style="list-style-type: none"> <li>inspect and replace as necessary</li> <li>inspect and replace as necessary</li> <li>inspect and repair as necessary</li> </ul>
<b>excessive end play on drive shaft</b>	<ul style="list-style-type: none"> <li>• loose or damaged keys or keyways .....</li> <li>• excessively worn gears .....</li> </ul>	<ul style="list-style-type: none"> <li>inspect and replace as necessary</li> <li>inspect and repair as necessary</li> </ul>
<b>excessive worn gears or bearings</b>	<ul style="list-style-type: none"> <li>• load too heavy .....</li> <li>• poor lubrication of reducer or bearings.....</li> </ul>	<ul style="list-style-type: none"> <li>lighten load</li> <li>inspect and lubricate as necessary</li> </ul>
<b>overheating</b>	<ul style="list-style-type: none"> <li>• operated too long without rest.....</li> <li>• load too heavy .....</li> <li>• poor lubrication.....</li> <li>• breather plug clogged or damaged .....</li> <li>• bearing seized up .....</li> </ul>	<ul style="list-style-type: none"> <li>allow to cool</li> <li>lighten load</li> <li>inspect and lubricate as necessary</li> <li>clean or replace breather plug</li> <li>inspect and replace as necessary</li> </ul>
<b>unusual noises</b>		
high pitched squeak	<ul style="list-style-type: none"> <li>• poor lubrication.....</li> </ul>	<ul style="list-style-type: none"> <li>inspect and lubricate as necessary</li> </ul>
grinding noise	<ul style="list-style-type: none"> <li>• contaminated oil .....</li> <li>• broken gears or bearings .....</li> </ul>	<ul style="list-style-type: none"> <li>drain, clean and lubricate the rolldrop</li> <li>inspect and replace as necessary</li> </ul>
whining motor	<ul style="list-style-type: none"> <li>• load too heavy .....</li> <li>• motor overheated .....</li> <li>• motor bearings burnt out .....</li> </ul>	<ul style="list-style-type: none"> <li>lighten load</li> <li>allow to cool</li> <li>replace motor or bearings</li> </ul>
rattling noise	<ul style="list-style-type: none"> <li>• loose fasteners or setscrews.....</li> <li>• worn or loose drag brake.....</li> </ul>	<ul style="list-style-type: none"> <li>tighten all bolts and screws</li> <li>inspect and repair or tighten as necessary</li> </ul>
heavy thump during operation	<ul style="list-style-type: none"> <li>• contaminants in lubricant.....</li> <li>• loose setscrews or keys in gears or shafts.....</li> <li>• bearings defective .....</li> </ul>	<ul style="list-style-type: none"> <li>drain, clean and lubricate the rolldrop</li> <li>inspect and repair as necessary</li> <li>inspect and replace as necessary</li> </ul>

---

## 3.5 Repairing the Rolldrop

**Important!**

- It is your responsibility to determine when to replace parts. When considering whether to continue using a part or to replace it, remember that replacing it is the best way to avoid further equipment damage.
- Replace all spring pins and retaining rings when you disassemble the rolldrop or brake for repair or replacement.
- Appoint a qualified person to be responsible for all repairs to the equipment.

- 3.5.1 GET FACTORY AUTHORIZATION for all repairs. Unauthorized repairs will void the warranty, and may lead to damage or failure of the rolldrop.
- 3.5.2 REPLACE DAMAGED OR POORLY OPERATING PARTS with Thern repair parts.
- 3.5.3 REFINISH AREAS where the paint is worn or flaking. A good finish helps to protect against corrosion and weather damage.
  - a REMOVE THE FINISH from damaged areas, down to the bare metal.
  - b CLEAN THE AREA thoroughly.
  - c REPAINT with a high quality primer and finishing coat.
- 3.5.4 TO ORDER REPAIR PARTS, contact your local dealer. Include the following information when ordering:
  - model number
  - serial number (or code number)
  - part number
  - date purchased, and from whom
  - description of what happened, or what is wrong
  - your name and return address

**Important!**

- Keep a record of what you ship, and when you send it.

**Rolldrop Handling Instructions****Do the following:**

- Always remove the reducer and couplings before lifting.
- Always lift from two different points. Make sure the lift points are at least 5ft on either side of the center of the drum when attempting to lift from the drum center. Make sure the lift points are on the drum pipe near the ends when attempting to lift from the drum ends.

**Don't do the following:**

- Never attempt to lift the roll drop from a single center point.
- Never handle the roll drop with the reducer and couplings attached.
- Never move the roll drop with jerky movements.

---

## 4.1 Transporting the Rolldrop

4.1.1 REMOVE THE BREATHER PLUG and install a sealed plug to prevent the loss of lubrication during shipment.

**Motovario reducers are maintenance free and do not require a breather.**

4.1.2 PACK THE ROLLDROP in a horizontal position (not upside down) for transport, using the original packaging materials, if possible.

- FASTEN THE ROLLDROP to a wooden base using bolts, to keep it from moving during transport.
- SEAL THE ROLLDROP in plastic with a desiccant to help protect it from rust, corrosion, and other damage.
- CONSTRUCT WOODEN SIDES and top to enclose the rolldrop in a solid protective crate.
- PACK LOOSE PARTS in small boxes or ship separately.

4.1.3 INSPECT THE ROLLDROP according to the Instructions for Periodic Inspection before installing it in a new location.

---

## 4.2 Storing the Rolldrop

4.2.1 FILL THE REDUCER with lubricant, and make sure the breather plug is clean and properly installed. Add a rust preventative for long term storage. Follow the reducer manufacturer's instructions.

**Motovario reducers are maintenance free and do not require a breather.**

4.2.2 SEAL THE ROLLDROP in plastic with a desiccant to help protect it from rust, corrosion, and other damage.

4.2.3 STORE THE ROLLDROP upright, in a cool clean place away from corrosive chemicals and moisture.

4.2.4 ROTATE THE DRUM PERIODICALLY to keep bearing and gears surfaces from becoming lacquered. Release the brake to rotate the drum.

4.2.5 INSPECT THE ROLLDROP according to the Instructions for Periodic Inspection before installing it for operation.

4.2.6 TEST INSULATION RESISTANCE in the motor to detect moisture damage. Refer to the motor manufacturer's instructions.

4.2.7 DRAIN THE REDUCER and fill with proper lubricant prior to operation. See section 3.3 Lubricating the Rolldrop.



**Thern Stage Equipment  
5712 Industrial Park Road  
Winona, MN 55987**

**PHN 507-454-2996  
FAX 507-454-5282**

**EMAIL: [info@thernstage.com](mailto:info@thernstage.com)  
[www.thernstage.com](http://www.thernstage.com)**