



Read this Owner's Manual thoroughly before operating the equipment. Keep it with the equipment at all times. Replacements are available from Thern Stage Equipment, 5712 Industrial Park Road, Winona, MN 55987, 507-454-2996. www.thernstage.com

IMPORTANT: Please record product information on page 2. This information is required when calling the factory for service.



Owner's Manual

For
CW11 and CW25 Series
Clew Winches

Two-Year Limited Warranty

Please record the following:

Date Purchased: _____

Model Number: _____

Serial Number: _____

This information is required when calling the factory for service.

Thern, Inc. warrants its products against defects in material or workmanship for two years from the date of purchase by the original using buyer, or if this date cannot be established, the date the product was sold by Thern, Inc. to the dealer. To make a claim under this warranty, contact the factory for an RGA number. The product must be returned, prepaid, directly to Thern, Inc., 5712 Industrial Park Road, Winona, Minnesota 55987. The following information must accompany the product: the RGA number, the date of purchase, the description of the claimed defect, and a complete explanation of the circumstances involved. If the product is found to be defective, it will be repaired or replaced free of charge, and Thern, Inc. will reimburse the shipping cost within the contiguous USA.

This warranty does not cover any damage due to accident, misuse, abuse, or negligence. Any alteration, repair or modification of the product outside the Thern, Inc. factory shall void this warranty. This warranty does not cover any costs for removal of our product, downtime, or any other incidental or consequential costs or damages resulting from the claimed defects. This warranty does not cover brake discs, wire rope or other wear components, as their life is subject to use conditions which vary between applications.

FACTORY AUTHORIZED REPAIR OR REPLACEMENT AS PROVIDED UNDER THIS WARRANTY IS THE EXCLUSIVE REMEDY TO THE CONSUMER. THERN, INC. SHALL NOT BE LIABLE FOR ANY INCIDENTAL OR CONSEQUENTIAL DAMAGES FOR BREACH OF ANY EXPRESS OR IMPLIED WARRANTY ON THIS PRODUCT. EXCEPT TO THE EXTENT PROHIBITED BY APPLICABLE LAW, ANY IMPLIED WARRANTY OF MERCHANTABILITY OR FITNESS FOR A PARTICULAR PURPOSE ON THIS PRODUCT IS LIMITED IN DURATION TO THE DURATION OF THIS WARRANTY.

Some states do not allow the exclusion or limitation of incidental or consequential damages, or allow limitations on how long an implied warranty lasts, so the above limitation or exclusion may not apply to you. This warranty gives you specific legal rights, and you may also have other rights which vary from state to state.

Note: Thern, Inc. reserves the right to change the design or discontinue the production of any product without prior notice.

About This Manual

The Occupational Safety and Health Act of 1970 states that it is the employer's responsibility to provide a workplace free of hazard. To this end, all equipment should be installed, operated, and maintained in compliance with applicable trade, industrial, federal, state, and local regulations. It is the equipment owner's responsibility to obtain copies of these regulations and to determine the suitability of the equipment to its intended use.

This Owner's Manual, and warning labels attached to the equipment, are to serve as guidelines for hazard-free installation, operation, and maintenance. They should not be understood to prepare you for every possible situation.

The information contained in this manual is applicable only to the Thern CW11 and CW25 Series Clew Winches. Do not use this manual as a source of information for any other equipment.

The following symbols are used for emphasis throughout this manual:

⚠WARNING

Failure to follow 'WARNING!' instructions may result in equipment damage, property damage, and/or serious personal injury.

⚠CAUTION

Failure to follow 'CAUTION!' instructions may result in equipment damage, property damage, and/or minor personal injury.

Important!

Failure to follow 'important!' instructions may result in poor performance of the equipment.

Suggestions for Safe Operation

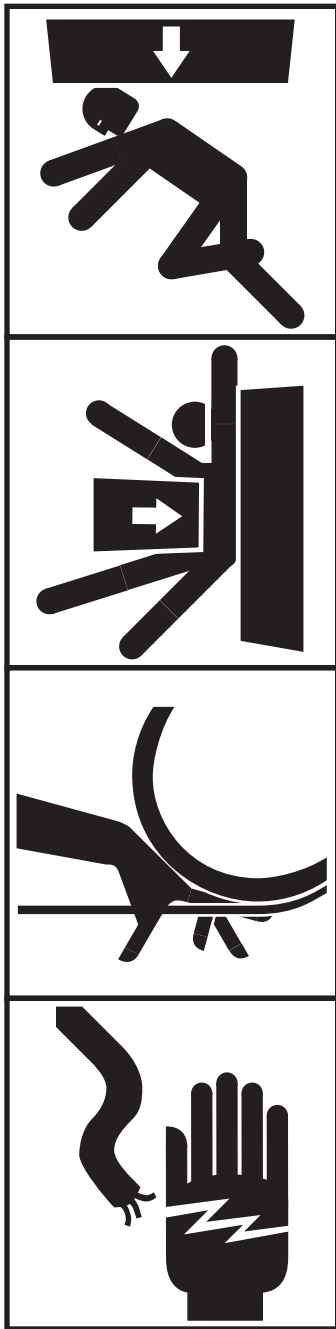

⚠WARNING

DO the following:

Read and comply with the guidelines set forth in this Owner's Manual. Keep this manual, and all labels attached to the winch, readable and with the equipment at all times. Contact Thern, Inc. for replacements.

Check lubrication before use.

Install the wire rope securely to the winch drum.

Keep at least 4 wraps of wire rope wound on the drum at all times, to serve as anchor wraps. With less than 4 wraps on the drum the wire rope could come loose, causing the load to escape.

Keep hands away from the drum, wire rope, and other moving parts of the equipment.

Secure the drum with the drum lock before leaving the load suspended on manual clew winches only.

Keep all unnecessary personnel away from the winch while in operation. Keep out of the path of the load, and out of the path of a broken wire rope that might snap back and cause injury.

Disconnect power before servicing equipment.

DO NOT do the following:

This product designed for lifting and moving material only. Do not use this product for any other purpose.

Do not exceed the load rating of the winch or any other component in the system. To do so could result in failure of the equipment.

Do not use more than one winch to move a load unless each winch was designed for use in a multiple winch system.

Do not use damaged or malfunctioning equipment. To do so could result in failure of the equipment.

Do not modify equipment in any way. To do so could cause equipment failure.

Do not wrap the wire rope around the load. This damages the wire rope and could cause the load to escape. Use approved rigging connectors to secure the wire rope to the load.

Do not divert your attention from the operation. Stay alert to the possibility of accidents, and try to prevent them from happening.

Do not jerk or swing the load. Avoid shock loads by starting and stopping the load smoothly. Shock loads overload the equipment and may cause damage.

Do not adjust the winch brake with the load suspended.

Do not exceed the duty cycle rating when drill-driven or motorized. See Table 1.

Do not operate the manual winch with a drill-motor that exceeds 400 rpm or an impact wrench. To do so could result in equipment damage or failure.

Do not attempt to operate the manual winch with the drum lock installed in the drum flange.

Do not use or install drum lock in the drum flange on motorized clew winches.

Do not operate hoist with guards or covers removed or improperly installed.

Table 1 – Duty Rating

Series	Winch Duty Cycle Rating when drill-driven or motorized
CW11	15 minutes
CW25	15 minutes

Do not continue to operate drill-driven or motorized winch when gearbox or brake show signs of overheating.

Allow winch to cool to ambient temperature before continuing operation.

1.1 Installing the Winch

Important!

- Inspect the winch immediately following installation according to the Instructions for Periodic Inspection. This will give you a record of the condition of the winch with which to compare future inspections.
- A qualified professional should inspect or design the foundation to insure that it will provide adequate support.
- Do not weld the winch frame to the foundation or support structure. Welding the frame may void warranty, contact Thern, Inc. Use fasteners as instructed.

⚠WARNING

Do not install the winch in an area defined as hazardous by the National Electric Code, unless installation in such an area has been thoroughly approved.

Do not install the winch near corrosive chemicals, flammable materials, explosives, or other elements that may damage the winch or injure the operator. Adequately protect the winch and the operator from such elements.

Position the winch so the operator can stand clear of the load, and out of the path of a broken wire rope that could snap back and cause injury.

Attach the winch to a rigid and level foundation that will support the winch and its load under all load conditions, including shock loads.

- 1.1.1 CONSULT APPLICABLE CODES AND REGULATIONS for specific rules on installing the equipment.
- 1.1.2 LOCATE THE WINCH in an area clear of traffic and other obstacles. Make sure the winch is accessible for maintenance and operation.
- 1.1.3 LOCATE THE WINCH in an area with adequate temperatures. The winch is rated for operation in ambient temperatures ranging from 0° to 100° F.
- 1.1.4 POSITION THE WINCH to allow access for proper lubrication.
 - a **THE WINCH FRAME has two sets of mounting holes, one for base mounting and one for wall mounting.** The winch can be fastened to horizontal or vertical structures without modification. See Figure 2.
- 1.1.5 MAINTAIN A FLEET ANGLE up to 1 1/2 degrees for smooth drums and 2 degrees for grooved drums. The proper fleet angle minimizes wire rope damage by helping the wire rope wind uniformly onto the drum. See Figure 1.
- 1.1.6 FASTEN THE WINCH securely to the foundation.
 - a FOR STANDARD PRODUCTS referred to in this manual, use 1/2 inch coarse thread fasteners, grade 5 or better, torqued dry to 75 ft-lbs without lubrication. Make sure the winch frame is secured to a solid foundation able to support the winch and the load under all conditions with design factors based on accepted engineering practices. We recommend using a steel plate when fastening the winch to a wall.
 - b NON-STANDARD PRODUCTS that vary from the original design may have different fastening requirements. Contact a structural engineer or Thern, Inc. for this information.

TO COMPLY WITH LOCAL CODES, CONTACT A QUALIFIED PROFESSIONAL TO OBTAIN PROPER STRUCTURE OR FOUNDATION SPECIFICATIONS FOR THE MOUNTING OF THERN PRODUCTS.

Important!

- Install sheaves, guide wires and other equipment so they will remain fixed under all load conditions. Follow the recommendations of the equipment manufacturer.
- Use sheaves of proper diameter to minimize wear on the wire rope. Follow the recommendations of the sheave manufacturer.

Figure 1 – Maintaining the Fleet Angle

Install the winch to maintain the proper fleet angle as shown

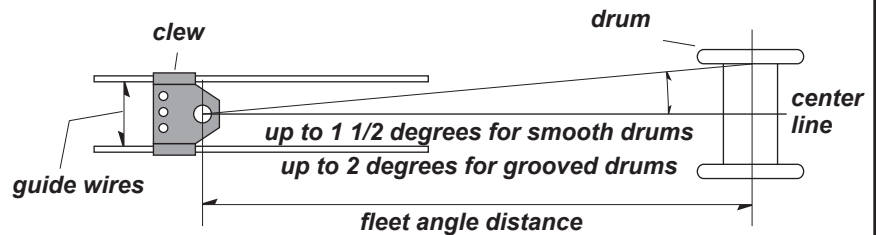
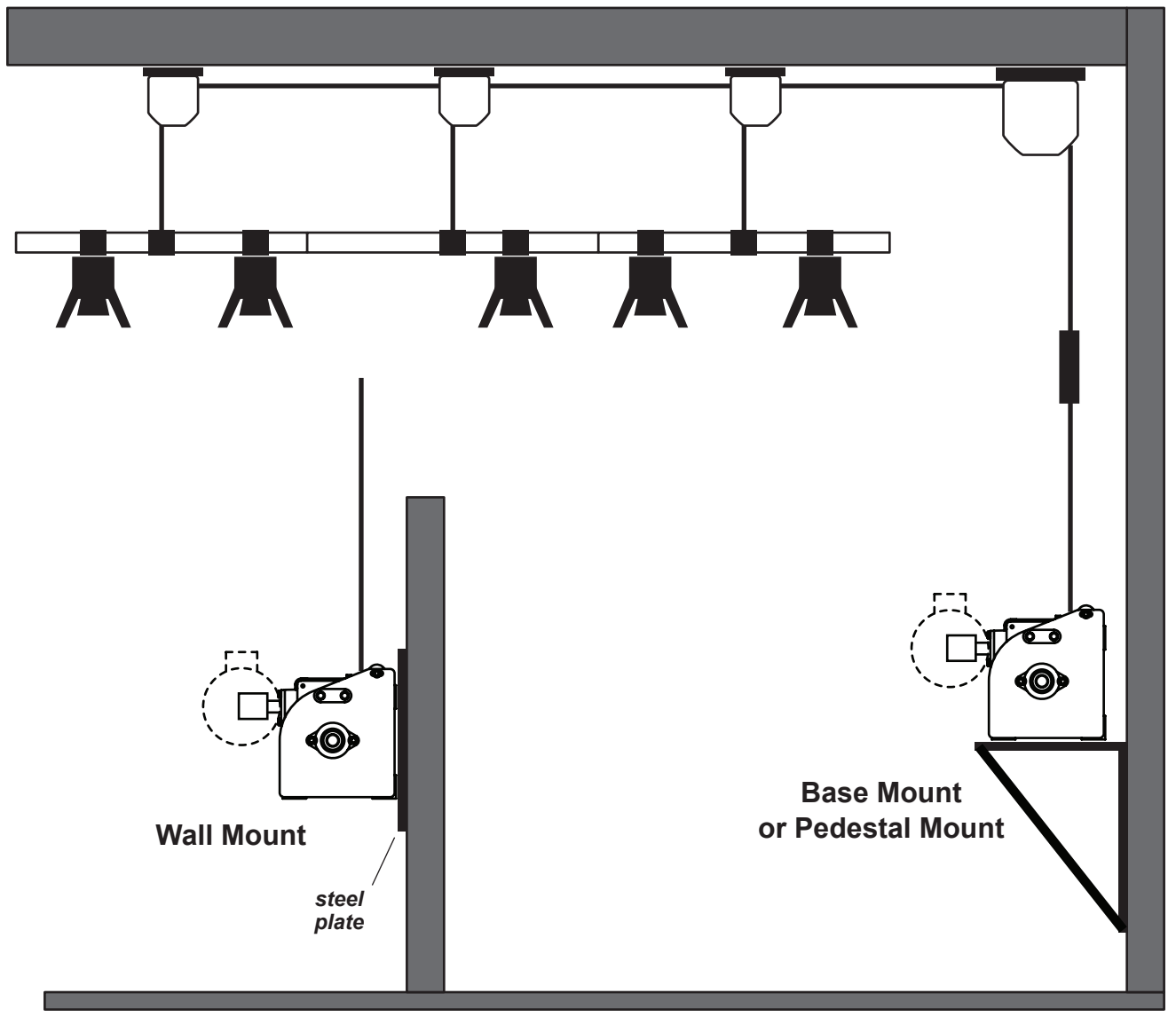

Figure 2 – Installing the CW Series Clew Winches



1.2 Connecting Power *(motorized units only)*

Important!

- Use components rated for the power supply you will be using.
- Always disconnect power when the winch is not in use.

⚠WARNING

Install proper branch circuit, disconnect devices, protection, and grounding as required by article 430 of the National Electric Code.

All electrical work must be performed by a licensed electrician. Failure to do so could result in electric shock or poor winch operation.

All control devices must be momentary contact type. Install all control devices so the winch motor will stop when the operator releases the device.

Locate control devices so the operator will be able to view the load through the entire operation.

Locate control devices so the operator will be clear of the load, the wire rope, and the path of a broken wire rope that could snap back and cause injury.

It is the responsibility of the owner to provide equipment for controlling the winch. Controls are available from Thern. The following guidelines are supplied as a reference for the installer.

- 1.2.1 CONSULT APPLICABLE CODES AND REGULATIONS for specific instructions regarding power supply installation and hookup.
- 1.2.2 INSTALL A FUSE OR CIRCUIT BREAKER, and a disconnect device in the power supply circuit, as required by the National Electric Code. The disconnect device should be a switch you can lock in the OFF position to prevent unauthorized use of the winch.
- 1.2.3 CONNECT ELECTRICAL POWER SUPPLY, with ground wire, to the electric starter control box. Check the component manufacturer's information for a wiring diagram.
- 1.2.4 CONNECT OTHER ELECTRIC EQUIPMENT to the proper terminals in the electric control box.
- 1.2.5 INSTALL A CONTROL DEVICE in the power supply line and connect power to the motor. Make sure the control device is a momentary contact type so the motor will stop when the operator releases the control. Wire the load brake for fast braking on brakemotors that offer this function. Check the component manufacturer's information.
- 1.2.6 CONNECT OTHER EQUIPMENT to the power supply as necessary.
- 1.2.7 CHECK POWER SUPPLY at the motor and make sure it agrees with the motor rating. Do not operate the winch until proper power is supplied to the motor.
- 1.2.8 TEST ELECTRICAL CONNECTIONS by operating the winch.
 - a ROTATION OF THE DRUM must agree with the labels on the control device, either UP and DOWN, or FORWARD and REVERSE.
 - b CHECK THE MOTOR BRAKE, make sure it releases when the motor is ON, and engages when the motor is OFF.

CONTACT THE FACTORY OR A QUALIFIED PROFESSIONAL FOR HELP.

1.3 Installing the Breather Plug

Important!

- Save the extra oil plug for use when the winch is removed for storage or transport.

CAUTION

Install the breather plug to vent heat and pressure from the gearbox and brake. Failure to do so could result in pressure buildup which can cause the gearbox or brake to leak or damage the equipment.

For shipment, the gearbox and brake are filled with lubricant and sealed with oil plugs. The breather plug is attached to the gearbox or shipped in a separate envelope.

1.3.1 REMOVE THE OIL PLUG and install the breather plug in the proper location. Make sure the breather plug is above the lubricant level. See Figure 3.

1.3.2 CHECK LUBRICANT LEVEL in the gearbox and brake to make sure no lubricant was lost during shipment. See Section 3.3 Lubricating the Winch.

Figure 3 – Installing the Breather Plug(s)

CW11 Series

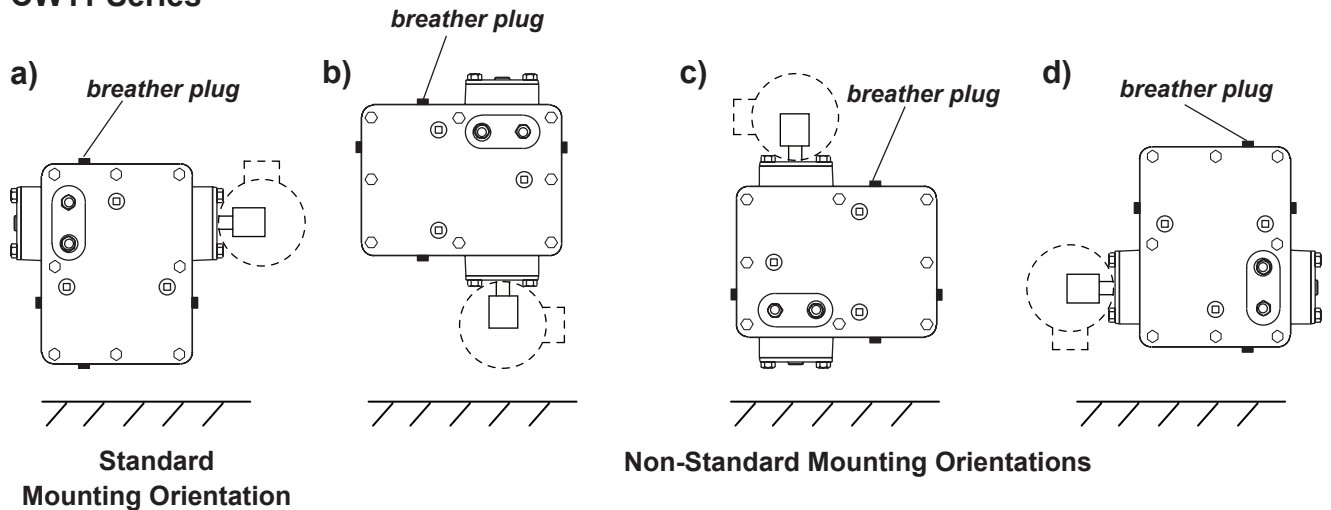

CW25 Series

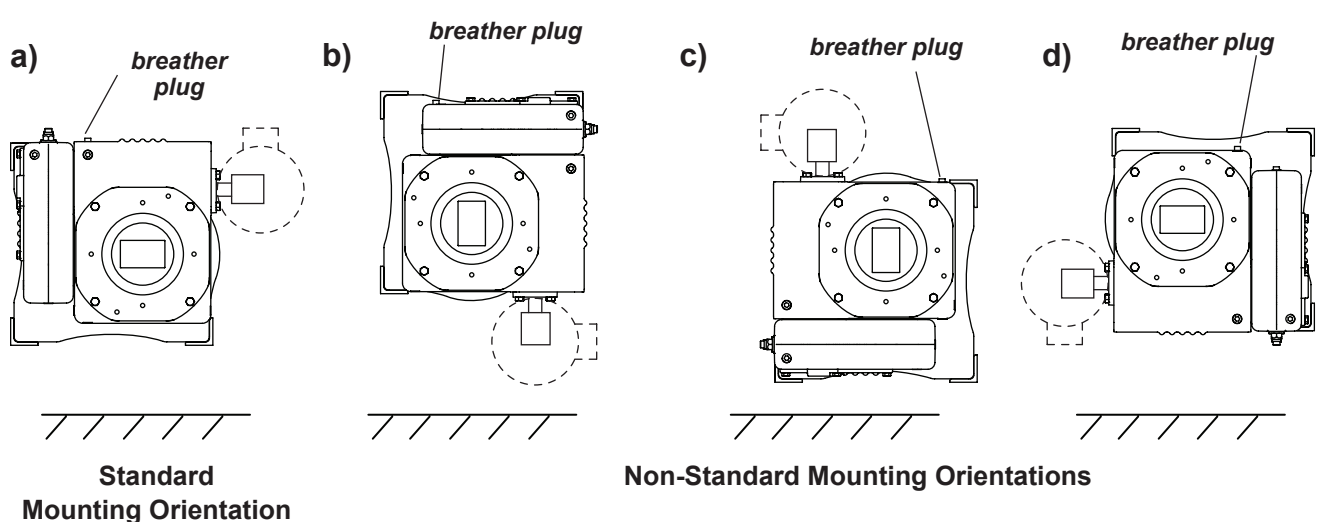

1.4 Removing Motor Drain Plugs

Some electric motors are equipped with screw plugs which are designed to be removed to provide drain holes.

1.4.1 LOCATE THE LOWEST POINT ON THE ELECTRIC MOTOR.

1.4.2 REMOVE THE SCREW PLUG located at this lowest point. See Figure 4.

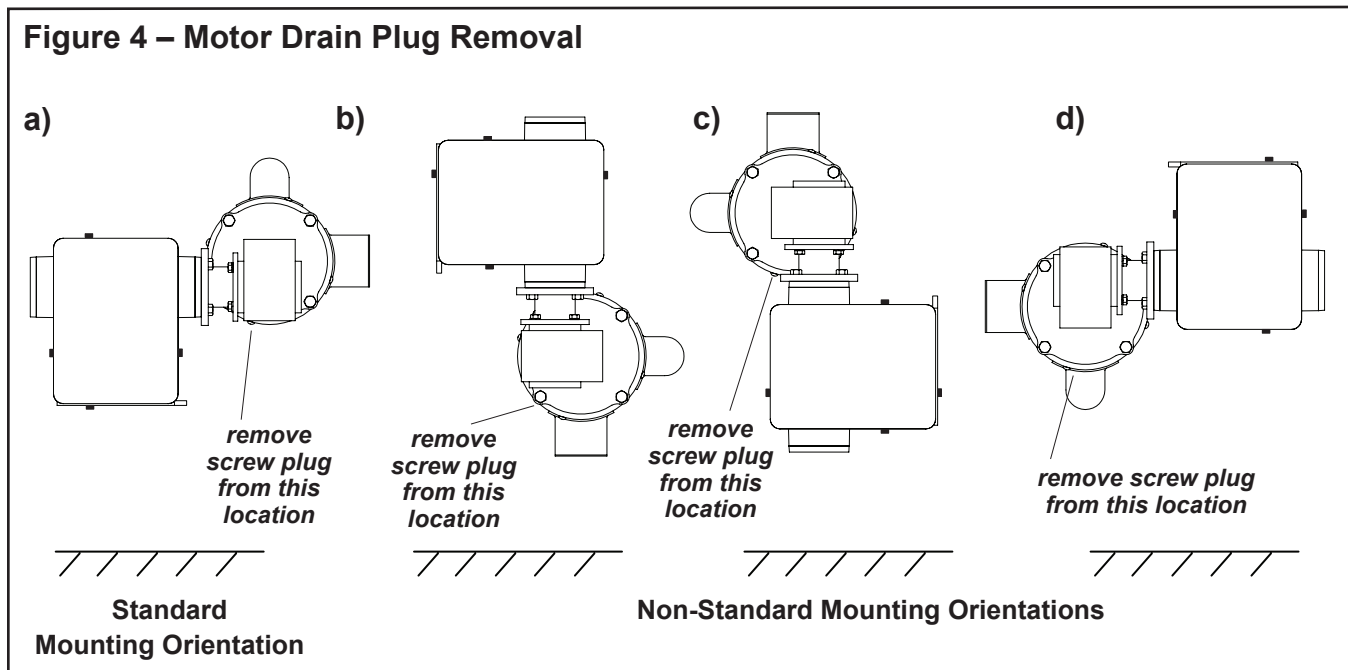

1.5 Installing the Guide Wires

Important!

- Consult a qualified professional to determine best methods for installing guide wires and other rigging components. All rigging components, including the structures they are mounted to, must be adequately sized for all load conditions. Tension in the guide wires creates additional loading that must be accounted for.

⚠ CAUTION

Do not exceed 100 lbs maximum line tension on guide wires, as this could damage the equipment. Consult a qualified professional and comply with local codes and standards.

Thern Clew Winches include a guide bar, shaft collars and guide plates. Guide wires and other rigging components must be purchased separately.

THE CW11 SERIES is designed for clews up to 9 1/2 inches wide.

THE CW25 SERIES is designed for clews up to 14 1/2 inches wide.

Figure 5 – Aligning the Guide Bar – CW Series

position guide bar horizontally to align with wire rope when drum is full

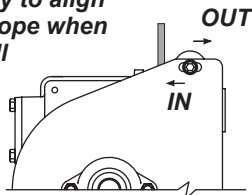

1.5.1 ATTACH GUIDE WIRES to the guide bar using approved rigging hardware and secure alignment by fastening 1 shaft collar on each side of the guide wires. See Figure 6.

1.5.2 ALIGN THE GUIDE BAR HORIZONTALLY by moving the guide bar in or out and tightening the fasteners with an Allen wrench. The guide bar should be positioned according to the maximum amount of wire rope that will be wound onto the drum during operation. See Figure 5.

- FOR SPOOLING WIRE ROPE ON SINGLE LAYER ONLY, position the guide bar IN toward the drum.
- FOR SPOOLING WIRE ROPE ON MULTIPLE LAYERS, position the guide bar OUT away from the drum.

Figure 6 – Installing Guide Wires – CW Series

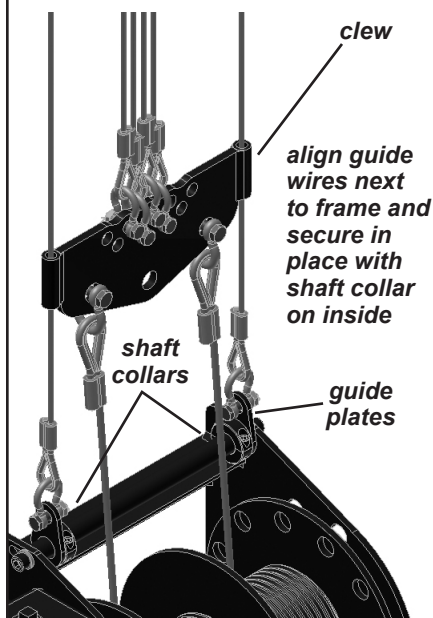

1.6 Installing the Handle

Figure 7 – Installing the Handle – CW Series

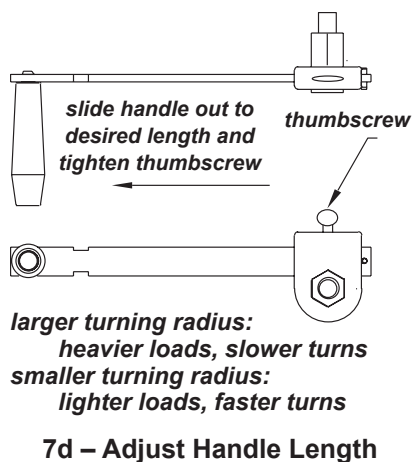
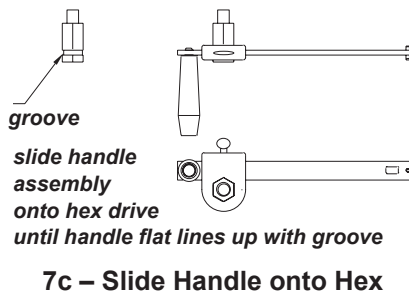
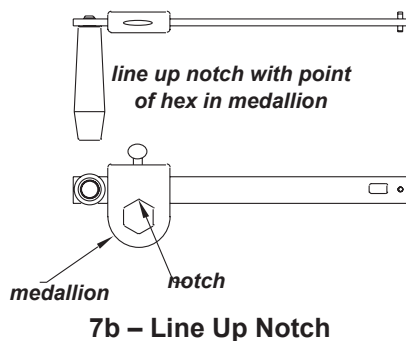
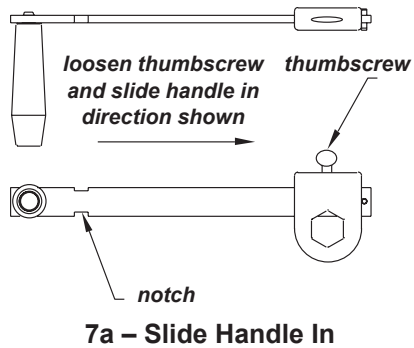

The manual winch includes a 1-1/8 inch hex drive input. You can attach the handle to this input, or you can use a 1-1/8 inch hex socket to power drive the winch with a maximum 400 rpm drill-motor. **Remove the handle before power driving the winch with a drill-motor.**

1.6.1 INSTALL THE HANDLE as follows. See Figure 7.

- a LOOSEN THE THUMBSCREW and slide the handle toward the medallion as shown. See 7a.
- b LINE UP THE NOTCH in the handle with the point of the hex in the medallion. See 7b.
- c SLIDE THE HANDLE AND MEDALLION ASSEMBLY onto the hex drive until the flat of the handle lines up with the groove in the hex drive. See 7c.
- d SLIDE THE HANDLE outward away from the medallion to the desired length and tighten the thumbscrew. See 7d.

1.7 Installing the Wire Rope

Important!

- Use wire rope and other rigging equipment rated for the size of the largest load you will be moving.
- Do not drag the wire rope through dirt or debris that could cause damage, or poor operation.
- Always wear protective clothing when handling wire rope.

⚠WARNING

Install the wire rope securely to the winch drum. A poorly secured wire rope could come loose from its anchor and allow the load to escape.

Install the wire rope so it is wound correctly as shown or the winch and brake will not work properly, and could allow the load to escape, see Figure 8.

Figure 8 – Installing the Wire Rope

rotate handle COUNTER-CLOCKWISE to wind wire rope onto the drum on manual clew

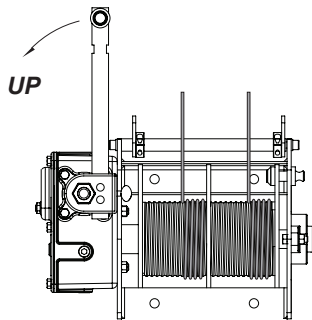

front view

install wire rope UNDERWOUND on drum as shown or winch and brake will not operate properly

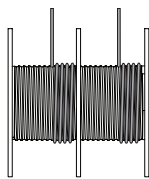

drum

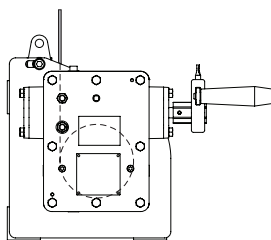

side view

- 1.7.1 PURCHASE THE PROPER WIRE ROPE for your application. Keep the following in mind when selecting a wire rope. Contact a reputable wire rope supplier for help.
 - a BREAKING STRENGTH of new wire rope should be at least 8 times greater than the largest load placed on an individual wire rope. This is a minimum value and will vary with the type of load and how you are moving it.
 - b WIRE ROPE LAY must agree with the winding direction of the drum to help insure proper winding.
 - c WE RECOMMEND 7 x 19 galvanized aircraft cable for diameters up to 5/16 inch, and 6 x 37 IWRC improved plow steel (IPS) or extra improved plow steel (EIPS) wire rope for diameters of 3/8 inches and up.
- 1.7.2 ANCHOR THE WIRE ROPE to the drum using the key slot anchor. **A swaged ball or other approved anchor fitting must be attached to the end of the wire rope.**
 - a PASS THE WIRE ROPE under the drum and position the anchor fitting in the key slot in the drum.
 - b PULL THE WIRE ROPE to firmly lodge the anchor fitting in the narrowest part of the key slot. Make sure the wire rope remains securely anchored as wire rope is wound onto the drum.
- 1.7.3 INSTALL THE WIRE ROPE SO IT IS UNDERWOUND on the drum as shown, or the winch and brake will not work properly and could allow the load to escape.
- 1.7.4 TURN THE HANDLE COUNTER-CLOCKWISE to wind wire rope onto the drum on manual clew winches. If wire rope unwinds from the drum when the handle is rotated counter-clockwise, the wire rope is installed incorrectly. **Install the wire rope correctly before continuing.**
- 1.7.5 WIND FOUR FULL WRAPS of wire rope onto the drum by operating the winch while holding the wire rope taught. **These wraps serve as anchor wraps and must remain on the drum at all times.**

1.8 Setting Travel Limits *(motorized units only)*

Figure 9 – Setting Travel Limits

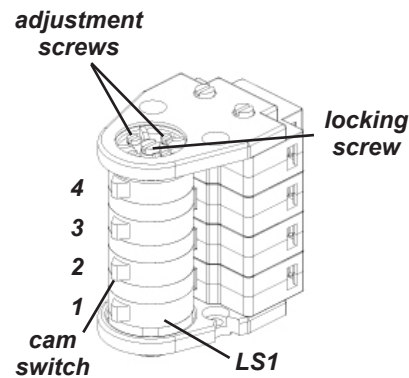

Switch	Position	Travel
LS1	Up	Overtravel
LS2	Up	Normal Limit
LS3	Down	Normal Limit
LS4	Down	Overtravel

⚠ CAUTION

Limit set points are dependant on speed of operation. Use caution with setting limits on units with variable speed operation. Typically, limits should be for the highest speed to be encountered.

Correct setup may take some trials and adjustments.

Standard motorized units are shipped with TER limit switches. For motorized units equipped with other limit switches, refer to manufacturer's instructions.

Each unit's travel is controlled by two sets of limit switches driven from the gear box output shaft. One set controls the normal movement (normal limit) of the unit. The other set (overtravel) are there to indicate an overtravel in the event of a failure to the travel limits.

The overtravel limits should be set first to determine the absolute maximum range of travel that the unit is able to run securely. The normal travel limits should be set within this range to limit the movement of the normal operating range.

1.8.1 SET LIMITS by doing the following. **Overtravel limits should be set before travel limits. Refer to manufacturer's instructions. See Figure 9.**

- a REMOVE the limit switch cover.
- b LOOSEN the large locking screw in the center of the column. Individual limits can now be set.
- c DETERMINE WHICH DIRECTION the limit switch cam rotates when the "UP" button is pressed.
- d TURN THE SCREW labeled "1" so that the microswitch is hit by the cam when the load "opens" to the desired position. The lower limit "4" should be adjusted so that the microswitch is hit by the cam as the unit moves into position in the "DOWN" direction.
- e REPEAT THE PROCESS with screws labeled "2" and "3" to set the normal operating travel limits.
- f AFTER SETTING BOTH LIMITS the locking screw can be tightened and the limits re-checked.
- g REPLACE the cover.

2.1 General Theory of Operation

Important!

- Limit nonuniform winding by keeping tension on the wire rope and by maintaining the proper fleet angle.
- It is your responsibility to detect and account for different factors affecting the condition and performance of the equipment.

Table 1 – Duty Rating

Winch Series	Duty Cycle Rating when drill-driven or motorized
CW11	15 minutes
CW25	15 minutes

Do not continue to operate drill-driven or motorized winch when gearbox or brake show signs of overheating.

Allow winch to cool to ambient temperature before continuing operation.

- 2.1.1 THE FORCE REQUIRED to move the load must not exceed the load rating of the winch. Consider the total force required to move the load, not the weight of the load.
- 2.1.2 THIS EQUIPMENT CAN develop forces that will exceed the load rating. It is the responsibility of the equipment user to limit the size of the load. Inspect the equipment regularly for damage according to the instructions contained in this manual.
- 2.1.3 USE THE DRUM LOCK to secure the drum when the winch is not in use on **manual clew winches only**. This prevents unauthorized use of the equipment and also functions as a load holding device.
- 2.1.4 PERFORMANCE RATINGS of the equipment are affected by the amount of wire rope wound on the drum, the way in which it is wound, and the way the winch is used.
- a DRUM CAPACITY depends on how tightly and evenly the wire rope is wound on the drum. Actual drum capacities are usually 25-30% less than values shown in performance tables, due to loose winding and overlapping.
 - b FORCE REQUIRED TO LIFT the load increases with each additional layer of wire rope wound onto the drum. Line speed also increases with each additional layer of wire rope wound onto the drum.
 - c LOAD RATING represents the maximum pull that can be placed on new equipment. Load ratings are assigned values for specific amounts of load travel or wire rope accumulation. The load rating decreases as layers of wire rope accumulate on the drum. The load rating may decrease when operated with a drill-motor, check the winch nameplate for ratings.
- 2.1.5 DUTY RATINGS refer to the type of use the equipment is subject to. Consider the following when determining duty rating. **Duty cycle ratings are based on operation with a maximum 400 rpm drill-motor with the manual clew. Length of operation with motorized models should not exceed the duty cycle rating. See Table 1.**
- a ENVIRONMENT: harsh environments include hot, cold, dirty, wet, corrosive, or explosive surroundings. **Protect the equipment from harsh environments when possible.**
 - b MAINTENANCE: poor maintenance, meaning poor cleaning, lubrication, or inspection, leads to poor operation and possible damage of the equipment. **Minimize poor maintenance by carefully following the instructions contained in this manual.**
 - c LOADING: severe loading includes shock loading and moving loads that exceed the load rating of the equipment. **Avoid shock loads, and do not exceed the load rating of the equipment.**
 - d FREQUENCY OF OPERATION: frequent or lengthy operations increase wear and shorten the life span of gears, bearings, and other components. **Increase maintenance of the equipment if used in frequent operations.**

CONTACT THE FACTORY FOR MORE INFORMATION.

2.2 Breaking-In the Winch

- 2.2.1 BREAK-IN OCCURS during the first few hours of normal operation. During break-in, mating surfaces become polished, and clearances increase. This is desired for efficient operation of bearings and gears.
- 2.2.2 INSPECT THE WINCH following break-in according to the Instructions for Periodic Inspection. See Section 3.4 Inspecting the Equipment.

2.3 Preparing for Operation

Important!

- When determining whether the load will exceed the load rating, consider the total force required to move the load.

- 2.3.1 CONSIDER THE OPERATION. Do not begin until you are sure you can perform the entire operation without hazard.
- 2.3.2 BEFORE INITIAL OPERATION inspect the winch and all components of the system.
- a INSPECT THE WINCH and other equipment according to the Instructions for Frequent Inspection. Do not operate winch until all defects have been corrected. See Section 3.4 Inspecting the Equipment.
- 2.3.3 BEFORE EACH OPERATION inspect all components of the system.
- a OPERATORS must be in good health, alert, and thoroughly trained in operating the equipment, and properly clothed (safety equipment as required, no loose clothing, and no loose jewelry).
- b THE LOAD must be clear of other objects and free to move. Make sure the load will not tip, bind, or in any way move uncontrollably.
- 2.3.4 KNOW YOUR LOAD and make sure you do not exceed the load rating of the winch or other equipment in the system.

Figure 10 – Attaching the Load – CW Series

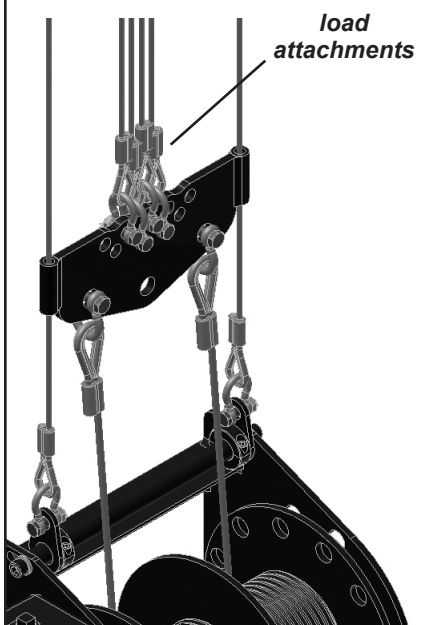

2.4 Attaching the Load

⚠ WARNING

Do not wrap the wire rope around the load. This damages the wire rope and could cause the load to escape. Use a sling or other approved lifting device.

- 2.4.1 CLEAR OBJECTS from the path of the load so you can move it freely and observe it at all times during the operation.
- 2.4.2 MAKE SURE THE WIRE ROPE is not twisted. A twisted wire rope could cause objects to spin and can cause premature wear of wire rope.
- 2.4.3 ATTACH THE LOAD using a clew or other approved lifting device. Follow the recommendations of the manufacturer. See Figure 10.

2.5 Moving the Load

Important!

- Obey a stop signal from anyone.
- Maintain tension on the wire rope to keep it tightly and evenly wound on the drum.
- If the winch and load are not visible during the entire operation, get help from another person.
- Appoint a supervisor if more than one person is involved in the operation. This will reduce confusion and increase safety.
- Remove the winch handle and secure the drum using the drum lock when the winch is not in use, to help avoid unauthorized use on the manual clew winch only. See Figure 11.

Figure 11 – Drum Lock on Manual Clew Winch



Table 1 – Duty Rating

Winch Series	Duty Cycle Rating when drill-driven or motorized
CW11	15 minutes
CW25	15 minutes

Do not continue to operate drill-driven or motorized winch when gearbox or brake show signs of overheating.

Allow winch to cool to ambient temperature before continuing operation.

- 2.5.1 **MOVE THE LOAD** slowly and smoothly, only a small distance at first. Make sure the load is balanced and securely attached before continuing.
- 2.5.2 **VERIFY CORRECT INSTALLATION OF WIRE ROPE.** Wire rope should be underwound as shown in Figure 8 or the winch and brake will not work properly. Turning the handle counter-clockwise on manual winches should cause wire rope to wind onto the drum.
- 2.5.3 **USE THE CONTROL DEVICE** to operate the motorized winch. The control device should be momentary contact type, so the winch will stop when the operator releases the control.
- 2.5.4 **OBSERVE THE WIRE ROPE** as it winds onto the drum. If it becomes loose, uneven, or overlapped, stop the operation and rewind the wire rope before continuing. **Continued operation with overlapped or uneven wire rope can damage the wire rope and shorten its life.**
- 2.5.5 **A MAXIMUM 400 RPM DRILL-MOTOR** can be used to operate the manual winch models only by following the guidelines below.
 - a **DO NOT EXCEED THE DUTY CYCLE RATING of the manual winch when operating with drill-motor. The motorized winch is rated for the same duty cycle. See Table 1.**
 - b **ALLOW THE WINCH AND BRAKE TO COOL DOWN** to ambient temperature in rest periods between operations.
 - c **USE A 1-1/8 INCH HEX SOCKET** to power drive the input shaft on the manual clew winch models. The drill-motor should be set for low speed operation if possible. Thern recommends using a drill-motor rated for 400 rpm at 10 amps.
 - d **THE LOAD RATING OF THE MANUAL WINCH** may decrease when operated with a drill-motor. Check the winch nameplate for load ratings.
- 2.5.6 **OBSERVE THE GEARBOX AND BRAKE** during operation for signs of overheating. **Frequent overheating may be a sign of damage, or may indicate the need for a larger winch.**
 - a **WATCH FOR SMOKE**, the smell of burnt lubricant, and other signs of overheating. Use a thermocouple or other device to monitor gearbox and brake temperature. The temperature of the gearbox should not exceed 150° F.
 - b **STOP OPERATION** if the gearbox or brake overheats, and allow the winch to cool until it reaches ambient temperature. **Continued operation may cause damage.**

3.1 Cleaning the Winch

Important!

Increase the frequency of maintenance procedures if the winch is:

- Operated frequently.
- Used to move heavy loads.
- Operated in wet, dirty, hot, or cold surroundings.

Clean the winch to remove dirt and help prevent rust and corrosion.

- 3.1.1 CLEAN THE WINCH every 6 months or whenever it is dirty.
 - a WIPE ALL EQUIPMENT to remove dirt and grease.
 - b LEAVE A LIGHT FILM of oil on all surfaces to protect them against rust and corrosion.
 - c WIPE OFF excessive amounts of oil to avoid the accumulation of dirt.
- 3.1.2 REMOVE ALL UNNECESSARY OBJECTS from the area surrounding the winch.

3.2 Adjusting the Brakes

Important!

- Do not overtighten the brake, since this will cause parts to wear and become damaged.

⚠WARNING

Do not adjust either brake with the load suspended. Simultaneous accidental release of both brakes could allow the load to escape.

THE MOTORIZED CLEW MODELS also include a brake on the motor.

Figure 12a – Adjusting the Mechanical Brake

CW11 Series

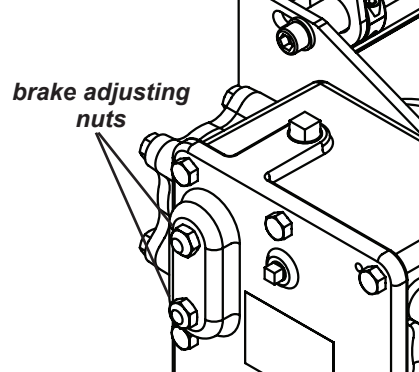

CW25 Series

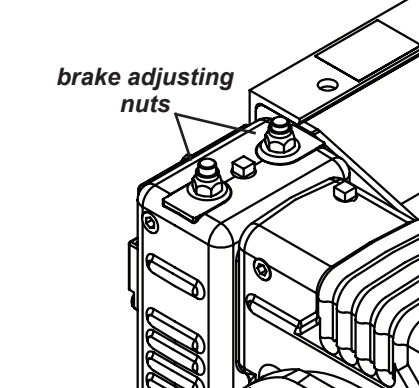
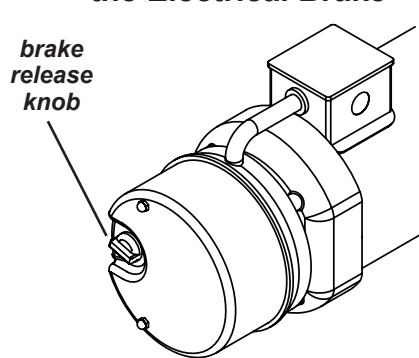

Figure 12b – Disengaging the Electrical Brake



3.2.1 ADJUST THE BRAKE whenever it appears to need adjustment, or at least every 3 months.

3.2.2 CHECK THE ELECTRIC BRAKE ON THE MOTOR (if equipped) by operating the winch with a test load equal to the winch load rating:

- DISENGAGE THE MECHANICAL BRAKE **under no load**. See Figure 12a.
- RAISE THE LOAD, then lower it and stop it about one foot off the ground.
- OBSERVE THE LOAD when stopped. If it continues to coast or creep, the brake needs adjustment. Refer to the brake manufacturer's instructions, or contact the factory for assistance.
- RE-ENGAGE THE MECHANICAL BRAKE by following the instructions below.

3.2.3 CHECK THE MECHANICAL BRAKE on the CW11 and CW25 series by operating with a test load equal to the winch load rating:

- DISENGAGE THE ELECTRICAL BRAKE (if equipped) **under no load**. Keep disengaged during procedures b and c below. See Figure 12b.
- RAISE THE LOAD, then lower it and stop it about one foot off the ground.
- OBSERVE THE LOAD when stopped. If it continues to coast or creep, follow the instructions below:
 - FOR MANUALLY OPERATED WINCHES, adjust the brake nuts according to the input shaft torque range specified for the winch, turning the nuts clockwise by 1/4 turns between torque readings. See Table 2. **Do not adjust the brake with the load suspended.**
 - FOR MOTORIZED WINCHES, tighten the brake by turning the adjusting nuts clockwise about 1/4 turn. Continue to test and tighten the brake by alternating the tightening of each brake nut until the brake stops and holds the load securely. See Figure 12b.
 - **DO NOT OVERTIGHTEN** mechanical brake adjusting nuts.
- RE-ENGAGE THE ELECTRICAL BRAKE (if equipped).

3.2.4 A DECELERATION DISTANCE while stopping is typically 6 inches.

3.2.5 IF THE LOAD CONTINUES TO COAST or creep, contact the factory.

Table 2 – Torque¹ While Lowering for CW-M Series

Unit	Under No Load	Under Load	Direction ²
CW11-M	2-4 ft-lbs	4-10 ft-lbs	clockwise
CW25-M	10-40 ft-lbs	min. 4 ft-lbs ³	clockwise

¹ Do not adjust brake with load suspended.

² Complete 1 full rotation of input shaft.

³ Tighten brake until the minimum value is obtained. See Figure 12a.

3.3 Lubricating the Winch

Important!

- Do not leave plug holes in the gearbox or brake open. Open plug holes will allow oil to leak out and dirt or moisture to contaminate the oil.
- Make sure lubricant has a temperature rating appropriate for the ambient temperatures of the operation.

Figure 13 – Outboard Bearing – CW Series

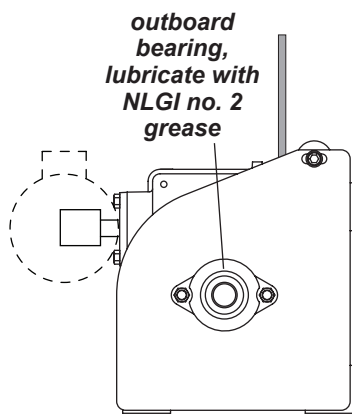

Important!

- For mounting positions b or c, remove unit from wall to allow oil to properly drain from the brake and gearbox. See Figures 14 and 15.

⚠ CAUTION

Install the breather plug to vent heat and pressure from the gearbox or brake. Failure to do so could result in pressure buildup which can cause the gearbox or brake to leak or damage the equipment.

Breather plug must be located above the oil level otherwise oil will leak through the plug. See Figures 14 and 15.

Check the gearbox and mechanical brake for proper level before operating. Too much or too little oil will cause overheating and result in equipment damage.

Lubricate the winch properly to help protect it from wear and rust. Apply thread sealant to pipe plugs when re-installing to prevent oil leaks. Read the following instructions carefully.

- 3.3.1 THE WINCH is shipped from the factory with the proper amount of Mobilgear 600XP220 lubricant in the gearbox and brake for mounting orientation "a". Lubricate the winch as follows. See Figures 14 and 15.
- 3.3.2 CHECK OIL LEVEL monthly. Remove the level check plug and make sure oil is even with the plug hole. Add oil to the gearbox and brake if necessary. **Do not use synthetic lubricants and do not mix different lubricants.**
- 3.3.3 CHANGE GEARBOX (AND MECHANICAL BRAKE) OIL at least every 12 months, or whenever it is dirty or contaminated. Remove the drain plug to drain oil from the gearbox and brake. See Figures 14 and 15.
 - a For the CW25 standard installations, fill the bottom compartment, then top compartment. Allow time for oil to settle and check oil level at level check plug. Apply thread sealant to pipe plug threads upon re-installation.
 - b For the CW25 non-standard mounting orientations (see Figure 15) fill the gearbox first, then brake. Allow time for oil to settle and check gearbox oil level at level check plug. Apply thread sealant to pipe plug threads upon re-installation.
- 3.3.4 LUBRICATE THE OUTBOARD BEARING at least once every month or more, depending on usage. Use a grease gun to insert NLGI no. 2 grease until clean grease appears at the seals. The bearing may squeak if it is dry. See Figure 13.
- 3.3.5 LUBRICATE THE WIRE ROPE and other equipment by following the manufacturers recommendations.

Figure 14 – Lubricating the Gearbox - CW11 Series

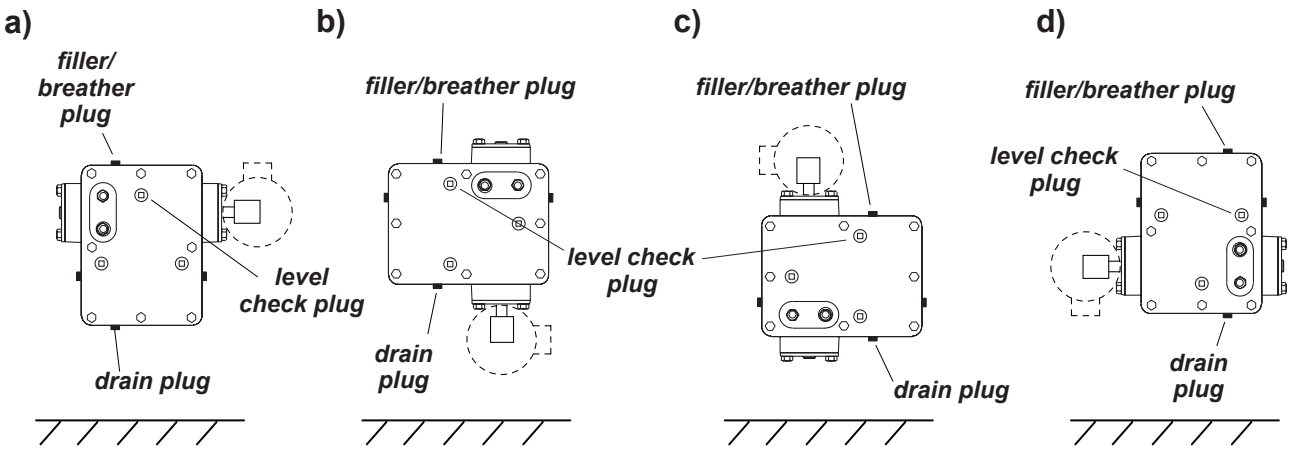

Standard Mounting Orientation

Non-Standard Mounting Orientations

Note: Drain plugs are hexagon socket pipe plugs. Do not remove bolts or nuts to drain oil.

Figure 15 – Lubricating the Gearbox - CW25 Series

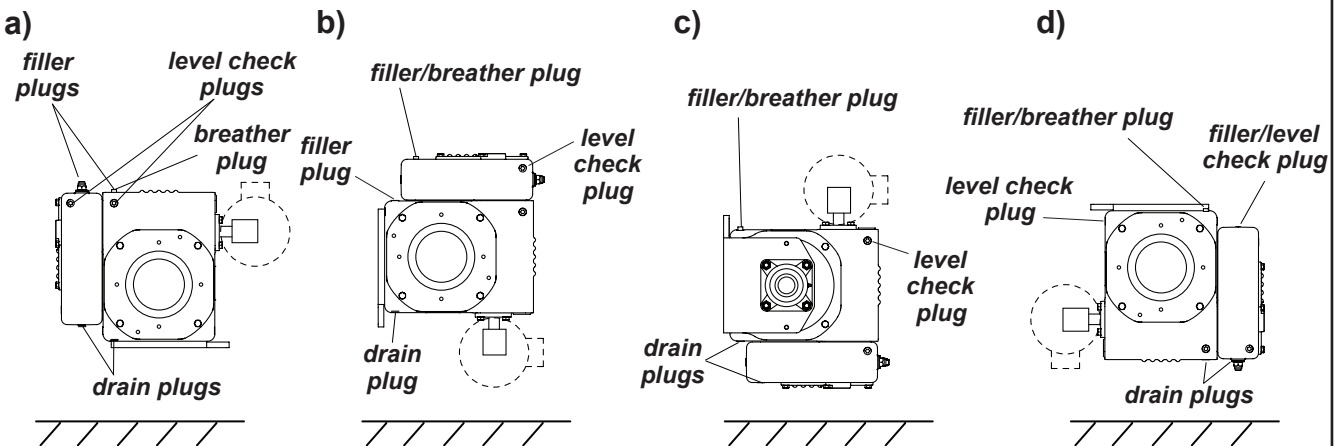

Standard Mounting Orientation

Non-Standard Mounting Orientations

Note: Drain plugs are hexagon socket pipe plugs. Do not remove bolts or nuts to drain oil.

3.4 Inspecting the Equipment

Important!

- Start an inspection program as soon as you put the winch into use.
- Appoint a qualified person to be responsible for regularly inspecting the equipment.
- Keep written records of inspection. This allows comparison with comments from previous inspections so you can see changes in condition or performance.

Perform frequent inspections:

- Monthly.
- Whenever you notice signs of damage or poor operation.

Frequent Wire Rope Inspection:

- Use ASME B30.7 as a guideline for rope inspection, replacement and maintenance.
- Check wire rope, end connections and end fittings for corrosion kinking, bending, crushing and bird-caging or other signs of damage.
- Check the number, distribution and type of visible broken wires. See paragraph 3.4.4 c and Figure 16.
- Check the wire rope for reduction of rope diameter from loss of core support, or wear of outside wires. See Figure 17.
- Take extra care when inspecting sections of rapid deterioration such as sections in contact with saddles, sheaves, repetitive pickup points, crossover points and end connections.

⚠WARNING

Do not use damaged or malfunctioning equipment. Place an “OUT OF ORDER” sign on the winch. Do not use the winch until the sign is removed by a qualified maintenance person who has completely corrected the problem. Disconnect power on motorized units before servicing equipment.

Do not operate the winch until proper power is supplied to the motor.

Inspect the winch to detect signs of damage or poor operation before they become hazardous.

3.4.1 CONSULT APPLICABLE CODES AND REGULATIONS for specific rules on inspecting the winch and other equipment.

3.4.2 CONSULT MANUFACTURER'S RECOMMENDATIONS for information on inspecting the wire rope and other equipment.

3.4.3 Instructions for Frequent Inspection

a VISUALLY INSPECT the entire winch and all other equipment involved in the operation.

- Check all equipment for cracks, dents, bending, rust, wear, corrosion and other damage.

- Make sure the wire rope is installed correctly and anchored securely to the drum.

- Make sure the thumbscrew or set screw holding the manual clew winch handle in place is tight.

- Make sure the winch is properly lubricated.

- Check the gearbox and mechanical brake for signs of leakage, and make sure it is filled with the proper lubricant. Contact the factory if there are any signs of lubricant leaking from the gearbox or brake housing.

- Make sure the breather plug is clean, open, and installed correctly.

- Make sure all fasteners including mounting fasteners are tight and secure.

- Make sure clew guide wires are snug. Guide wire tension should not exceed 100 lbs. See Section 1.5 Installing the Guide Wires.

- Make sure the foundation is in good condition, and capable of supporting the winch and its load under all load conditions.

b TEST WINCH PERFORMANCE by operating the winch with a load not exceeding the load rating.

- Listen for unusual noises, and look for signs of damage as you operate the winch.

- Make sure the wire rope winds evenly and tightly onto the drum. If it is loose or uneven, rewind it before continuing.

- Make sure the load moves smoothly, without hesitation or strain.

- Make sure the handle rotates freely in both directions for manual winch models.

- Check the brake. Raise the load, then lower it and stop it a few feet off the ground. If the load continues to coast or creep, the brake may be in need of repair or adjustment. See Section 3.2 Adjusting the Brake.

Completely correct all problems before continuing. Use the Troubleshooting Chart to help determine the cause of certain problems. See Table 4.

Perform periodic inspections:

- Every 12 months, or more frequently if drill-driven or motorized.
- Whenever you return the winch to service from storage.
- Whenever you notice damage or poor operation in a frequent inspection.
- Whenever you have, or think you may have, overloaded or shock loaded the winch.

Figure 16 – Broken Wires

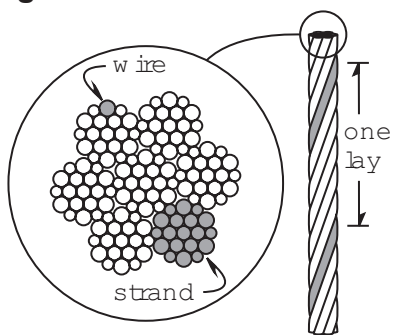

Wire rope assembly must be replaced if more than 6 wires are broken in one lay, or if more than 3 wires are broken in one strand in one lay.

Figure 17 – Rope Diameter

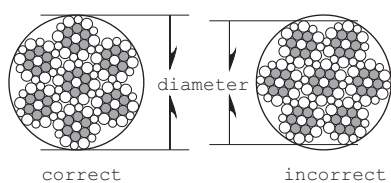

The wire rope assembly must be replaced if the diameter measures less than the minimum diameter at any point.

wire rope diameter	minimum diameter
3/16 in	11/64 in (.1719 in)
1/4 in	15/64 in (.2344 in)
5/16 in	19/64 in (.2969 in)
3/8 in	11/32 in (.3438 in)

3.4.4 Instructions for Periodic Inspection, see Table 3.

- VISUALLY INSPECT** the winch and all other equipment.
 - Disassembly may be required in order to properly inspect individual components. Contact factory for assembly/disassembly instructions. Disassembly of the gearbox or brake housing before contacting Thern, Inc. voids all warranties.
 - Check the finish for wear, flaking, or other damage.
 - Check all equipment for cracks, dents, bending, rust, wear, corrosion and other damage. If the equipment was overloaded, or if you notice cracks or other signs of overloading and damage, promptly remove equipment from use and have it repaired or replaced. **DO NOT CONTINUE TO USE DAMAGED OR OVERLOADED EQUIPMENT OR WIRE ROPE.**
 - Check all fasteners for stripped threads, wear, bending, and other damage.
 - Check the gearbox and brake housing for signs of leakage. Contact the factory if there are any signs of lubricant leaking from the gearbox or brake housing.
 - Make sure the breather plug is clean, open, and installed correctly.
 - Make sure the winch outboard bearing is lubricated properly.
 - Make sure all labels and plates are readable, firmly attached, free of damage and clean. Replacements are available from the factory.
- DRAIN A SMALL AMOUNT OF OIL** into a clean container.
 - Check the oil for dirt, metal particles, water, and other signs of contamination. Completely drain the gearbox if oil is contaminated.
 - Make sure the gearbox and brake are properly lubricated. See Section 3.3 Lubricating the Winch.
- INSPECT THE WIRE ROPE** according to the wire rope manufacture's recommendations, or follow accepted industry standards for wire rope inspection.
 - Always wear protective clothing when handling wire rope.
 - Check the entire length of wire rope for bent wires, crushed areas, broken or cut wires, corrosion, and other damage. Carefully inspect areas that pass over sheaves or through roller guides.
 - Note the location and concentration of broken wires. Replace wire rope if more than 6 wires are broken in one lay, or more than 3 wires are broken in one strand in one lay. See Figure 16.
 - Make sure hooks and other fittings are securely attached to the wire rope, and the wire rope where they are attached is not frayed, corroded, broken, or otherwise damaged.
 - Make sure any hook latches open without binding and close when released.
 - Check the anchor holes in the drum and the surrounding area for signs of wear or distortion.
- MOVE THE DRUM** with your hands. Check for excessive movement indicating worn or loose gears, bearings, or shafts. Slight endplay in the driveshaft is normal. Excessive movement is caused by overloading or overheating, and is a sign that your application may require a larger winch.

- e INSPECT THE FOUNDATION AND RIGGING
 - Check mounting fasteners for stripped threads, wear, and other damage.
 - Check the foundation for cracks, corrosion, and other damage.
 - Make sure clew guide wires are snug and properly installed.
- f TEST WINCH PERFORMANCE by operating the winch with a load equal to the load rating.
 - Listen for unusual noises, and look for signs of damage as you operate the winch.
 - Make sure the wire rope winds evenly and tightly onto the drum. If it is loose or uneven, rewind it before continuing.
 - Observe the rotating drum; look for signs of loose or misaligned bearings.
 - Make sure the load moves smoothly, without hesitation or strain.
 - Make sure the handle rotates freely in both directions for manual winch models.
 - Check the brake. Raise the load, then lower it and stop it a few feet off the ground. If the load continues to coast or creep, the brake may be in need of repair or adjustment. See Section 3.2 Adjusting the Brake.
- g DISCONNECT POWER and inspect power supply equipment.
 - Check supply lines for wear, cuts, corroded connections, and other damage.
 - Check control devices and other power supply components for signs of moisture, corrosion, burn marks, cracks, and other damage.
- h CONNECT POWER.
 - Check power supply at motor and make sure it agrees with the motor rating.
 - Make sure the winch responds to the control device for motorized winch models. It must rotate as shown on the control labels, and it must turn off when you release the control.

Completely correct all problems before continuing. Use the troubleshooting chart to help determine the cause of certain problems. See Table 4.

Table 3 – Inspection Checklist

checked boxes indicate damage or problem in need of repair

	damages	problems
general	<input type="checkbox"/> finish weathered, flaking, otherwise damaged <input type="checkbox"/> parts cracked, bent, rusted, worn, otherwise damaged	<input type="checkbox"/> winch jerks or hesitates during operation <input type="checkbox"/> unusual noises, other signs of malfunction
brake housing	<input type="checkbox"/> lubricant leakage	<input type="checkbox"/> not properly lubricated <input type="checkbox"/> lubricant contaminated
fasteners	<input type="checkbox"/> stripped threads, bent, worn, otherwise damaged	<input type="checkbox"/> loose, not tightened to the proper torque
gearbox	<input type="checkbox"/> gears, bearings, or shafts loose, worn, otherwise damaged <input type="checkbox"/> lubricant leakage	<input type="checkbox"/> not properly lubricated <input type="checkbox"/> lubricant contaminated
drum	<input type="checkbox"/> anchor worn, distorted, otherwise damaged	<input type="checkbox"/> excessive movement or backlash
motor	<input type="checkbox"/> motor burnt out, otherwise damaged	<input type="checkbox"/> voltage at motor low
brake	<input type="checkbox"/> brake worn, corroded, otherwise damaged	<input type="checkbox"/> brake does not operate properly
rotary limit switch	<input type="checkbox"/> chain drive worn, corroded, otherwise damaged	<input type="checkbox"/> poor alignment or loose
control device	<input type="checkbox"/> electric components corroded, burnt, otherwise damaged	<input type="checkbox"/> fails to control hoist properly
electric circuit	<input type="checkbox"/> electric wires worn, cut, corroded, otherwise damaged <input type="checkbox"/> connections loose, corroded, otherwise damaged	<input type="checkbox"/> wires unprotected, obstructing traffic voltage at motor =
wire rope	<input type="checkbox"/> bent, crushed, otherwise damaged <input type="checkbox"/> broken wires, see Figure 16 replace if more than 6 wires in one lay, or 3 wires in one strand in one lay, are broken <input type="checkbox"/> diameter reduced, see Figure 17 replace if diameter is excessively worn	<input type="checkbox"/> wire rope loosely or unevenly wound number per strand = number per lay = diameter =
end connections	<input type="checkbox"/> corroded, rusted, worn, otherwise damaged	<input type="checkbox"/> not securely attached
labels and plates	<input type="checkbox"/> dirty, illegible, otherwise damaged	<input type="checkbox"/> loosely attached or missing

comments

authorized signature _____ date _____

Table 4 – Troubleshooting Chart

Contact the factory for detailed instructions on re-sealing the gearbox if you are required to disassemble the gearbox for any reason. Disassembly of the gearbox before contacting Thern, Inc. voids all warranties.

problem	cause	correction
handle turns, drum doesn't turn	<ul style="list-style-type: none"> • loose or broken spring pins or shafts inspect winch and brake, repair as necessary • loose, stripped or broken gears or keys repair as necessary 	
handle turns hard or not at all or motor tries to turn but can't	<ul style="list-style-type: none"> • unit overheated allow to cool • load too heavy lighten load • gearbox contaminated with dirt or debris inspect and relubricate as necessary • keys or spring pins loose or broken inspect winch and brake, repair as necessary • brake band too tight loosen brake and readjust • brake broken or locked inspect and repair as necessary • gears or bearings broken or locked inspect and replace as necessary 	
motor won't run	<ul style="list-style-type: none"> • circuit breaker tripped or fuse blown reset circuit breaker or replace fuse • poor power supply inspect and repair as necessary • power supply lines loose or damaged inspect, repair and tighten as necessary • power supply failure check power supply source • motor burnt out or damaged repair or replace as necessary 	
motor runs, drum doesn't turn	<ul style="list-style-type: none"> • loose or broken groove pin or keys inspect and replace as necessary • loose, stripped or broken gears inspect and replace as necessary 	
mechanical brake does not operate properly	<ul style="list-style-type: none"> • wire rope installed improperly reinstall wire rope correctly • brake adjusted incorrectly adjust brake • brake worn or damaged inspect and replace as necessary • brake components broken or locked inspect and repair as necessary 	
motor brake does not operate properly	<ul style="list-style-type: none"> • brake release lever in release position move to lock position • voltage to brake incorrect check voltage at control box, repair as needed • brake adjusted incorrectly contact factory • brake discs or solenoid worn or damaged inspect and replace as necessary • brake components seized up or damaged inspect and repair as necessary 	
excessive end play on drive shaft	<ul style="list-style-type: none"> • loose or damaged keys or keyways inspect and replace as necessary • thrust washer or bearing worn out inspect and replace as necessary • excessively worn gears inspect and repair as necessary 	
excessively worn gears or bearings	<ul style="list-style-type: none"> • load too heavy lighten load • poor lubrication of gears or bearings inspect and lubricate as necessary 	
overheating	<ul style="list-style-type: none"> • operated too long without rest allow to cool • load too heavy lighten load • poor lubrication inspect and lubricate as necessary • breather plug clogged or damaged clean or replace vent plug as needed • bearing seized up inspect and replace as necessary 	

Table 4 – Troubleshooting Chart *continued*

Contact the factory for detailed instructions on re-sealing the gearbox if you are required to disassemble the gearbox for any reason. Disassembly of the gearbox before contacting Thern, Inc. voids all warranties.

problem	cause	correction
unusual noises		
whining motor	• load too heavy.....	lighten load
	• motor overheated.....	allow to cool
knocking noise	• motor bearings burnt out.....	replace motor or bearings
	• mechanical brake needs adjustment	adjust mechanical brake
	• loose or worn parts on input shaft.....	contact factory
high pitched squeak	• poor lubrication	inspect and lubricate as necessary
grinding noise	• contaminated lubrication	drain, clean and lubricate the winch
	• dirt in winch gears	inspect and clean as necessary
	• broken gears or bearings	inspect and replace as necessary
rattling noise	• loose fasteners or set screws	tighten all fasteners and screws
heavy thump during operation	• contaminants in lubricant	drain, clean and lubricate the winch
	• loose set screws or keys in gears or shafts	inspect and repair as necessary
	• bearings defective.....	inspect and replace as necessary
back drive	• brake out of adjustment	adjust brake per manual

CW11 and CW25 Series Performance Characteristics¹

	CW11-2M	CW25-2M	CW11-2P	CW25-2P
Working Load Limit - 1st Layer	1100 lbs ²	2500 lbs ³	1100 lbs	2500 lbs
Working Load Limit - at 40 ft ⁴	970 lbs ²	2500 lbs ³	970 lbs	2500 lbs
Gear Ratio	32:1	31:1	160:1	232.50:1
Number of Haul Lines	2	2	2	2
Line Speed	-	-	13 fpm	11 fpm
Wire Rope (Groove) Size	1/4 in	5/16 in	1/4 in	5/16 in
Maximum Travel ⁴	40 ft	40 ft	40 ft	40 ft
D:d Ratio	18.6	18.5	18.6	18.5
Typical Handle Effort	26 lb	37 lb	-	-
Motor HP	-	-	1.3 - 1.5	1.5
Mechanical Brake	STANDARD	STANDARD	STANDARD	STANDARD
Design Factor	8:1	8:1	8:1	8:1
Weight	73 lbs	155 lbs	125 lbs	223 lbs

¹ Performance Characteristics are for standard products referred to in this manual. Non-standard products may vary from the original design. Contact Thern, Inc. for information.
² Load ratings for manual clew based on operation with drill rated for 10 amps at 250 rpm or 350 rpm.
³ Load ratings for manual clew are 1500 lb if operated with a drill rated for 10 amps at 250 rpm and 1200 lb if operated with a drill rated for 10 amps at 350 rpm.
⁴ Greater travel distance is possible with reduced load ratings. Contact the factory.

3.5 Repairing the Winch

Important!

- It is your responsibility to determine when to replace parts. When considering whether to continue using a part or to replace it, remember that replacing it is the best way to avoid further equipment damage.
- Replace spring pins, retaining rings, and oil seals whenever the winch is disassembled for inspection or repair.
- During reassembly, use **Loctite 598 Ultra Black** to seal the gearbox. Contact the factory for detailed instructions. Disassembly of the gearbox before contacting Thern, Inc. voids all warranties.
- Appoint a qualified person to be responsible for all repairs to the equipment.

- 3.6.1 GET FACTORY AUTHORIZATION for all repairs. Unauthorized repairs will void the warranty, and may lead to damage or failure of the winch.
- 3.6.2 REPLACE DAMAGED OR POORLY OPERATING PARTS with Thern repair parts.
- 3.6.3 REFINISH AREAS where the paint is worn or flaking. A good finish helps to protect against corrosion and environmental damage.
 - a REMOVE THE FINISH from damaged areas, down to the bare metal.
 - b CLEAN THE AREA thoroughly.
 - c REPAINT with a high quality primer and finishing coat.
- 3.6.4 TO ORDER REPAIR PARTS, contact your local dealer. Include the following information when ordering:
 - model number
 - **serial number** (or code number)
 - part number
 - date purchased, and from whom
 - description of what happened, or what is wrong
 - your name and return address

4.1 Transporting the Winch

Important!

- Keep a record of what you ship, and when you send it.

- 4.1.1 REMOVE THE BREATHER PLUG and install a sealed oil plug to prevent the loss of lubrication during shipment.
- 4.1.2 PACK THE WINCH in an upright position for transport, using the original packaging materials, if possible.
 - a FASTEN THE WINCH to a wooden base using lag bolts, to keep it from moving during transport.
 - b SEAL THE WINCH in plastic with a desiccant to help protect it from rust, corrosion, and other damage.
 - c CONSTRUCT WOODEN SIDES and top to enclose the winch in a solid protective crate.
 - d PACK LOOSE PARTS in small boxes or ship separately.
- 4.1.3 INSPECT THE WINCH according to the Instructions for Periodic Inspection before installing it in a new location.

4.2 Storing the Winch

- 4.2.1 LUBRICATE THE WINCH as necessary, and make sure the breather plug is clean and properly installed. Add a rust preventative for long term storage.
- 4.2.2 SEAL THE WINCH in plastic with a desiccant to help protect it from rust, corrosion, and other damage.
- 4.2.3 STORE THE WINCH upright, in a cool clean place away from corrosive chemicals and moisture.
- 4.2.4 ROTATE THE DRUM PERIODICALLY to keep bearing and gear surfaces from becoming lacquered.
- 4.2.5 INSPECT THE WINCH according to the Instructions for Periodic Inspection before installing it for operation.
- 4.2.6 LUBRICATE THE WINCH PROPERLY prior to operation. See section 3.3 Lubricating the Winch.

CW11-M Series Clew Winches

item	description	part number	qty.
1	REDUCER ASSEMBLY	D2611	1
2	PLUG BREATHER .375-18NPT X .48 PLN STL	A3408	1
3	FRAME WELDMENT	D2612	1
4	HEX NUT .375-16NC ZNPL GR2	A3017	6
5	SETSCREW SOKHD NYLK .312-18NC X .500 BLK OX ALYS	A3746	1
6	GROOVED DRUM WELDMENT	SEE TABLE	1
7	CROSS BRACE	B4278	1
8	COLLAR SHAFT 2PC .750ID X 1.500OD X .50	A8110	2
9	CLEW GUIDE PLATE	A9693	2
10	CAPSCREW SOKHD .375-16NC X 1.000 ALYSTL	A3445	2
11	WASHER HELSPRLK .375 X .683 X .094 ZNPL	A2926	2
12	CAPSCREW HEXHD .375-16NC X 1.250 ZNPL GR5	A3112	2
13	BRG FLNG 1.062 2 BOLT	A7285	1
14	LOCKING PIN PLATE	A8209	1
15	LOCKING PIN PLATE WELDMENT	A8208	1
16	HEX INPUT ASSEMBLY	B3705	1
17	KEY .188 X .188 X 1.000 4140HT OER	A7310	1
18	HANDLE MEDALLION ASSEMBLY	B4218	1
19	KEY .250 X .250 X 1.250 4140HT BES	A5477	2
20	LABEL WARNING DO NOT ADJUST BRAKE UNDER LOAD	A2658	1
21	LABEL NAMEPLATE CLEW WINCH SST	A8195	1
22	LABEL WARNING INSTALL WIRE ROPE AS SHOWN	A10843	1
23	LABEL WARNING KEEP HANDS AWAY FROM DRUM	A2659	1
24	LABEL WARNING READ FOR POWER WINCHES	SA5756	1
25	LABEL THERN STAGE EQUIPMENT	A10126	1
26	LABEL WARNING INSTALL WIRE ROPE AS SHOWN	A10844	1

CW11 Series Drums

Model	Item 6 Drum
CW11-1M	C4570
CW11-2M	SC6063

Model CW11-2M

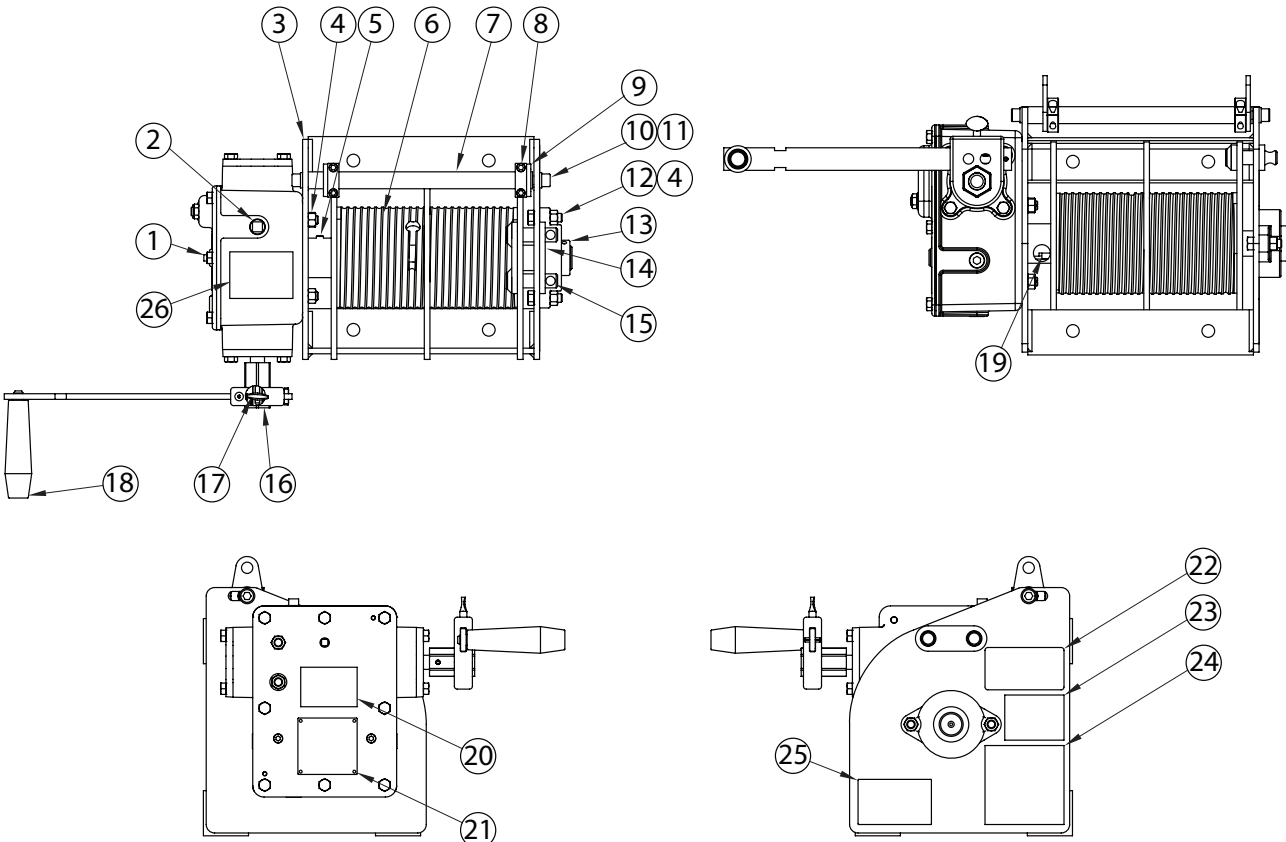

CW11 Series Reducer Assembly		D2611	
item	description	part number	qty.
1	CAPSCREW HEXHD .312-18NC X .750 ZNPL GR5	A3032	8
2	BEARING HOUSING ASSEMBLY	B3582	1
3	BRAKE DRUM SPACER	A2642	2
4	BRG THRUST .628ID X 1.250OD X .125 BRZ	A7291	1
5	BRAKE DRUM ASSEMBLY	B1700	1
6	WASHER FLT .656ID X 1.875OD X .094	A7292	2
7	SHIM .626/.630 X 1.00 X .018/.022 STL	A3308	1
8	PLUG PIPE SQHD .125-27NPT X .35 PLN STL	A3407	1
9	PIN DOWEL .188 X .500 ALYSTL	A7308	2
10	BRG BALL THRUST .753ID X 1.685OD X .625	A1498	1
11	BEARING HOUSING ASSEMBLY	B3581	1
12	CAPSCR HEXHD .312-18NC X 1.000 ZNPL GR5	A3028	8
13	WORM SHAFT	C3276	1
14	PLUG PIPE HEXSOC .125-27NPT X .31 SAE	A3405	2
15	BRAKE BAND CONNECTOR	B2917	1
16	NUT HEX JAM NYLK .375-16NC ZNPL GR2	A3180	2
17	COVER MACHINING	D2052	1
18	GEARCASE MACHINING	D2051	1
19	STUD .375-16NC X 1.312 GR5	A7279	4
20	DRUM SHAFT ASSEMBLY	D2610	1
21	OIL SEAL 1.125ID X 1.874OD X .250 NITRIL	A7287	1
22	PIPE PLUG HEXSOC .375-18NPT X .425 SAE	A3290	4
23	SPRING WASHER .380 X .750 X .034 SPR ST	A3296	1

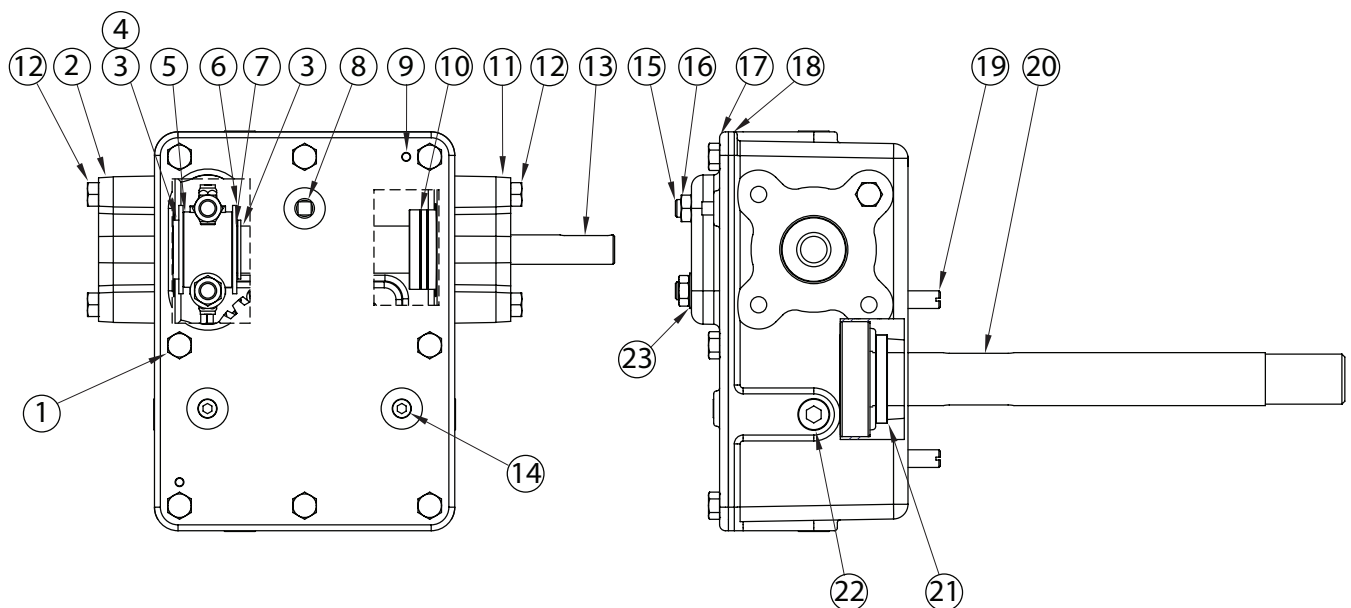

CW11 Series Handle Medallion Assembly		B4218	
item	description	part number	qty.
1	HANDLE ASSEMBLY	B4187	1
2	THUMB SCREW .312-18NC X .750 SST	A8167	1
3	MEDALLION MACHINING STL	B4189	1
4	SLOTTED SPRING PIN .187 X .750 SST	A4282	1

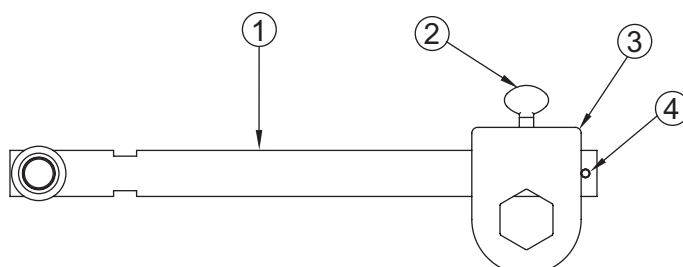

CW25-M Series Clew Winch			
item	description	part number	qty.
1	PLUG PIPE HEXSOC .375-18NPT X .425 SAE	A3290	12
2	BRAKE HOUSING MACHINING	D3257	1
3	MACHINING COVER BRAKE	C4450	1
4	CAPSCR HEXHD .375-16NC X 1.000 ZNPL GR5	A2922	12
5	BRG RAD BALL .750ID X 1.625OD X.31W STL	A9793	4
6	BRG RAD BALL 1.000 X 2.000 X .375	A2056	1
7	INPUT SHAFT	B4872	1
8	THRUST BEARING	A9604	3
9	BRG CLTUCH 1.000ID X 1.312OD X 1.063 STL	A9644	1
10	BRAKE DRUM	B4995	1
11	CAPSCREW HEXHD .312-18NC X .750 ZNPL GR5	A3032	4
12	BRAKE BAND ASSEMBLY	B4991	1
13	PIN DOWELL .250 X 2.000 ALYSTL	A9645	2
14	CONNECTOR BUSHING	A9612	2
15	NUT HEX NYLK .500-13NC ZNPL GR2	A2897	2
16	BRAKE BAND CONNECTOR	A9803	2
17	PLUG BREATHER .375-18NPT X .48 PLN STL	A3406	1
18	BRG BALL THRUST .753ID X 1.685OD X .625	A1498	2
19	WORM SPACER	A9564	2
20	WORM 1.750D X 1.500PD X 1.22RD 2 LEAD	A1612	1
21	KEY .188 X .188 X 2.000 4140 HT BER	A3255	1
22	GEARCASE MACHINING	D3244	1
23	SHIM .760/.786 X 1.235/1.265 X .018/.024	A4389	2
24	SEAL OIL .750ID X 1.375OD X .250	A9518	1
25	END CAP	B4866	1
26	HANDLE ASSEMBLY	B5275	1
27	HANDLE SOCKET	A10122	1
28	PIN SLOTTED SPRING .250 X 1.500 STL	A4499	1
29	WORM GEAR 8.12OD X 7.750PD X 7.469RD	C4401	1
30	KEY .500 X .500 X 1.000 4140 HT BES	A10120	2
31	DRUM SHAFT	D3452	1
32	BRG RAD BALL 45MM X 85MM X 19MM	A9968	2
33	FRONT COVER MACHINING	C4378	1
34	SHIM 1.883 X 2.750 X .060 STL	A10124	2
35	SEAL OIL 1.625ID X 2.252 X .313	A9967	1
36	BACK COVER MACHINING	C4377	1
37	CAPSCR HEXHD .375-16NC X 1.500 ZNPL GR5	A3236	4
38	FRAME WELDMENT	D3451	1
39	SETSCR SOKHD NYLK .375-16NC X .625 BLKOX	A3128	1
40	BRG FLNG 1.44ID 4 BOLT SETSCR LOCK	A10429	1
41	CAPSCR HEXHD .438-14NC X 1.500 ZNPL GR5	A2895	4
42	NUT HEX NYLK .438-14NC ZNPL GR2	A2896	4
43	DRUM WELDMENT	SEE TABLE	1
44	CLEW MOUNTING SHAFT	B5255	1
45	CLEW GUIDE PLATE	A9693	2
46	COLLAR SHAFT 2PC .750ID X 1.500OD X .50	A8110	2
47	WASHER FLT .375 X .750 X .125 SST	A1907	1
48	WASHER SPLK INT .375 X .692 X .035 SST	A3939	1
49	CAPSCR SOKHD .375-16NC X 1.000 X ZNPL ALYS	A3445	1
50	PIN LOCKING PLATE	A8063	1
51	WELDMENT PIN LOCKING PLATE	B4205	1
52	O-RING .375 X .500 X.063 NITRILE	A9614	2
53	KEY .375 X .375 X 2.000	A4129	2
54	O-RING .750 X .875 X.063 NITRILE	A9613	4
55	WASHER SPRING .559 X 1.100N X .039 SPR STL	A9646	2
56	LABEL NAMEPLATE CLEW WINCH SST	A8195	1
57	LABEL WARNING READ FOR POWER WINCHES	A5756	1
58	LABEL WARNING KEEP HANDS AWAY FROM DRUM	A2659	1
59	LABEL WARNING DO NOT ADJUST BRAKE WITH WINCH UNDER LOAD	A2658	1
60	LABEL WARNING INSTALL WIRE ROPE AS SHOWN	A10843	1
61	LABEL THERN STAGE EQUIPMENT	A10126	1
62	LABEL WARNING INSTALL WIRE ROPE AS SHOWN	A10844	1

CW25 Series Drums

Model Item 46 Drum

CW25-1M	C4713
CW25-2M	C4667

Model CW25-2M

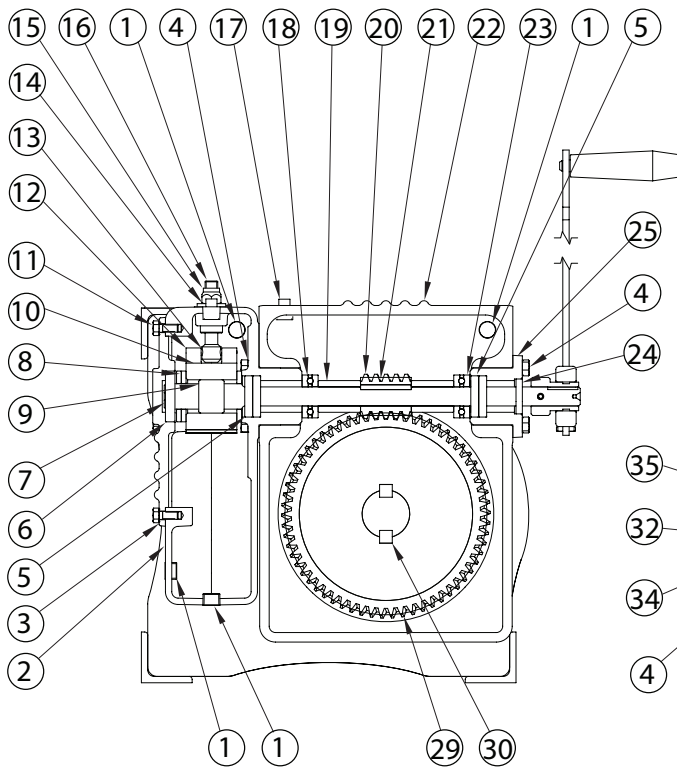

SECTION A-A

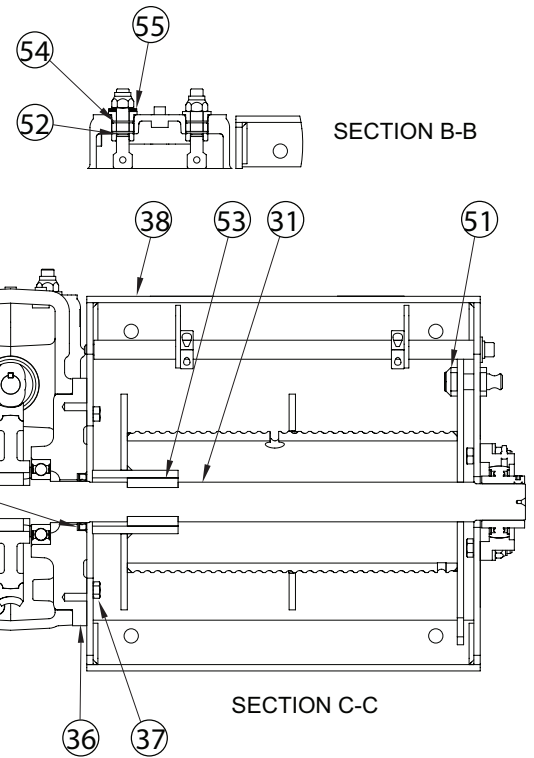

SECTION C-C

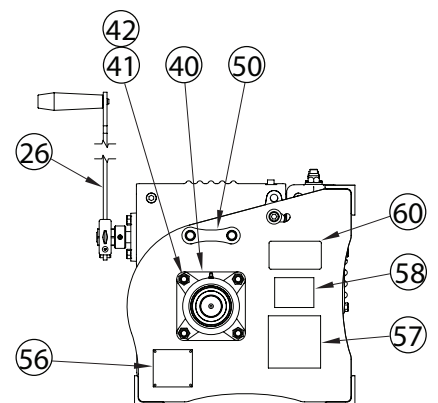
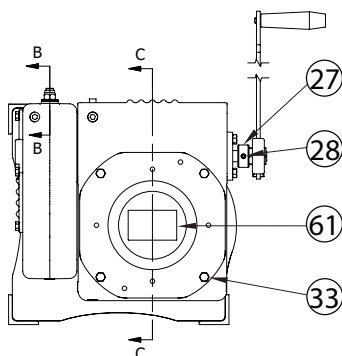
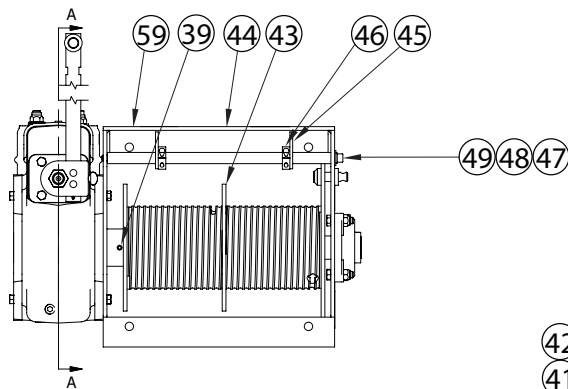
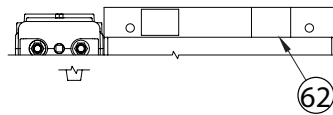

Model CW11-P Series

item	description	part number	qty.
1	MOTOR	SEE TABLE	1
2	KEY .188 X .188 X 1.500 4140 HT BER	A4576	1
3	CAPSCR HEXHD .375-16NC X 1.000 ZNPL GR5	A2922	4
4	REDUCER NMRV040 5:1 56C .625 BORE	B3750	1
5	KEY .188 X .188 X 1.000 4140HT OER	A7310	1
6	BRACKET ROTARY LIMIT SWITCH 8PC1 SERIES	C4520	1
7	PIN SLOTTED SPRING .187 X 1.250 STL	A2849	1
8	SPROCKET MACH 25 20TH M12ID X .187 PIN	A9665	1
9	NUT HEX .375-16NC ZNPL GR2	A3017	6
10	SPROCKET MACH 25 40TH 1.75ID X .312 PIN	A9597	1
11	ROLLCHAIN 25 X .25P 88 PITCHES	A9666	1
12	ROLLCHAIN CONLINK 25 X .25P SPRGCLP	A9604	1
13	SETSCR SOKHD NYLK .312-18NC X .750	A3133	1
14	CROSS BRACE	B4278	1
15	COLLAR SHAFT 2PC .750ID X 1.500OD X .50	A8110	2
16	FRAME WELDMENT	D2612	1
17	CAPSCR SOKHD .375-16NC X 1.000 ALYSTL	A3445	2
18	WASHER HELSPRLK .375 X .683 X .094 ZNPL	A2926	2
19	GROOVED DRUM WELDMENT	SEE TABLE	1
20	CAPSCR HEXHD .375-16NC X 1.250 ZNPL GR5	A3112	2
21	BRG FLNG 1.062 2 BOLT	A7285	1
22	PLUG TAPERED EXPANSION .750 DIA ZNPL STL	A3754	2
23	REDUCER ASSEMBLY	D2611	1
24	KEY .250 X .250 X 1.250 4140 HT BES	A5477	2
25	CAPSCR FLGHD .250-20NC X .500 ZNPL	A9668	2
26	MACHSCR RNDHDSL 10-24NC X 1.750 ZNPL	A8199	1
27	NUT HEX 10-24NC ZNPL GR2	A3569	2
28	SWITCH ROTARY LIMIT 75:1 GF4C 4-POLE	B4940	1
29	NUT HEX NYLK 10-24NC ZNPL GR2	A3315	2
30	CARIGBOLT 10-24NC X .625 ZNPL	A9669	2
31	WASHER FLT SAE #10 X .500 X .049 ZNPL	A1059	2
32	PLUG BREATHER .375-18NPT X .48 PLN STL	A3408	1
33	CHAIN GUARD 8PC1 SERIES	C4521	1
34	CLEW GUIDE PLATE	A9693	2
35	LABEL WARNING INSTALL WIRE ROPE AS SHOWN	A10843	1
36	LABEL WARNING KEEP HANDS AWAY FROM DRUM	A2659	1
37	LABEL WARNING READ FOR POWER WINCHES	SA5756	1
38	LABEL THERN STAGE EQUIPMENT	A10126	1
39	LABEL WARNING DO NOT MANUALLY RELEASE BRAKE	A2481	1
40	LABEL WARNING DISCONNECT ELECTRIC POWER	A2256	1
41	LABEL WARNING DO NOT ADJUST BRAKE WITH WINCH UNDER	A2658	1
42	LABEL NAMEPLATE POWER WINCHES	A9556	1
43	LABEL WARNING INSTALL WIRE ROPE AS SHOWN	A10844	1

Model	Lines	Rope Dia. (in)	Item 1 Motor	Item 19 Drum	Voltage	Weight (lbs)
CW11-2PA	2	.25	B4954	SC6036	115, 1 Ph	124
CW11-2PC	2	.25	B5177	SC6036	208, 3 Ph	124
CW11-2PD	2	.25	B4935	SC6036	230/460, 3 Ph	124
CW11-1PA	1	.31	B4954	C4570	115, 1 Ph	120
CW11-1PC	1	.31	B5177	C4570	208, 3 Ph	120
CW11-1PD	1	.31	B4935	C4570	230/460, 3 Ph	120

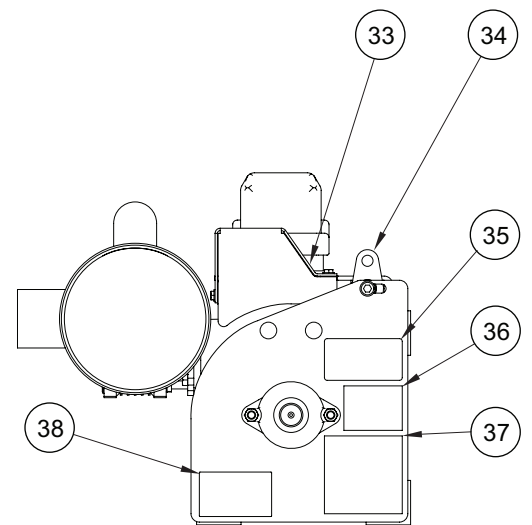
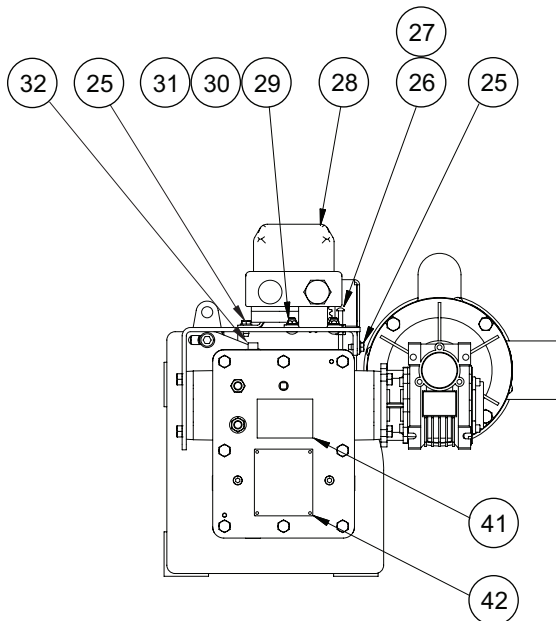
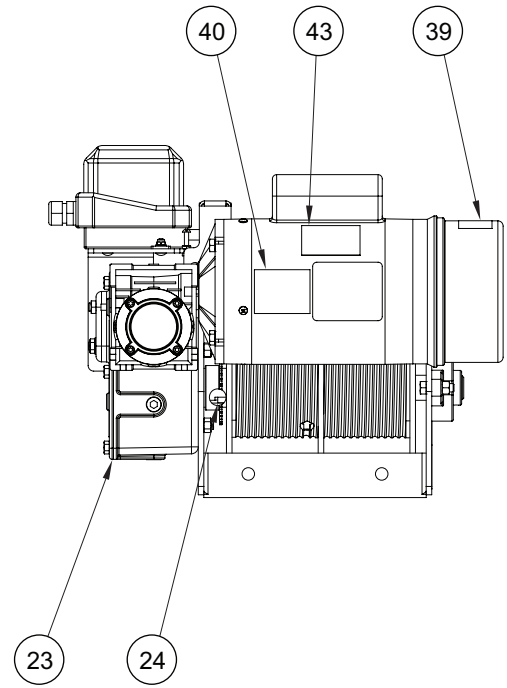
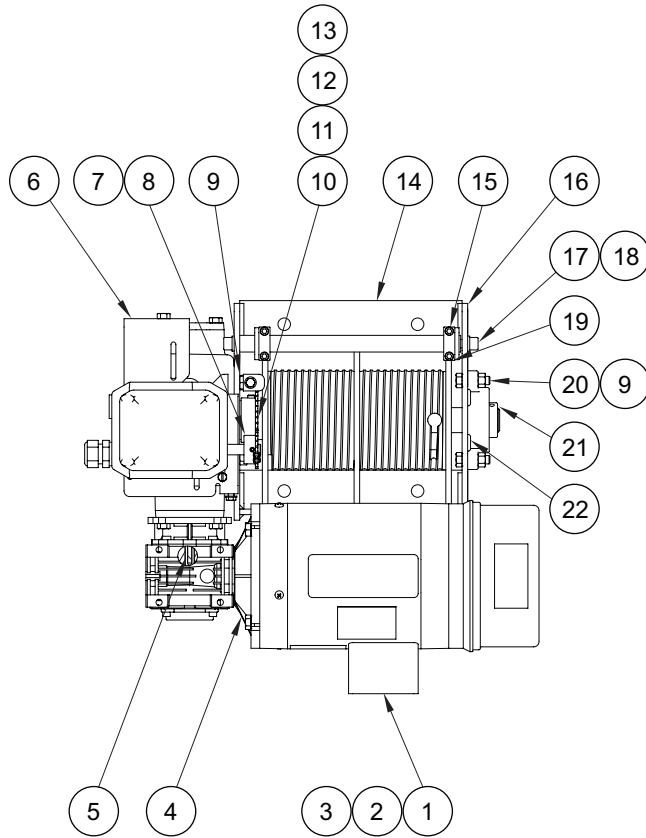

Model CW25-P Series			
item	description	part number	qty.
1	PLUG PIPE HEXSOC .375-18NPT X .425 SAE	A3290	12
2	BRAKE HOUSING MACHINING	D3257	1
3	MACHINING COVER BRAKE	C4450	1
4	CAPSCR HEXHD .375-16NC X 1.000 ZNPL GR5	A2922	16
5	BRG RAD BALL .750ID X 1.625OD X .31W STL	A9793	4
6	BRG RAD BALL 1.000 X 2.000 X .375	A2056	1
7	INPUT SHAFT	B4872	1
8	THRUST BEARING	A9804	3
9	BRG CLUTCH 1.000ID X 1.312OD X 1.063 STL	A9844	1
10	BRAKE DRUM	B4995	1
11	CAPSCR HEXHD .312-18NC X .750 ZNPL GR5	A3032	4
12	BRAKE BAND ASSEMBLY	B4991	1
13	PIN DOWEL .250 X 2.000 ALYSTL	A9845	1
14	CONNECTOR BUSHING	A9812	1
15	NUT HEX NYLK .500-13NC ZNPL GR2	A2897	6
16	BRAKE BAND CONNECTOR	A9803	2
17	PLUG BREATHER .375-18NPT X .48 PLN STL	A3408	1
18	BRG BALL THRUST .753ID X 1.685OD X .625	A1498	2
19	WORM SPACER	A9564	2
20	WORM 1.75OD X 1.500PD X 1.22RD 2 LEAD	A1612	1
21	KEY .188 X .188 X 2.000 4140 HT BER	A3255	1
22	GEARCASE MACHINING	D3244	1
23	SHIM .760/.786 X 1.235/1.265 X .018/.024	A4389	2
24	SEAL OIL .750ID X 1.375OD X .250	A9518	1
25	CAPSCR SOKHD .375-16NC X 1.000 ZNPL ALYS	A3445	5
26	MOTOR	SEE TABLE	1
27	KEY .188 X .188 X 1.375 4140 HT BES	A5178	1
28	WASHER HELSPRLK .375 X .683 X .094 ZNPL	A2926	9
29	COVER PROTECTIVE FOR NORD SK1SI63	A10102	1
30	REDUCER SK1SI63 7.5:1 140TC	B4877	1
31	KEY .375 X .375 X 1.500 4140 HT BER	A3253	1
32	KEY .188 X .188 X 1.000 4140HT OER	A7310	1
33	REDUCER ADAPTER	B5087	1
34	REDUCER MOUNT	C4381	1
35	KEY .500 X .500 X 1.000 4140 HT BES	A10120	2
36	WORM GEAR 8.12OD X 7.750PD X 7.469RD	C4401	1
37	DRUM SHAFT	D3452	1
38	BRG RAD BALL 45MM X 85MM X 19MM	A9968	2
39	FRONT COVER MACHINING	C4378	1
40	SHIM 1.883 X 2.750 X .060 STL	A10124	2
41	SEAL OIL 1.625ID X 2.252 X .313	A9967	1
42	BACK COVER MACHINING	C4377	1
43	SETSCR SOKHD .375-16NC X 1.00 BLKOX ALYS	A10778	1
44	FRAME WELDMENT	D3451	1
45	PLUG TAPERED EXPANSION .750 DIA ZNPL STL	A3754	2
46	BRG FLNG 1.44ID 4 BOLT SETSCR LOCK	A10429	1
47	DRUM WELDMENT	SEE TABLE	1
48	CAPSCR HEXHD .500-13NC X 2.000 ZNPL GR5	A2894	4
49	CAPSCR HEXHD .375-16NC X 1.500 ZNPL GR5	A3236	4
50	CLEW MOUNTING SHAFT	B5255	1
51	CLEW GUIDE PLATE	A9693	2
52	COLLAR SHAFT 2PC .750ID X 1.500OD X .50	A8810	2
53	WASHER FLT .375 X .750 X .125 SST	A1907	3
54	O-RING .375 X .500 X .063 NITRILE	A9814	2
55	KEY .375 X .375 X 2.000	A4129	2
56	O-RING .750 X .875 X .063 NITRILE	A9813	4
57	WASHER SPRING .559 X 1.100 X .039 SPR STL	A9846	2
58	RLS MOUNTING BRACKET	C4709	1
59	SWITCH ROTARY LIMIT 75:1 GF4C 4-POLE	B4940	1
60	CARIGBOLT 10-24NC X .625 ZNPL	A9669	2
61	NUT HEX NYLK 10-24NC ZNPL GR2	A3315	2
62	WASHER FLT SAE #10 X .500 X .049 ZNPL	A1059	2
63	CHAIN GUARD	C4710	1
64	SPROCKET MACH 40 24TH 2.55ID X .375 PIN	A10733	1
65	SPROCKET MACH 40 10TH M12ID X .187 PIN	A9659	1
66	ROLLCHAIN CONLINK 40 X .50P SPRGCLP	A1590	1
67	ROLLCHAIN 40 X .50P 46 PITCHES	A9176	1
68	MACHSCR RNDHDSL 10-24NC X .375 ZNPL STL	A3879	2
69	PIN SLOTTED SPRING .187 X 1.250 STL	A2849	1
70	CAPSCR HEXHD .375-16NC X 1.250 ZNPL GR5	A3112	1

Model CW25-P Series (continued)

item	description	part number	qty.
71	LABEL NAMEPLATE POWER WINCHES	A9556	1
72	LABEL WARNING DISCONNECT ELECTRIC POWER	A2256	1
73	LABEL WARNING DO NOT MANUALLY RELEASE BRAKE	A2481	1
74	LABEL WARNING READ FOR POWER WINCHES	SA5756	1
75	LABEL WARNING KEEP HANDS AWAY FROM DRUM	A2659	1
76	LABEL WARNING DO NOT ADJUST BRAKE WITH WINCH UNDER	A2658	1
77	LABEL WARNING INSTALL WIRE ROPE AS SHOWN	A10843	1
78	LABEL THERN STAGE EQUIPMENT	A10126	1
79	LABEL WARNING INSTALL WIRE ROPE AS SHOWN	A10844	1

Model	Lines	Rope Dia. (in)	Item 26 Motor	Item 47 Drum	Voltage (3 Phase)	Weight (lbs)
CW25-2PC	2	.31	B5179	C4667	208	223
CW25-2PD	2	.31	B5218	C4667	230/460	223
CW25-1PC	1	.375	B5179	C4713	208	225
CW25-1PD	1	.375	B5218	C4713	230/460	225

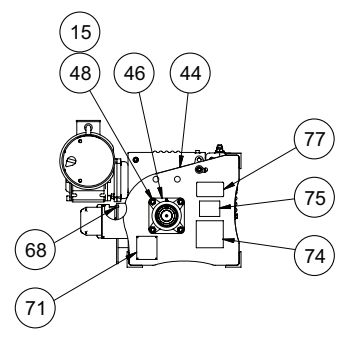
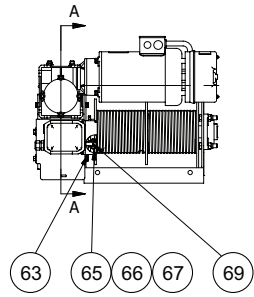
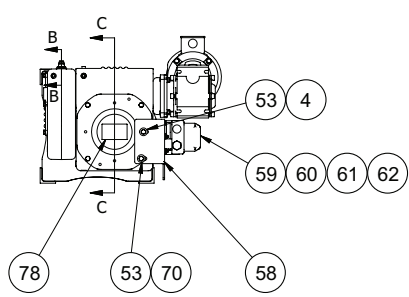
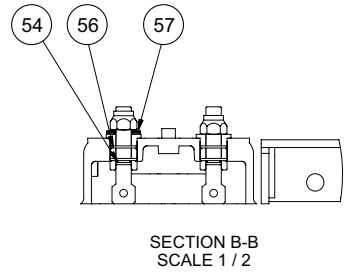
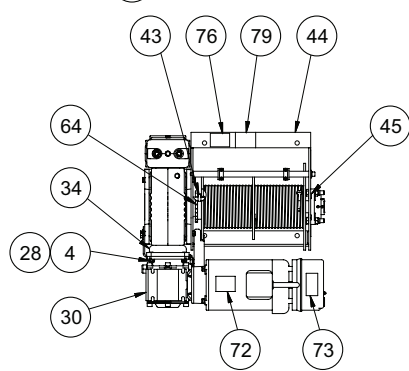
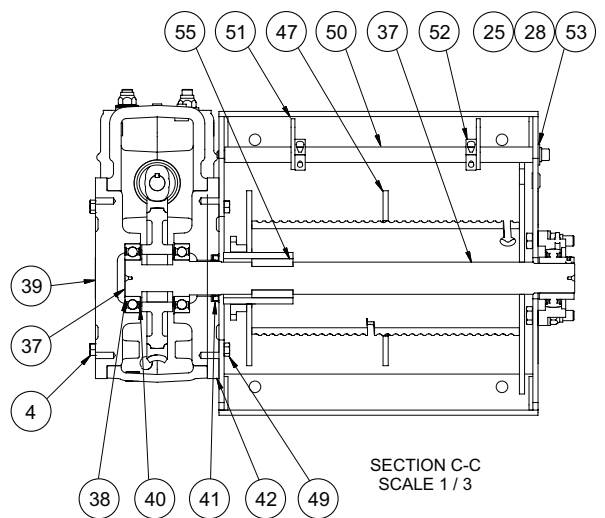
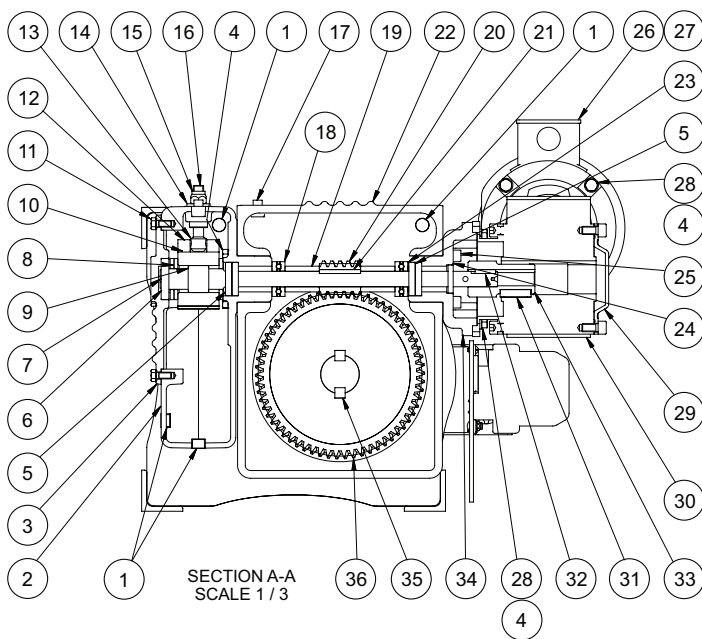



Thern Stage Equipment
5712 Industrial Park Road
Winona, MN 55987

PHN 800-553-2204
FAX 507-454-5282

EMAIL: info@thernstage.com
www.thernstage.com