



Read this Owner's Manual thoroughly before operating the equipment. Keep it with the equipment at all times. Replacements are available from Thern Stage Equipment, 5712 Industrial Park Rd., Winona, MN 55987, 507-454-2996. www.thernstage.com

IMPORTANT: Please record product information on page 2. This information is required when calling the factory for service.



Owner's Manual

For PW Series Pilewind Power Hoists

Two-Year Limited Warranty

Please record the following:

Date Purchased: _____

Model No.: _____

Serial No.: _____

This information is required when calling the factory for service.

Thern, Inc. warrants its products against defects in material or workmanship for two years from the date of purchase by the original using buyer, or if this date cannot be established, the date the product was sold by Thern, Inc. to the dealer. To make a claim under this warranty, contact the factory for an RGA number. The product must be returned, prepaid, directly to Thern, Inc., 5712 Industrial Park Road, Winona, Minnesota 55987. The following information must accompany the product: the RGA number, the date of purchase, the description of the claimed defect, and a complete explanation of the circumstances involved. If the product is found to be defective, it will be repaired or replaced free of charge, and Thern, Inc. will reimburse the shipping cost within the contiguous USA.

This warranty does not cover any damage due to accident, misuse, abuse, or negligence. Any alteration, repair or modification of the product outside the Thern, Inc. factory shall void this warranty. This warranty does not cover any costs for removal of our product, downtime, or any other incidental or consequential costs or damages resulting from the claimed defects. This warranty does not cover brake discs, wire rope or other wear components, as their life is subject to use conditions which vary between applications.

FACTORY AUTHORIZED REPAIR OR REPLACEMENT AS PROVIDED UNDER THIS WARRANTY IS THE EXCLUSIVE REMEDY TO THE CONSUMER. THERN, INC. SHALL NOT BE LIABLE FOR ANY INCIDENTAL OR CONSEQUENTIAL DAMAGES FOR BREACH OF ANY EXPRESS OR IMPLIED WARRANTY ON THIS PRODUCT. EXCEPT TO THE EXTENT PROHIBITED BY APPLICABLE LAW, ANY IMPLIED WARRANTY OF MERCHANTABILITY OR FITNESS FOR A PARTICULAR PURPOSE ON THIS PRODUCT IS LIMITED IN DURATION TO THE DURATION OF THIS WARRANTY.

Some states do not allow the exclusion or limitation of incidental or consequential damages, or allow limitations on how long an implied warranty lasts, so the above limitation or exclusion may not apply to you. This warranty gives you specific legal rights, and you may also have other rights which vary from state to state.

Note: Thern, Inc. reserves the right to change the design or discontinue the production of any product without prior notice.

About This Manual

The Occupational Safety and Health Act of 1970 states that it is the employer's responsibility to provide a workplace free of hazard. To this end, all equipment should be installed, operated, and maintained in compliance with applicable trade, industrial, federal, state, and local regulations. It is the equipment owner's responsibility to obtain copies of these regulations and to determine the suitability of the equipment to its intended use.

This Owner's Manual, and warning labels attached to the equipment, are to serve as guidelines for hazard-free installation, operation, and maintenance. They should not be understood to prepare you for every possible situation.

Information contained in this Owner's Manual is applicable only to the Thern PW Series Power Hoist. Do not use this manual as a source of information for any other equipment.

The following symbols are used for emphasis throughout this manual:

▲WARNING

Failure to follow 'WARNING!' instructions may result in equipment damage, property damage, and/or serious personal injury.

▲CAUTION

Failure to follow 'CAUTION!' instructions may result in equipment damage, property damage, and/or minor personal injury.

Important!

Failure to follow 'Important!' instructions may result in poor performance of the equipment.

Suggestions for Safe Operation

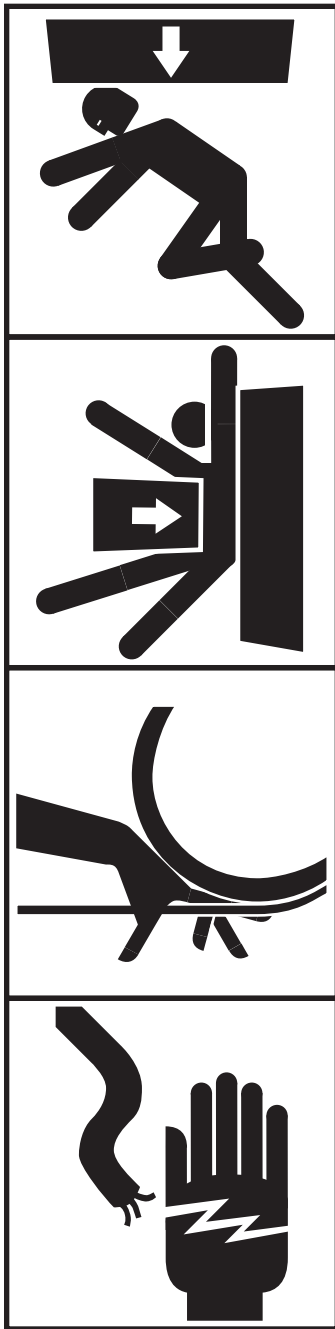

⚠️WARNING

DO the following:

Read and comply with the guidelines set forth in this Owner's Manual. Keep this manual, and all labels attached to the hoist, readable and with the equipment at all times. Contact Thern, Inc. for replacements.

Check lubrication before use.

Install the wire rope securely to the hoist drum.

Keep at least 4 wraps of wire rope wound on the drum at all times, to serve as anchor wraps. With less than 4 wraps on the drum the wire rope could come loose, causing the load to escape.

Keep hands away from the drum, gears, wire rope, and other moving parts of the equipment.

Keep all unnecessary personnel away from hoist while in operation. Keep out of the path of the load and out of the path of a broken wire rope that might snap back and cause injury.

Disconnect electric power before servicing the equipment.

DO NOT do the following:

This product is designed for lifting and moving material only. Do not use this product for any other purpose.

Do not exceed the load rating of the hoist or any other component in the system. To do so could result in failure of the equipment.

Do not use more than one hoist to move a load unless each hoist was designed for use in a multiple hoist system.

Do not use damaged or malfunctioning equipment. To do so could result in failure of the equipment.

Do not modify the equipment in any way. To do so could cause equipment failure.

Do not wrap the wire rope around the load. This damages the wire rope and could cause the load to escape. Use approved rigging connections to secure the wire rope to the load.

Do not operate the hoist with drive guards or gear covers removed or improperly installed.

Do not divert your attention from the operation. Stay alert to the possibility of accidents, and try to prevent them from happening.

Do not jerk or swing the load. Avoid shock loads by starting and stopping the load smoothly. Shock loads overload the equipment and may cause damage.

Do not adjust the brake with the hoist holding a load. Accidental release of the brake could result in loss of the load.

1.1 Installing the Hoist

Important!

- Inspect the hoist immediately following installation according to the Instructions for Periodic Inspection. This will give you a record of the condition of the hoist with which to compare future inspections.
- A qualified professional should inspect or design the foundation to insure that it will provide adequate support.
- When positioning the hoist use the lifting holes provided or a sling wrapped around drum.
- Do not attempt to lift or position hoist by using any part of the reducer or motor.
- Do not weld the hoist frame to the foundation or support structure. Welding the frame may void warranty, contact TSE. Use fasteners as instructed.

⚠WARNING

Do not install the hoist in an area defined as hazardous by the National Electric Code, unless installation in such an area has been thoroughly approved.

Do not install the hoist near corrosive chemicals, flammable materials, explosives, or other elements that may damage the hoist or injure the operator. Adequately protect the hoist and the operator from such elements.

Position the hoist so the operator can stand clear of the load, and out of the path of a broken wire rope that could snap back and cause injury.

Attach the hoist to a rigid and level foundation that will support the hoist and its load under all load conditions, including shock loading.

- 1.1.1 CONSULT APPLICABLE CODES AND REGULATIONS for specific rules on installing the equipment.
- 1.1.2 LOCATE THE HOIST in an area clear of traffic and other obstacles. Make sure the hoist is accessible for maintenance and operation.
- 1.1.3 LOCATE THE HOIST in an area with adequate temperatures. Check the motor and reducer manufacturer's information for ambient temperature ratings.
- 1.1.4 POSITION THE HOIST to allow access for proper lubrication.
- 1.1.5 INSTALL THE HOIST on a level surface. The hoist is designed and assembled for horizontal base mounting. **Special consideration must be taken if mounting underhung (motor vertical) or underhung (motor horizontal). Please contact TSE.**
- 1.1.6 THE HOIST MUST BE ALIGNED WITH THE HEAD OR LEAD BLOCK to ensure proper spooling of wire rope and correct operation. See Figure 1.
- 1.1.7 FASTEN THE HOIST SECURELY to the foundation.
 - a For Standard products referred to in this manual, use coarse thread fasteners, grade 5 or better. Be sure to check the torque required for your fastener selection before mounting hoist. Make sure the hoist is secured to a solid foundation able to support the hoist and the load under all conditions with design factors based on accepted engineering practices.
 - b Non-standard products that vary from the original design may have different fastening requirements. Contact a structural engineer or Thern, Inc. for this information.

CONTACT A QUALIFIED PROFESSIONAL FOR MOUNTING INSTRUCTIONS TO COMPLY WITH LOCAL CODES.

1.2 Installing the Breather Plug

Important!

- Save the sealed plug for use when the hoist is removed for storage or transport.

CAUTION

Install the breather plug to vent heat and pressure. Failure to do so could result in pressure buildup which could damage the reducer.

For shipment, the reducer is filled with lubricant and breather plugs shipped loose. Install the breather plugs before operation. Refer to the reducer manufacturer's instructions.

1.2.1 INSPECT VENT PLUG often to ensure it is clean and operating.

1.2.2 CHECK THE LUBRICANT LEVEL in the reducer to make sure no lubricant was lost during shipment. Lubricant level varies with installation orientation. Refer to the reducer manufacturer's instructions.

Important!

- Use a head or lead block to direct the wire rope to the drum whenever possible.
- Install sheaves, tracks and other equipment so they will remain fixed under all load conditions. Follow the recommendations of the equipment manufacturer.
- Use sheaves of proper diameter to minimize wear on the wire rope. Follow the recommendations of the sheave manufacturer.

Figure 1 – Minimizing the Fleet Angle

The hoist and head or lead block must be properly aligned when installed to ensure proper spooling of wire rope and correct operation.

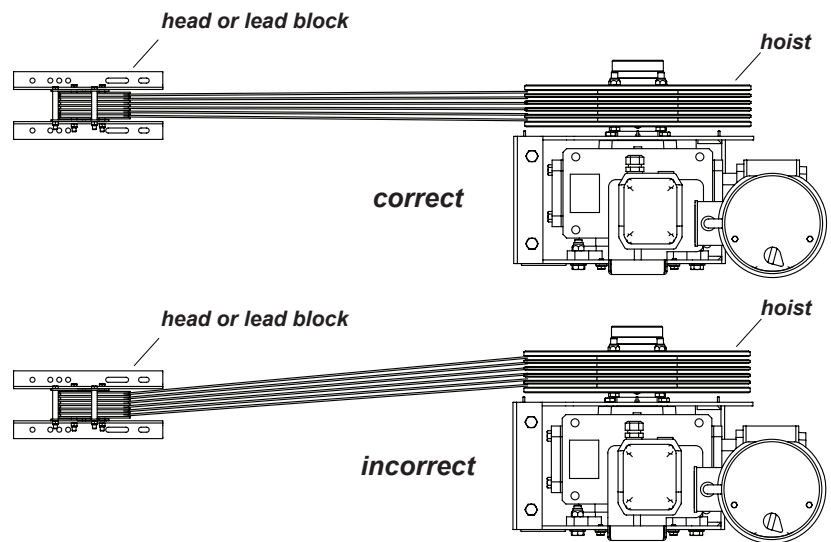

1.3 Connecting Electric Power

Important!

- Use electrical equipment with the correct rating and Underwriter's Laboratory (UL) approval.
- Always disconnect electric current when the hoist is not in use.

⚠ WARNING

Install proper branch circuits, disconnect devices, protection, and grounding as required by article 430 of the National Electric Code.

All electrical work must be performed by a licensed electrician. Failure to do so could result in electric shock or poor hoist operation.

All control devices must be momentary contact type. Install all control devices so the hoist motor will stop when the operator releases the device.

Locate control devices so the operator will be able to view the load through the entire operation.

Locate control devices so the operator will be clear of the load, the wire rope, and the path of a broken wire rope that could snap back and cause injury.

It is the responsibility of the owner to provide equipment for controlling the hoist. Electrical control packages are available from TSE. The following guidelines are supplied as a reference for the installer.

- 1.3.1 CONSULT APPLICABLE CODES AND REGULATIONS for specific rules on electrical installation.
- 1.3.2 CHECK THE COMPONENT MANUFACTURER'S INSTRUCTIONS for installing and connecting the motor, brake, and other equipment.
- 1.3.3 INSTALL A FUSE or circuit breaker in the power supply circuit, as required by the National Electric Code.
- 1.3.4 INSTALL A DISCONNECT DEVICE in the power supply circuit, as required by the National Electric Code. This should be a switch you can lock in the OFF position to prevent unauthorized use of the hoist.
- 1.3.5 CONNECT ELECTRIC STARTER CONTROLS to the motor. **Make sure the load brake is wired for fast braking on brakemotors that offer this function.** Check the component manufacturer's information.
- 1.3.6 CONNECT ELECTRIC POWER SUPPLY, with ground wire, to the electric starter control box. Check the component manufacturer's information for a wiring diagram.
- 1.3.7 CONNECT OTHER ELECTRIC EQUIPMENT to the proper terminals in the electric control box.
- 1.3.8 CHECK THE CURRENT at the motor and make sure it agrees with the current rating marked on the hoist nameplate. If current rating is incorrect, have the circuit inspected by a licensed electrician.
- 1.3.9 TEST ELECTRICAL CONNECTIONS by operating the hoist.
 - a ROTATION OF THE DRUM must agree with the labels on the control device, either UP and DOWN, or FORWARD and REVERSE.
 - b CHECK THE LOAD BRAKE, make sure it releases when the motor is ON, and engages when the motor is OFF. **Make sure the fast brake function operates correctly on brakemotors that include this feature.**

CONTACT THE FACTORY OR A QUALIFIED PROFESSIONAL FOR HELP.

1.4 Installing the Wire Rope

Important!

- Use wire rope and other rigging equipment rated for the size of the largest load you will be moving.
- Do not drag the wire rope through dirt or debris that could cause damage, or poor operation.
- Always wear protective clothing when handling wire rope.

⚠WARNING

Install the wire rope securely to the hoist drum. A poorly secured wire rope could come loose from its anchor and allow the load to escape.

- 1.4.1 DETERMINE WHICH DIRECTION the drum must rotate to wind and unwind wire rope.
- 1.4.2 REPOSITION WIRE ROPE ANCHOR PLATE as required to ensure all lines wrap at the same diameter. This is especially important when lines exit the drum at different locations.
- 1.4.3 PURCHASE THE PROPER WIRE ROPE for your application. Keep the following in mind when selecting a wire rope. Contact a reputable wire rope supplier for help.
 - a BREAKING STRENGTH of new wire rope should be at least 8 times greater than the load placed on the wire rope. These are minimum values and will vary with the type of load and how you are moving it.
 - b WE RECOMMEND 7 x 19 galvanized aircraft cable for diameters up to 5/16 inch.
- 1.4.4 ANCHOR THE WIRE ROPE to the drum using standard compression stop sleeves or cable with swaged ball ends.

NOTE: Use standard stop sleeves or swaged ball ends to retain first wire rope layer.

- a FOR CABLE INSTALLATION. See Figure 2.
 - REMOVE shaft bolt and end cap.
 - LOOSEN THE DRUM PLATE BOLTS and separate the flanges such that the cable with end stops can be slid into place.
 - LOOSEN shaft end cap bolt.
 - RE-TIGHTEN drum plate bolts and re-install shaft end cap and bolt.
 - CHECK AND CORRECT for any gaps between drum sections or pinched cable.
- 1.4.5 WIND FOUR FULL WRAPS of wire rope onto the drum by operating the hoist while holding the wire rope taught. **These wraps serve as anchor wraps and must remain on the drum at all times. This can be verified through windows on the drum flange.**

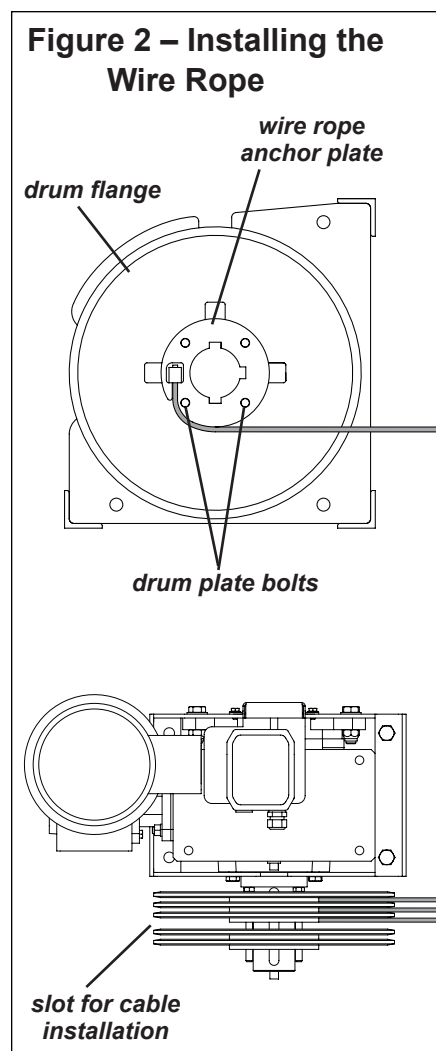

1.5 Setting Travel Limits

⚠ CAUTION

Limit set points are dependant on speed of operation. Use caution with setting limits on units with variable speed operation. Typically, limits should be for the highest speed to be encountered.

Correct setup may take some trials and adjustments.

Standard units are shipped with TER limit switches. For units equipped with other limit switches, refer to manufacturer's instructions.

Each unit's travel is controlled by two sets of limit switches driven from the gear box output shaft. One set controls the normal movement (travel limit) of the unit. The other set (absolute limit) are there to indicate an overtravel in the event of a failure to the travel limits.

The absolute limits should be set first to determine the absolute maximum range of travel that the unit is able to run securely. The travel limits should be set within this range to limit the movement of the normal operating range.

1.5.1 SET LIMITS by doing the following. **Absolute limits should be set before travel limits. Refer to manufacturer's instructions. See Figure 3.**

- a REMOVE the limit switch cover.
- b LOOSEN the large locking screw in the center of the column. Individual limits can now be set.
- c DETERMINE WHICH DIRECTION the limit switch cam rotates when the "UP" button is pressed.
- d TURN THE SCREW labeled "1" so that the microswitch is hit by the cam when the load "opens" to the desired position. The lower limit "4" should be adjusted so that the microswitch is hit by the cam as the unit moves into position in the "DOWN" direction.
- e REPEAT THE PROCESS with screws labeled "2" and "3" to set the normal operating travel limits.
- f AFTER SETTING BOTH LIMITS the locking screw can be tightened and the limits re-checked.
- g REPLACE the cover.

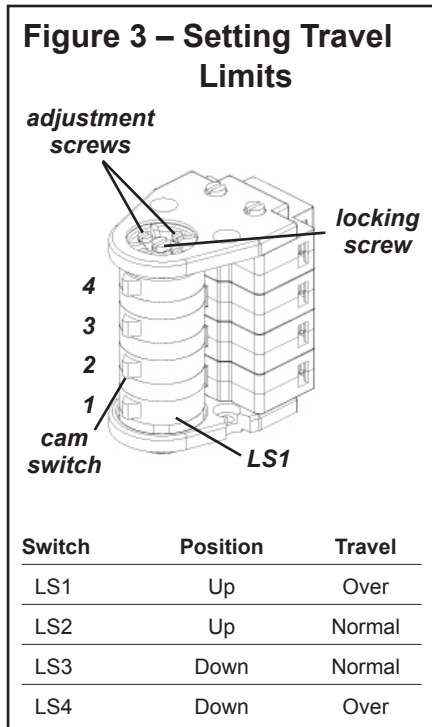

2.1 General Theory of Operation

Important!

- Limit nonuniform winding by keeping tension on the wire rope.
- To help insure rated performance, make sure voltage at the motor is equal to the motor's voltage rating.
- It is your responsibility to detect and account for different factors affecting the condition and performance of the equipment.

⚠WARNING

Do not depend on hoist gearing to hold the load in place. A brake must be used.

Avoid shock loads, and do not exceed the load rating of the equipment.

- 2.1.1 THE FORCE REQUIRED to move the load must not exceed the load rating of the hoist. Consider the total force required to move the load, not the weight of the load.
- 2.1.2 THIS EQUIPMENT CAN develop forces that will exceed the load rating. It is the responsibility of the equipment user to limit the size of the load. Inspect the equipment regularly for damage according to the instructions contained in this manual and in the component manufacturer's information.
- 2.1.3 BRAKES are included to provide positive load holding for lifting. Although a new worm gear hoist may appear to hold the load in place, this characteristic will diminish with use.
- 2.1.4 PERFORMANCE RATINGS of the equipment are affected by the amount of wire rope wound on the drum, the way in which it is wound, and the way the hoist is used.
- a DRUM CAPACITY depends on how tightly and evenly the wire rope is wound on the drum. Actual drum capacities can be less than values shown in performance tables.
- b LINE SPEED increases with each additional layer of wire rope wound onto the drum. The weight of the load does not affect line speed.
- c LOAD RATING represents the maximum force that can be placed on new equipment. Load ratings are assigned values for specific amounts of load travel or wire rope accumulation.
- 2.1.5 DUTY RATINGS refer to the type of use the equipment is subject to. Consider the following when determining duty rating.
- a ENVIRONMENT: harsh environments include hot, cold, dirty, wet, corrosive, or explosive surroundings. **Protect the equipment from harsh environments when possible.**
- b MAINTENANCE: poor maintenance, meaning poor cleaning, lubrication, or inspection, leads to poor operation and possible damage of the equipment. **Minimize poor maintenance by carefully following the instructions contained in this manual.**
- c LOADING: severe loading includes shock loading and moving loads that exceed the load rating of the equipment.
- d FREQUENCY OF OPERATION: frequent start and stop functions increase wear and shorten the life span of the gear train and load brake components. Lengthy operations cause lubrication to become hot, which also decreases the life span of the gear train. **Increase maintenance of the equipment if used in frequent operations.**

CONTACT THE FACTORY FOR MORE INFORMATION.

2.2 Breaking-In the Hoist

- 2.2.1 BREAK-IN OCCURS typically during the first few hours of normal operation. During break-in, mating surfaces become polished, and clearances increase. This is desired for efficient operation of bearings and gears.
- 2.2.2 INSPECT THE HOIST following break-in according to the Instructions for Periodic Inspection. See section 3.3 Inspecting the Equipment.

2.3 Preparing for Operation

Important!

- When determining whether the load will exceed the load rating, consider the total force required to move the load.

⚠WARNING

Read and comply with the guidelines set forth in this Owner's Manual. Keep this manual, and all labels attached to the hoist, readable and with the equipment at all times. Contact Thern, Inc. for replacements.

This product is designed for lifting and moving material only. Do not use this product for any other purpose.

Do not exceed the load rating of the hoist or any other component in the system. To do so could result in failure of the equipment.

Do not use more than one hoist to move a load unless each hoist was designed for use in a multiple hoist system.

Do not use damaged or malfunctioning equipment. To do so could result in failure of the equipment.

Do not modify the equipment in any way. To do so could cause equipment failure.

Do not operate the hoist with drive guards or gear covers removed or improperly installed.

Check lubrication before use.

- 2.3.1 CONSIDER THE OPERATION. Do not begin until you are sure you can perform the entire operation without hazard.
- 2.3.2 BEFORE EACH OPERATION inspect all components of the system.
- OPERATORS must be in good health, alert, thoroughly trained in operating the equipment, and properly clothed (safety equipment as required, no loose clothing, no loose jewelry).
 - THE LOAD must be clear of other objects and free to move. Make sure the load will not tip, bind, or in any way move uncontrollably.
- 2.3.3 KNOW YOUR LOAD and make sure you do not exceed the load rating of the hoist or any other equipment in the system.

2.4 Moving the Load

Important!

- Obey a stop signal from anyone.
- Maintain tension on the wire rope to keep it tightly and evenly wound on the drum.
- If the hoist and load are not visible during the entire operation, get help from another person.
- Appoint a supervisor if more than one person is involved in the operation. This will reduce confusion and increase safety.

⚠WARNING

Keep at least 4 wraps of wire rope wound on the drum at all times, to serve as anchor wraps. With less than 4 wraps on the drum the wire rope could come loose, causing the load to escape.

Keep all unnecessary personnel away from hoist while in operation. Keep out of the path of the load and out of the path of a broken wire rope that might snap back and cause injury.

Keep hands away from the drum, gears, wire rope, and other moving parts of the equipment.

Do not divert your attention from the operation. Stay alert to the possibility of accidents, and try to prevent them from happening.

Do not jerk or swing the load. Avoid shock loads by starting and stopping the load smoothly. Shock loads overload the equipment and may cause damage.

2.4.1 MOVE THE LOAD slowly and smoothly, only a small distance at first. Make sure the load is balanced and securely attached before continuing.

2.4.2 USE THE CONTROL DEVICE to operate the hoist. The control device should be momentary contact type, so the hoist will stop when the operator releases the control.

2.4.3 OBSERVE THE WIRE ROPE as it winds onto the drum. If it jams or binds, stop the operation and rewind the wire rope before continuing. **Continued operation with uneven wire rope can damage the wire rope and shorten its life.**

2.4.4 OBSERVE THE REDUCER during operation for signs of overheating. **Frequent overheating may be a sign of damage, or may indicate the need for a larger power hoist.**

a WATCH FOR SMOKE, the smell of burnt lubricant, and other signs of overheating. Use a thermocouple or other device to monitor reducer temperature as necessary.

b STOP THE OPERATION if the reducer overheats, and allow the hoist to cool. **Continued operation may cause damage.**

Important!

Increase the frequency of maintenance procedures if the hoist is:

- Operated for long periods.
- Used to lift heavy loads.
- Operated in wet, dirty, hot, or cold surroundings.

3.1 Cleaning the Hoist

Clean the hoist to remove dirt and help prevent rust and corrosion.

3.1.1 CLEAN THE HOIST every six months or whenever it is dirty.

a WIPE ALL EQUIPMENT to remove dirt and grease.

b LEAVE A LIGHT FILM of oil on all surfaces to protect them against rust and corrosion.

c WIPE OFF excessive amounts of oil to avoid the accumulation of dirt.

3.1.2 REMOVE ALL UNNECESSARY OBJECTS from the area around the hoist.

3.2 Lubricating the Hoist

Important!

- Do not leave plug holes in the reducer open. Open plug holes will allow dirt and moisture to contaminate the lubrication.
- Make sure lubricant has a temperature rating appropriate for the ambient temperatures of the operation.
- Replace the motor bearings if the motor is disassembled for any reason.

⚠WARNING

Do not mix oil types. Reducers require high-grade lubricants of proper viscosity to maintain trouble-free performance. Some lubricants are not compatible with each other. Refer to reducer manufacturer's information, product labels, or contact the factory for assistance.

⚠CAUTION

Make sure the breather plug is clean and open to vent heat and pressure. Poor ventilation may cause overheating and result in damage to oil seals and other equipment.

Fill the speed reducer to the proper level without overfilling. Too much or too little lubricant will cause overheating and result in damage to seals, bearings, and gears.

Table 1 – Oil Capacity

Mount	Model	
	PW12	PW21
Upright Vertical		
Primary (P)	24 oz	48 oz
Secondary (S)	308 oz	320 oz
Underhung Vertical		
Primary (P)	24 oz	48 oz
Secondary (S)	152 oz	304 oz
Underhung Horizontal		
Primary (P)	28 oz	48 oz
Secondary (S)	128 oz	248 oz

Lubricate the hoist properly to help protect it from wear and rust. Read the following instructions carefully.

- 3.2.1 MOTOR BEARINGS are typically lubricated for life by the manufacturer. Some motors require periodic lubrication. Refer to the motor manufacturer's information for specific instructions.
- 3.2.2 LUBRICATE THE REDUCER according to the manufacturer's instructions. See Figure 4.
 - a CHECK OIL LEVEL monthly. Remove the level plug and make sure oil is even with the plug hole.
 - b FILL THE REDUCER according to the manufacturer's instructions. Fill the reducer until oil reaches the level plug. **Do not mix different lubricants.** See Table 1.
 - c CHANGE REDUCER LUBRICANT at least every 12 months depending on usage, or whenever it is dirty or contaminated.
- 3.2.3 LUBRICATE THE WIRE ROPE by following the wire rope manufacturer's recommendations.

Figure 4 – Oil Plugs

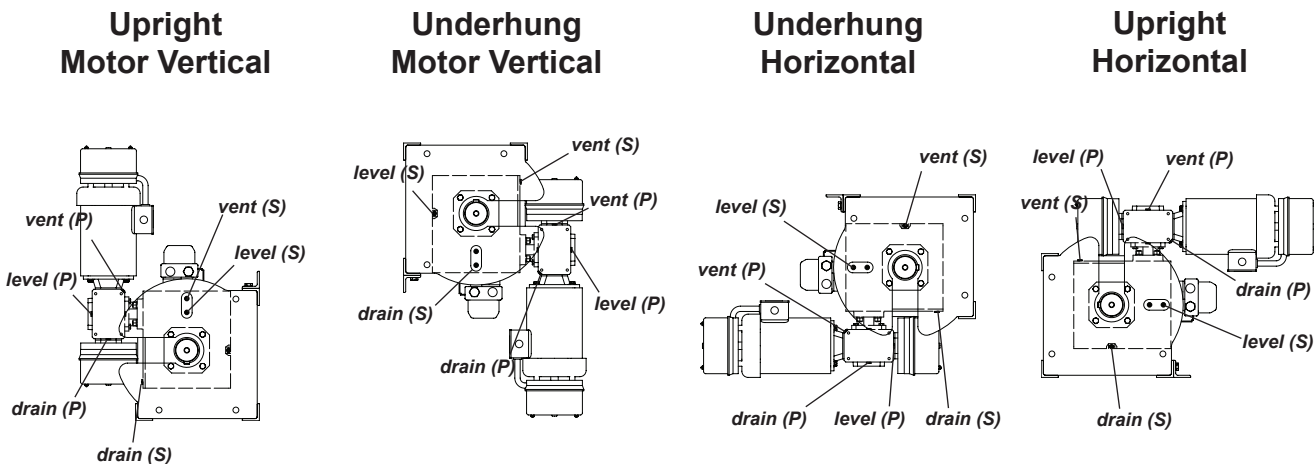

3.3 Inspecting the Equipment

Important!

- Start an inspection program as soon as you put the hoist into use.
- Appoint a qualified person to be responsible for regularly inspecting the equipment.
- Keep written records of inspection. This allows comparison with comments from previous inspections so you can see changes in condition or performance. See Table 2.

Perform frequent inspections:

- Monthly.
- Whenever you notice signs of damage or poor operation.

Frequent Wire Rope Inspection:

- Use ASME B30.7 as a guideline for rope inspection, replacement and maintenance.
- Check the wire rope, end connections and end fittings for corrosion, kinking, bending, crushing, bird-caging or other signs of damage.
- Check the number, distribution and type of visible broken wires. See paragraph 3.3.4 d and figure 5.
- Check the wire rope for reduction of rope diameter from loss of core support, or wear of outside wires. See figure 6.
- Take extra care when inspecting sections of rapid deterioration such as sections in contact with saddles, sheaves, repetitive pickup points, crossover points and end connections.

⚠WARNING

Do not use damaged or malfunctioning equipment. Place an “OUT OF ORDER” sign on the hoist. Do not use the hoist until the sign is removed by a qualified maintenance person who has completely corrected the problem.

Inspect the hoist to detect signs of damage or poor operation before they become hazardous. See Table 2 - Inspection Checklist.

3.3.1 CONSULT APPLICABLE CODES AND REGULATIONS for specific rules on inspecting the hoist and other equipment.

3.3.2 CHECK COMPONENT MANUFACTURER’S INSTRUCTIONS for inspecting the motor, brake, reducer, bearings, wire rope, and other equipment.

3.3.3 Instructions for Frequent Inspection

- a VISUALLY INSPECT the entire hoist and all other equipment involved in the operation.
 - Check all equipment for cracks, dents, bending, rust, wear, corrosion and other damage.
 - Make sure the wire rope is installed correctly and anchored securely to the drum.
 - Check the reducer for signs of leakage.
 - Make sure the entire hoist is properly lubricated.
 - Make sure the breather plug is clean, open, and installed correctly.
 - Make sure mounting fasteners are tightened securely.
 - Make sure the foundation is in good condition, and capable of supporting the hoist and its load under all load conditions.
 - Check electrical wiring and connections for wear, corrosion, cuts, and other damage.
- b TEST HOIST PERFORMANCE by operating the hoist with a load not exceeding the load rating.
 - Listen for unusual noises, and look for signs of damage as you operate the hoist.
 - Make sure the wire rope winds evenly and tightly onto the drum. If it is loose or jammed, rewind it before continuing.
 - Make sure the load moves smoothly, without hesitation or strain.
 - Make sure the hoist responds to the control device. It must rotate as shown on the control labels, and it must turn off when you release the control.
 - Check the brake. Raise the load, then lower it and stop it a few feet off the ground. If the load continues to coast or creep, the brake needs adjustment. Refer to brake manufacturer’s instructions.

Completely correct all problems before continuing. Use the Troubleshooting Chart to help determine the cause of certain problems. See Table 3.

Perform periodic inspections:

- Every 12 months.
- Whenever you return the hoist to service from storage.
- Whenever you notice damage or poor operation in a frequent inspection.
- Whenever you have, or think you may have, overloaded or shock loaded the hoist.

Figure 5 – Broken Wires

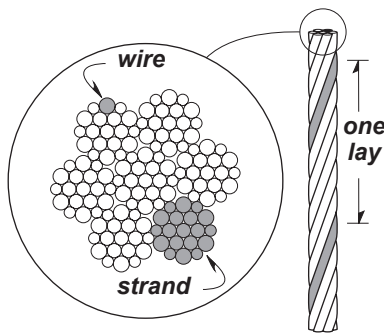

Wire rope assembly must be replaced if more than 6 wires are broken in one lay, or if more than 3 wires are broken in one strand in one lay.

Figure 6 – Rope Diameter

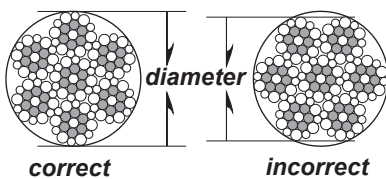

The wire rope assembly must be replaced if the diameter measures less than the minimum diameter at any point.

wire rope diameter	minimum diameter
up to 1/8 in	7/64 in (.1094 in)
up to 3/16 in	11/64 in (.1719 in)
up to 1/4 in	15/64 in (.2344 in)
up to 5/16 in	19/64 in (.2969 in)

3.3.4 Instructions for Periodic Inspection

- a VISUALLY INSPECT the hoist and all other equipment.
 - Check the finish for wear, flaking, or other damage.
 - Check all equipment for cracks, dents, bending, rust, wear, corrosion and other damage. If the equipment was overloaded, or if you notice cracks or other signs of overloading and damage promptly remove equipment from use and have it repaired or replaced. **DO NOT CONTINUE TO USE DAMAGED OR OVERLOADED EQUIPMENT OR WIRE ROPE.**
 - Check all fasteners for stripped threads, wear, bends, and other damage.
 - Check the gearbox for signs of leakage. Contact the factory if there are any signs of lubricant leaking from the gearbox.
 - Make sure the breather plug is clean, open and installed correctly.
 - Remove guards and visually inspect the rotary limit switch chain for poor alignment, excessive wear, corrosion, and other damage.
 - Make sure the entire hoist is properly lubricated.
 - Make sure all labels and plates are readable, firmly attached, free of damage and clean. Replacements are available from the factory.
- b INSPECT THE HOIST MOUNTING FOUNDATION.
 - Check mounting fasteners for stripped threads, wear, and other damage.
 - Check the foundation for cracks, corrosion, and other damage.
- c DRAIN A SMALL AMOUNT OF LUBRICANT from the reducer into a clean container.
 - Check the lubricant for dirt, metal particles, water, and other signs of contamination. Completely drain the reducer if lubricant is contaminated.
- d REMOVE THE WIRE ROPE entirely from the drum.
 - Always wear protective clothing when handling wire rope.
 - Check the entire length of wire rope for bent wires, crushed areas, broken or cut wires, corrosion, and other damage. Carefully inspect areas that pass over sheaves or through roller guides.
 - Note the location and concentration of broken wires. Replace wire rope if more than 6 wires are broken in one lay, or more than 3 wires are broken in one strand in one lay. See Figure 5.
 - Check the anchor holes in the drum and the surrounding area for signs of wear or distortion.
- e PLACE enough weight to keep the wire rope straight and tightly drawn.
 - Measure the diameter of the wire rope, especially in areas where wear is noticeable. Replace the wire rope if the diameter measures below the minimum diameter at any point. See Figure 6.

- f MOVE THE DRUM with your hands.
 - Check for excessive movement indicating worn or loose gears or bearings. Excessive movement is caused by overloading or overheating, and is a sign that your application may require a larger power hoist.
 - Disassemble the hoist if necessary. Inspect keys, bearings, seals, and shafts for wear, distortion, and other damage.
- g FILL THE REDUCER with lubricant, and lubricate the entire hoist.
- h INSTALL THE WIRE ROPE.
- i TEST HOIST PERFORMANCE by operating the hoist with a test load equal to the load rating.
 - Listen for unusual noises, and look for signs of damage as you operate the hoist.
 - Make sure the wire rope winds evenly and tightly onto the drum. If it is loose or jammed, rewind it before continuing.
 - Observe the rotating drum, look for signs of loose or misaligned bearings.
 - Make sure the hoist responds to the control device. It must rotate as shown on the control labels, and it must turn off when you release the control.
 - Make sure the load moves smoothly without hesitation or strain.
 - Check the brake. Raise the load, then lower it and stop it a few feet off the ground. If the load continues to coast or creep, the brake needs adjustment. Refer to brake manufacturer's instructions.
- j DISCONNECT ELECTRIC POWER and inspect electrical equipment.
 - Check electrical wires for worn insulation, cuts, corroded connections, and other damage.
 - Check voltage of electrical supply with a UL approved voltmeter. If voltage is low, have a licensed electrician inspect the circuit.
 - Make sure the electrical control box is securely installed. Look inside the control box for signs of moisture, corrosion, burn marks, cracks, and other damage.
- k CONNECT ELECTRIC POWER.

Completely correct all problems before continuing. Use the troubleshooting chart to help determine the cause of certain problems. See Table 3.

Table 3 – Troubleshooting Chart

Contact the factory for assembly/disassembly instructions. Disassembly of the gearbox before contacting Thern, Inc. voids all warranties.

problem	cause	correction
motor won't run	<ul style="list-style-type: none"> • circuit breaker tripped or fuse blown reset circuit breaker or replace fuse • electrical connections loose or damaged inspect, repair and tighten as necessary • electric power supply failure contact power company • motor burnt out or damaged repair or replace as necessary 	
motor runs, drum doesn't turn	<ul style="list-style-type: none"> • loose or broken gear keys inspect and replace as necessary • loose, stripped or broken gears inspect and replace as necessary 	
motor tries to turn but can't	<ul style="list-style-type: none"> • unit overheated allow to cool • load too heavy lighten load • voltage at motor too low inspect supply circuit and rewire as needed • electric brake not operating properly inspect and repair as necessary • gears or bearings broken or locked inspect and replace as necessary 	
brake does not operate properly	<ul style="list-style-type: none"> • brake release lever in release position move to lock position • voltage to brake incorrect check voltage at control box, repair as needed • brake adjusted incorrectly adjust brake • brake discs or solenoid worn or damaged inspect and replace as necessary • brake components seized up or damaged inspect and repair as necessary 	
lubricant leakage	<ul style="list-style-type: none"> • worn bearings inspect and replace as necessary • damaged oil seals or gaskets inspect and replace as necessary • cracked or damaged reducer inspect and repair as necessary 	
excessive end play on drive shaft	<ul style="list-style-type: none"> • loose or damaged retaining ring or spacers inspect and replace as necessary • excessively worn gears inspect and repair as necessary 	
excessive worn gears or bearings	<ul style="list-style-type: none"> • load too heavy lighten load • poor lubrication of reducer or bearings inspect and lubricate as necessary 	
overheating	<ul style="list-style-type: none"> • operated too long without rest allow to cool • load too heavy lighten load • poor lubrication inspect and lubricate as necessary • breather plug clogged or damaged clean or replace breather plug • bearing seized up inspect and replace as necessary 	
unusual noises		
high pitched squeak	<ul style="list-style-type: none"> • poor lubrication inspect and lubricate as necessary 	
grinding noise	<ul style="list-style-type: none"> • contaminated oil drain, clean and lubricate the hoist • broken gears or bearings inspect and replace as necessary 	
whining motor	<ul style="list-style-type: none"> • load too heavy lighten load • motor overheated allow to cool • motor bearings burnt out replace motor or bearings 	
rattling noise	<ul style="list-style-type: none"> • loose fasteners or sets crews tighten all bolts and screws • worn or loose drag brake inspect and repair or tighten as necessary 	
heavy thump during operation	<ul style="list-style-type: none"> • contaminants in lubricant drain, clean and lubricate the hoist • loose set screws or keys in gears or shafts inspect and repair as necessary • bearings defective inspect and replace as necessary 	

3.4 Repairing the Hoist

Important!

- It is your responsibility to determine when to replace parts. When considering whether to continue using a part or to replace it, remember that replacing it is the best way to avoid further equipment damage.
- Replace spring pins, retaining rings, and oil seals whenever the hoist is disassembled for inspection or repair.
- Appoint a qualified person to be responsible for all repairs to the equipment.

- 3.4.1 GET FACTORY AUTHORIZATION for all repairs. Unauthorized repairs will void the warranty, and may lead to damage or failure of the hoist.
- 3.4.2 REPLACE DAMAGED OR POORLY OPERATING PARTS with Thern repair parts.
- 3.4.3 REFINISH AREAS where the paint is worn or flaking. A good finish helps to protect against corrosion and weather damage.
 - a REMOVE THE FINISH from damaged areas, down to the bare metal.
 - b CLEAN THE AREA thoroughly.
 - c REPAINT with a high quality primer and finishing coat.
- 3.4.4 TO ORDER REPAIR PARTS, contact your local dealer. Include the following information when ordering:
 - model number
 - serial number (or code number)
 - part number
 - date purchased, and from whom
 - description of what happened, or what is wrong
 - your name and return address

4.1 Transporting the Hoist

Important!

- Keep a record of what you ship, and when you send it.

- 4.1.1 REMOVE THE BREATHER PLUG and install a sealed plug to prevent the loss of lubrication during shipment.
- 4.1.2 PACK THE HOIST in an upright position for transport, using the original packaging materials, if possible.
 - a FASTEN THE HOIST to a wooden base using bolts, to keep it from moving during transport.
 - b SEAL THE HOIST in plastic with a desiccant to help protect it from rust, corrosion, and other damage.
 - c CONSTRUCT WOODEN SIDES and top to enclose the hoist in a solid protective crate.
 - d PACK LOOSE PARTS in small boxes or ship separately.
- 4.1.3 INSPECT THE HOIST according to the Instructions for Periodic Inspection before installing it in a new location.

4.2 Storing the Hoist

- 4.2.1 FILL THE REDUCER with lubricant, and make sure the breather plug is clean and properly installed. Add a rust preventative for long term storage. Follow the reducer manufacturer's instructions.
- 4.2.2 SEAL THE HOIST in plastic with a desiccant to help protect it from rust, corrosion, and other damage.
- 4.2.3 STORE THE HOIST upright, in a cool clean place away from corrosive chemicals and moisture.
- 4.2.4 ROTATE THE DRUM PERIODICALLY to keep bearing and gears surfaces from becoming lacquered. Release the brake to rotate the drum.
- 4.2.5 INSPECT THE HOIST according to the Instructions for Periodic Inspection before installing it for operation.
- 4.2.6 TEST INSULATION RESISTANCE in the motor to detect moisture damage. Refer to the motor manufacturer's instructions.
- 4.2.7 DRAIN THE REDUCER and fill with proper lubricant prior to operation. See section 3.2 Lubricating the Hoist.

Model PW12 Pilewind Hoist			
item	description	part number	qty.
1	WELDMENT FRAME 8PW1	C4517	1
2	ANGLE FRAME 8PW1	B5017	1
3	CAPSCR HEXHD .500-13NC X 1.250 ZNPL GR5	A2928	2
4	NUT HEX NYLK .500-13NC ZNPL GR2	A2897	6
5(C)	REDUCER 250:1 WITH 200V BRAKE	B5180	1
5(D)	REDUCER 250:1 WITH 230/460V BRAKE	B5186	1
6	CAPSCR HEXHD .375-16NC X 1.000 ZNPL GR5	A2922	4
7	WASHER SPLK INT .375 X .692 X .035	A3939	4
8(C)	MOTOR BRK 1.5HP 1740 RPM 208/3/60	A5179	1
8(D)	MOTOR BRK 1.5HP 1740 RPM 230/460/3/60	A5218	1
9	KEY .188 X .188 X 1.500 4140 HT BER	A4576	1
10	CAPSCR HEXHD .500-13NC X 1.750 ZNPL GR5	A3164	4
11	WASHER FLT SAE .500 X 1.062 X .095 ZNPL	A2932	4
12	CAPSCR HEXHD .438-14NC X 1.000 GR5	A9782	4
13	SHAFT DRUM PW 2.187	SEE TABLE	1
14	KEY .500 X .500 X 2.500 4140 HT BER	A7847	2
15	KEY .625 X .625 X [] 4140 HT BER	SEE TABLE	1
16	RING RET EXT 2.156 SPRSTL	A9935	1
17	BRACKET RLS MOUNTING 8PW2	B5018	1
18	CAPSCR HEXHD .312-18NC X 0.750 ZNPL GR5	A3032	2
19	WASHER HELSPRLK .312 X .586 X .078 ZNPL	A2925	2
20	WASHER FLT SAE .312 X .688 X .065 ZNPL	A2924	6
21	SWITCH ROTARY LIMIT 25:1 GF4C 4-POLE	A5029	1
22	MACHSCR HEXHD 10-24NC X .750 ZNPL STL	A3871	2
23	WASHER FLT SAE #10 X .500 X .049 ZNPL	A1059	2
24	NUT HEX NYLK 10-24NC ZNPL GR2	A3315	2
25	SPROCKET MACH 25 20TH M12ID X .187 PIN	A9665	2
26	PIN SLOTTED SPRING .187 X 1.250 STL	A2849	2
27	ROLLCHAIN CONLINK 25 X .25P SPRGLCP	A9604	1
28	ROLLCHAIN 25 X .25P 76 PITCHES	A9666	1
29	GUARD RLS CHAIN 8PW	B5019	1
30	CAPSCR HEXHD .312-18NC X .500 ZNPL GR5	A3507	4
31	FLANGLE DRUM PW SERIES .375	SEE TABLE	
32	SPACER DRUM PW SERIES G []	SEE TABLE	
33	SPACER DRUM END 8PW	SEE TABLE	
34	SPACER DRUM END 8PW	SEE TABLE	
35	SHAFT DRUM END CAP 8PW	A9928	1
36	CAPSCR SOKFLTHD .625-11NC X 1.500 ZNPL	A9934	1
37	CAPSCR HEXHD .438-14NC X [] GR5	SEE TABLE	4
38	NUT HEX NYLK .438-14NC PLAIN GR2	A9828	1
39	LABEL THERN STAGE EQUIPMENT	A10126	1
40	LABEL NAMEPLATE POWER WINCHES	A9556	1
41	LABEL WARNING READ FOR POWER WINCHES	SA5756	1
42	LABEL WARNING KEEP HANDS AWAY FROM DRUM	A2659	1
43	LABEL WARNING DO NOT MANUALLY RELEASE BRAKE	A2481	2
44	LABEL WARNING DISCONNECT ELECTRIC POWER	A2256	1

BILL OF MATERIALS												
model	lines	rope dia.	ITEM 13 drum shaft	ITEM 15 shaft key	QTY, ITEM 31 drum flange	QTY, ITEM 32 spacer	QTY, ITEM 33 spacer	ITEM 34 spacer	ITEM 37 capscr			
PW12-4Px19	4	3/16"	B5027	A6983	5	B5207	4	B5208	1	A10388	A9924	A9788
PW12-5Px19	5	3/16"	B5027	A6983	6	B5207	5	B5208	-	-	A9924	A9789
PW12-6Px19	6	3/16"	B5027	A6983	7	B5207	6	B5208	-	-	-	A9795
PW12-7Px19	7	3/16"	B5032	A10425	8	B5207	7	B5208	3	A10388	-	A9796
PW12-8Px19	8	3/16"	B5032	A10425	9	B5207	8	B5208	2	A10388	-	A9797
PW12-9Px19	9	3/16"	B5032	A10425	10	B5207	9	B5208	1	A10388	-	A10172
PW12-10Px19	10	3/16"	B5032	A10425	11	B5207	10	B5208	-	-	-	A10184
PW12-2Px25	2	1/4"	B5027	A6983	3	B5207	2	B5209	3	A10389	A10390	A9786
PW12-3Px25	3	1/4"	B5027	A6983	4	B5207	3	B5209	2	A10389	A10390	A9787
PW12-4Px25	4	1/4"	B5027	A6983	5	B5207	4	B5209	1	A10389	A10390	A9789
PW12-5Px25	5	1/4"	B5027	A6983	6	B5207	5	B5209	-	-	A10390	A9794
PW12-6Px25	6	1/4"	B5032	A10425	7	B5207	6	B5209	3	A10389	-	A9795
PW12-7Px25	7	1/4"	B5032	A10425	8	B5207	7	B5209	2	A10389	-	A9797
PW12-8Px25	8	1/4"	B5032	A10425	9	B5207	8	B5209	1	A10389	-	A10172
PW12-9Px25	9	1/4"	B5032	A10425	10	B5207	9	B5209	-	-	-	A10184

PW12

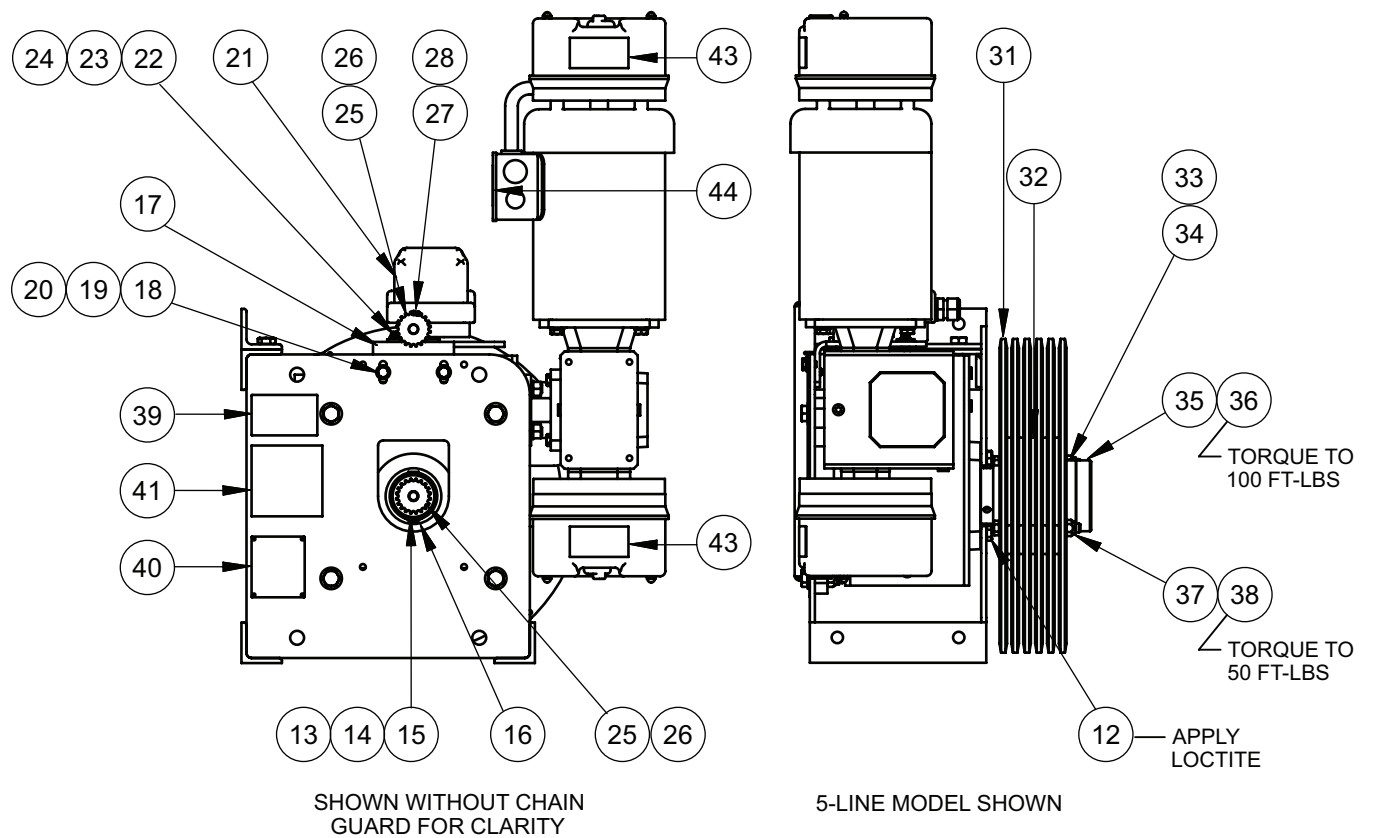
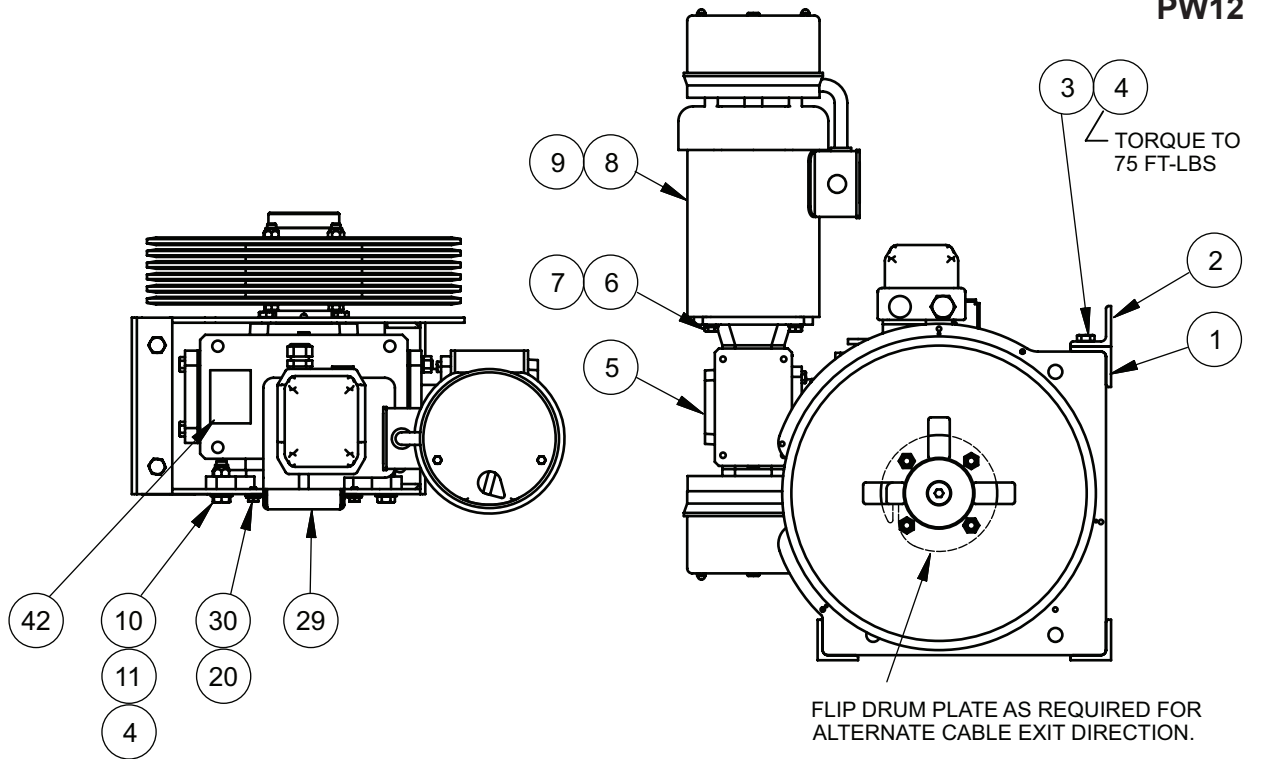

Model PW21 Pilewind Hoist			
item	description	part number	qty.
1	WELDMENT FRAME 8PW2	C4516	1
2	ANGLE FRAME 8PW2	B5016	1
3	CAPSCR HEXHD .625-11NC X 1.500 ZNPL GR5	A3476	2
4	NUT HEX NYLK .625-11NC ZNPL GR2	A3072	6
5 (C)	REDUCER 250:1 WITH 200V BRAKE	B5163	1
5 (D)	REDUCER 250:1 WITH 230/460V BRAKE	B5033	1
6	CAPSCR HEXHD .500-13NC X 1.250 ZNPL GR5	A2928	4
7	WASHER HELSPRLK .500 X .873 X .125 ZNPL	A2930	4
8 (C)	MOTOR BRK 3.0HP 1740 RPM 208/3/60	B5185	1
8 (D)	MOTOR BRK 3.0HP 1740 RPM 230/460/3/60	B5219	1
9	KEY .250 X .250 X 1.750 4140 HT BER	A2674	1
10	CAPSCR HEXHD .625-11NC X 2.000 ZNPL GR5	A3475	4
11	WASHER FLT SAE .625 X 1.312 X .095 ZNPL	A4858	4
12	CAPSCR HEXHD .500-13NC X 0.750 ZNPL GR5	A3524	4
13	SHAFT DRUM PW 2.687	SEE TABLE	1
14	KEY .625 X .625 X 2.750 4140 HT BER	A4893	2
15	KEY .625 X .625 X [] 4140 HT BER	SEE TABLE	1
16	RING RET EXT 2.688 SPRSTL	A9933	1
17	BRACKET RLS MOUNTING 8PWS2	B5018	1
18	CAPSCR HEXHD .312-18NC X 0.750 ZNPL GR5	A3032	2
19	WASHER HELSPRLK .312 X .586 X .078 ZNPL	A2925	2
20	WASHER FLT SAE .312 X .688 X .065 ZNPL	A2924	6
21	SWITCH ROTARY LIMIT 25:1 GF4C 4-POLE	B5029	1
22	MACHSCR HEXHD 10-24NC X .750 ZNPL STL	A3871	2
23	WASHER FLT SAE #10 X .500 X .049 ZNPL	A1059	2
24	NUT HEX NYLK 10-24NC ZNPL GR2	A3315	2
25	SPROCKET MACH 25 20TH M12ID X .187 PIN	A9665	2
26	PIN SLOTTED SPRING .187 X 1.250 STL	A2849	2
27	ROLLCHAIN CONLINK 25 X .25P SPRGCLP	A9604	1
28	ROLLCHAIN 25 X .25P PITCHES	A9666	1
29	GUARD RLS CHAIN 8PW	B5019	1
30	CAPSCR HEXHD .312-18NC X .500 ZNPL GR5	A3507	4
31	FLANGE DRUM PW SERIES .375	SEE TABLE	
32	SPACER DRUM 8PW SERIES G []	SEE TABLE	
33	SPACER DRUM END 8PW	SEE TABLE	
34	SPACER DRUM END 8PW	SEE TABLE	
35	SHAFT DRUM END CAP 8PW	A9928	1
36	CAPSCR SOKFLTHD .625-11NC X 1.500 ZNPL	A9934	1
37	CAPSCR HEXHD .438-14NC X [] GR5	SEE TABLE	4
38	NUT HEX NYLK .438-14NC PLAIN GR2	A9828	4
39	LABEL NAMEPLATE THERN LOGO	A6889	1
40	LABEL NAMEPLATE POWER WINCHES	A9556	1
41	LABEL WARNING READ FOR POWER WINCHES	SA5756	1
42	LABEL WARNING KEEP HANDS AWAY FROM DRUM	A2659	1
43	LABEL WARNING DO NOT MANUALLY RELEASE BRAKE	A2481	2
44	LABEL WARNING DISCONNECT ELECTRIC POWER	A2256	1

BILL OF MATERIALS

model	lines	rope dia.	ITEM 13 drum shaft	ITEM 15 shaft key	QTY, ITEM 31 drum flange	QTY, ITEM 32 spacer	QTY, ITEM 33 spacer	ITEM 34 spacer	ITEM 37 capscr			
PW21-6Px19	6	3/16"	B5026	A4894	7	B5207	6	B5208	1	A10388	A10390	A9795
PW21-7Px19	7	3/16"	B5026	A4894	8	B5207	7	B5208	-	-	A10390	A9796
PW21-8Px19	8	3/16"	B5231	A10425	9	B5207	8	B5208	2	A10388	-	A9797
PW21-9Px19	9	3/16"	B5231	A10425	10	B5207	9	B5208	1	A10388	-	A10172
PW21-10Px19	10	3/16"	B5231	A10425	11	B5207	10	B5208	-	-	-	A10184
PW21-4Px25	4	1/4"	B5026	A4894	5	B5207	4	B5209	2	A10389	A9924	A9789
PW21-5Px25	5	1/4"	B5026	A4894	6	B5207	5	B5209	1	A10389	A9924	A9794
PW21-6Px25	6	1/4"	B5026	A4894	7	B5207	5	B5209	-	-	A9924	A9795
PW21-7Px25	7	1/4"	B5231	A10425	8	B5207	7	B5209	2	A10389	-	A9797
PW21-8Px25	8	1/4"	B5231	A10425	9	B5207	8	B5209	1	A10389	-	A10172
PW21-9Px25	9	1/4"	B5231	A10425	10	B5207	9	B5209	-	-	-	A10184

PW21

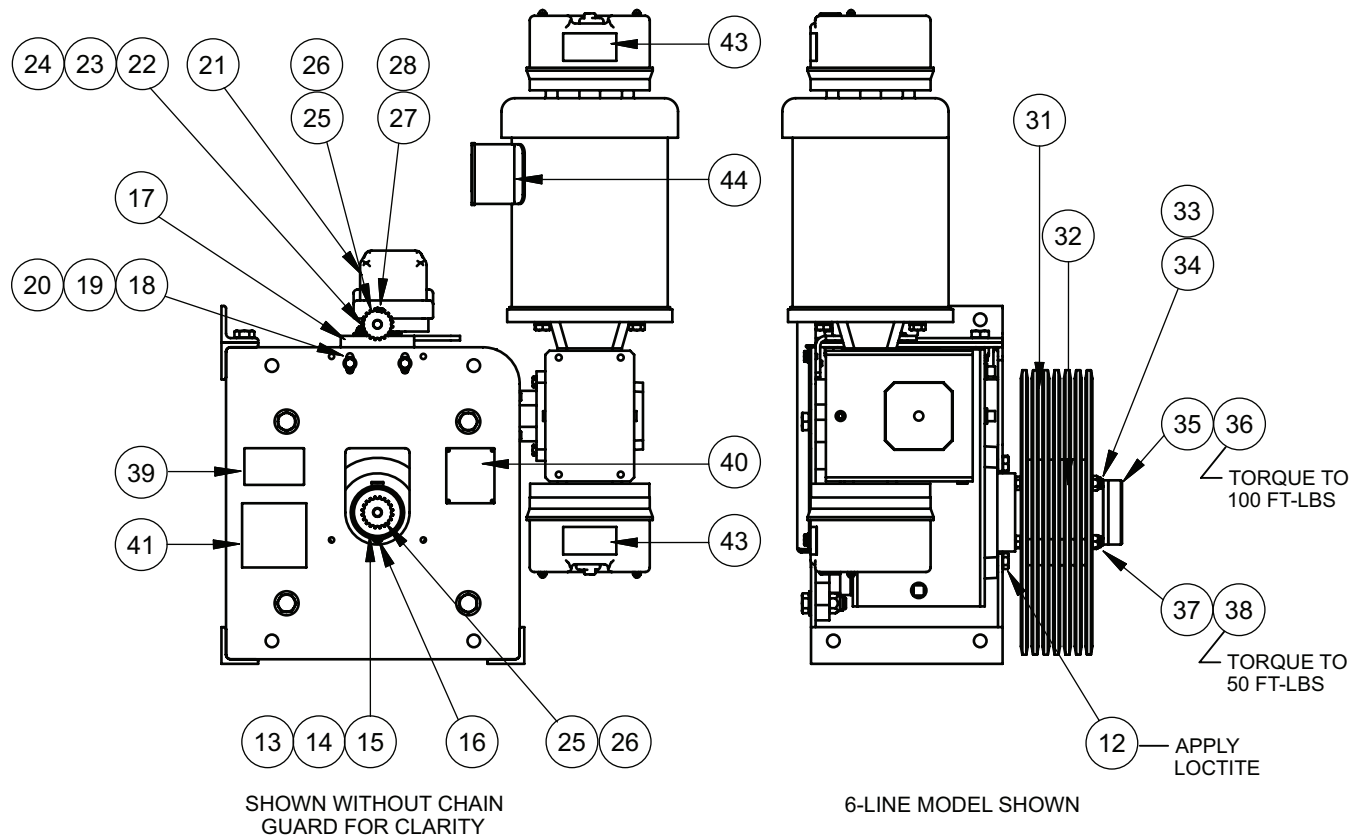
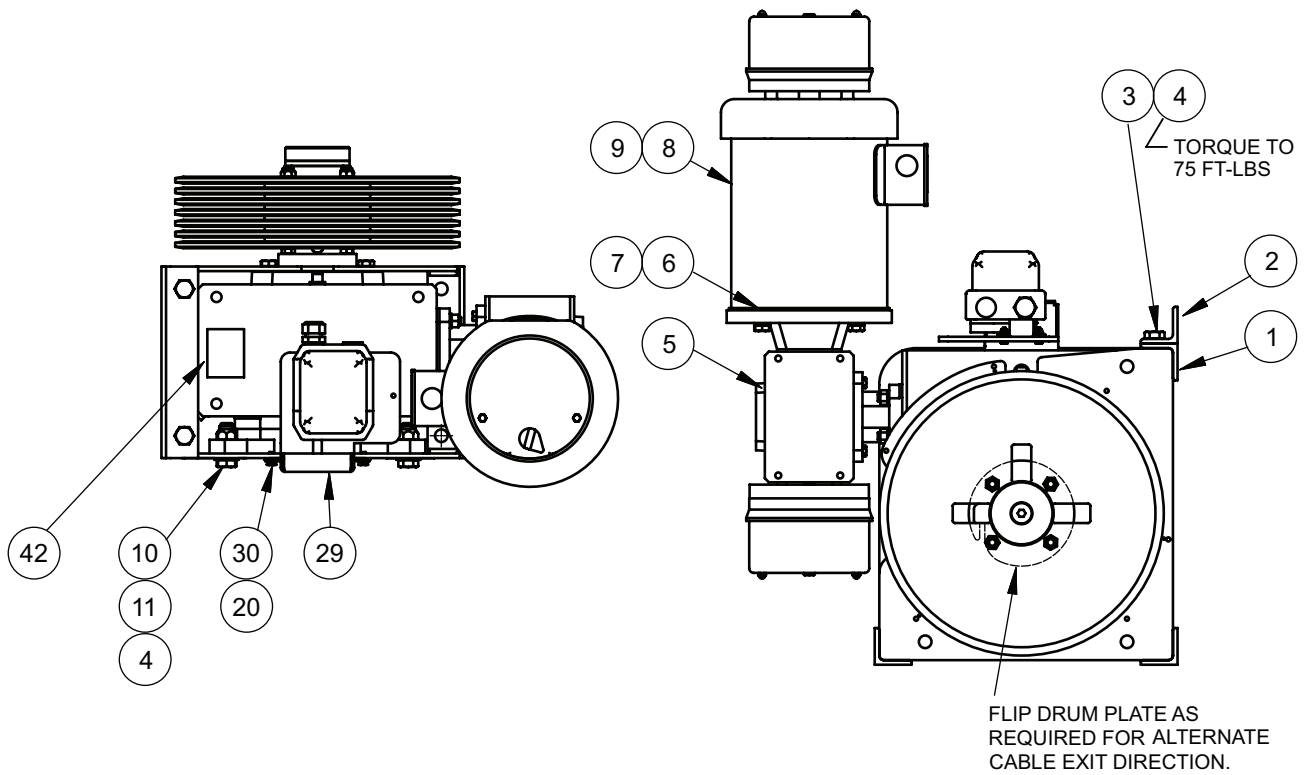



Thern Stage Equipment
5712 Industrial Park Road
Winona, MN 55987

PHN 507-454-2996
FAX 507-454-5282

EMAIL: info@thernstage.com
www.thernstage.com