

8 | 7 | 6 | 5 | 4 | 3 | 2 | 1

H - HEAD
 B - BLOCK
 # - SHEAVE DIAMETER
 -
 D - UNDERHUNG MOUNTING
 # - NUMBER OF GROOVES
 N - SHEAVE MATERIAL (N=NYLATRON, S=STEEL)
 # - ROPE SIZE (LIFT LINE)
 S - SINGLE
 P - PURCHASE

MODEL	CAPACITY	DIM A	DIM B	WEIGHT
HB12-D6N25SP	3000 LBS	2.21 [56mm]	4.98 [127mm]	56.41 LBS
HB12-D8N25SP	3000 LBS	3.08 [78mm]	5.86 [149mm]	60.38 LBS
HB12-D10N25SP	3000 LBS	3.96 [101mm]	6.73 [171mm]	64.32 LBS
HB12-D6S25SP	3000 LBS	2.21 [56mm]	4.98 [127mm]	73.68 LBS
HB12-D8S25SP	3000 LBS	3.08 [78mm]	5.86 [149mm]	80.90 LBS
HB12-D10S25SP	3000 LBS	3.96 [101mm]	6.73 [171mm]	88.03 LBS

NOTES:

- MAXIMUM RATED CAPACITY :
 - MAY EXCEED CAPACITY OF THE ROPE.
 - USE ROPE MANUFACTURER'S RATING AND SAFETY FACTOR TO DETERMINE LOAD LIMIT.
 - WHEN PROPERLY INSTALLED, MAINTAINED AND OPERATED.
 - IS BASED ON CABLES WRAPPED 90 DEGREES AROUND THE SHEAVE.
- MOUNTING HARDWARE MUST BE DISTRIBUTED EVENLY.
 - MINIMUM OF 4 ATTACHMENT POINTS.
- CONTACT FACTORY FOR NON-STANDARD REQUIREMENTS.

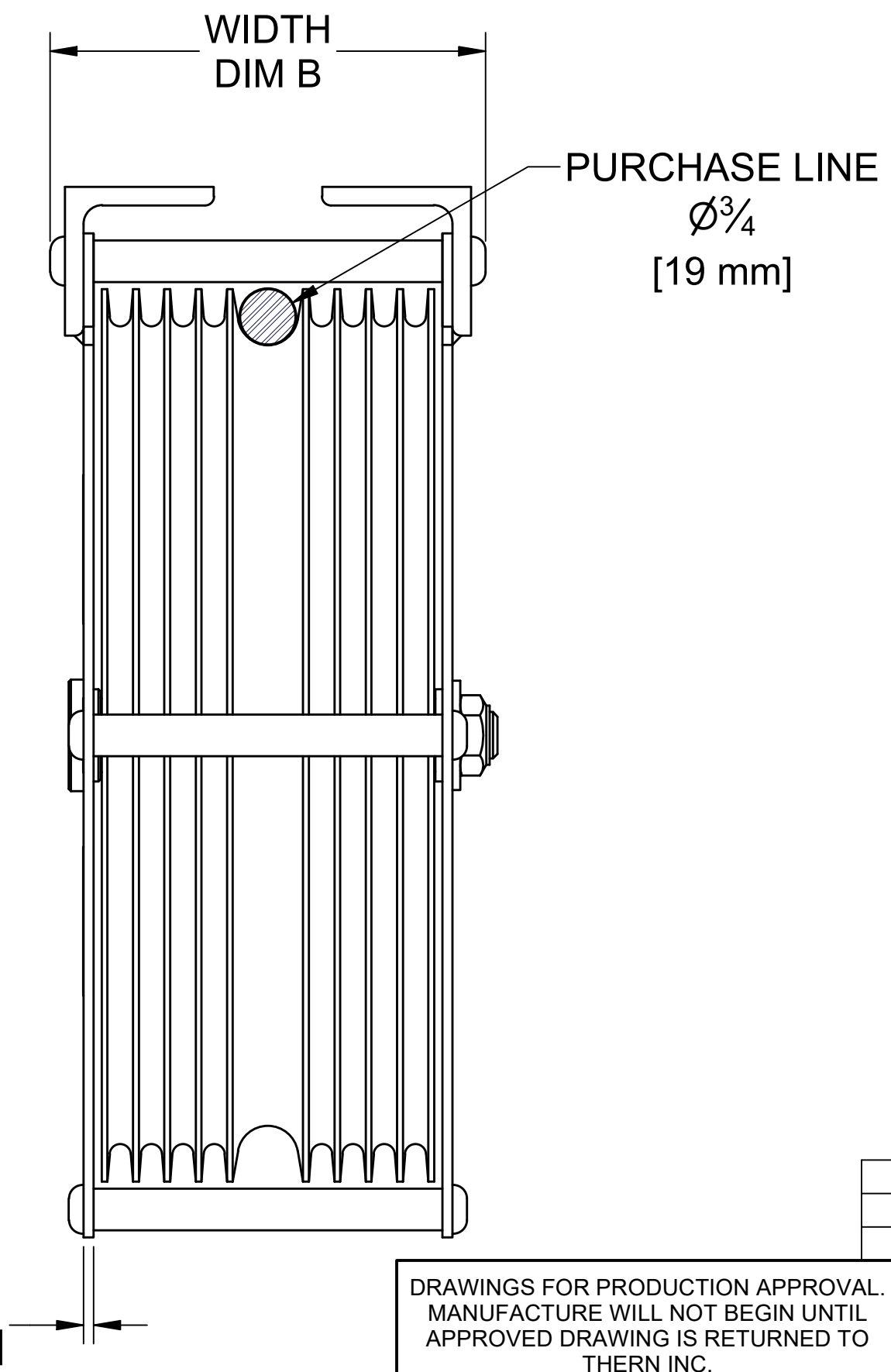
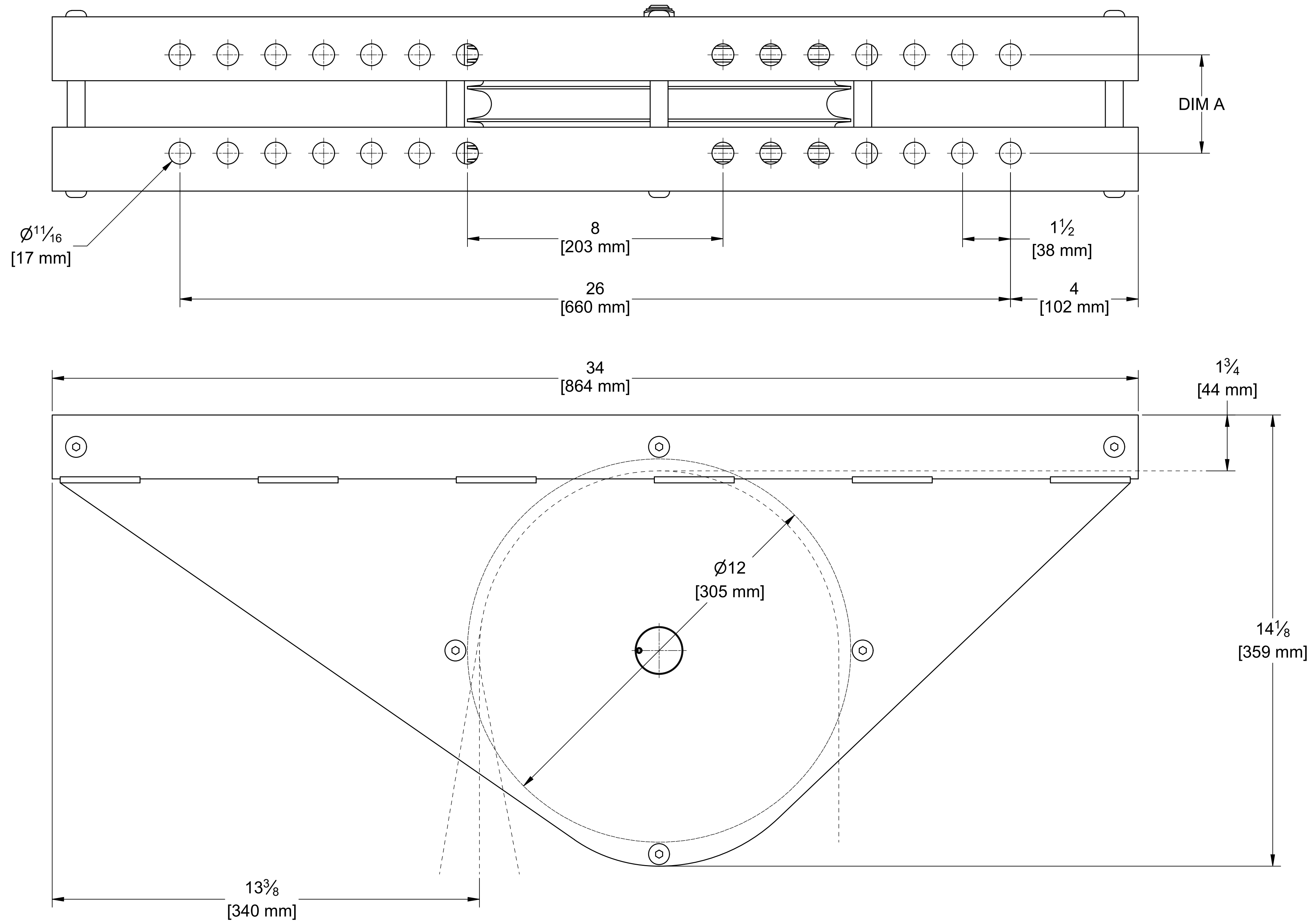

ZONE	REV	AUTHOR	DATE	DESCRIPTION
		JCA	11/02/2021	SEE ECN #15020

DRAWINGS FOR PRODUCTION APPROVAL. MANUFACTURE WILL NOT BEGIN UNTIL APPROVED DRAWING IS RETURNED TO THERN INC.

COMPANY NAME _____
 PRINT NAME _____
 SIGNATURE _____ DATE _____

THIS PRINT AND THE INFORMATION HEREIN IS THE PROPERTY OF THERN INC AND MUST NOT BE REPRODUCED EITHER IN FULL OR IN PART WITHOUT WRITTEN APPROVAL BY THERN INC.		INCH UNITS UNLESS OTHERWISE SPECIFIED. TOLERANCES UNLESS SPECIFIED: FRAC. ± 1" ANGLE ± 9'	
MODEL	12" HEAD BLOCK UNDR SP	SCALE	1/2
DATE	10/26/2015	DESCRIPTION	DIMENSIONAL DRAWING
DRAWN BY	JCA	SHEET NO.	D
WEIGHT		REVISION	A
		SHT 1 OF 2	



5712 INDUSTRIAL PARK ROAD
 WINONA, MN 55987
 PHONE 1-507-454-2996
 WWW.THERN.COM

8 | 7 | 6 | 5 | 4 | 3 | 2 | 1