

NOTES:

1. USE STANDARD STOP SLEEVES OR SWAGED BALL ENDS TO RETAIN FIRST WIRE ROPE LAYER.
2. KEEP FOUR (4) WRAPS OF WIRE ROPE WOUND ON DRUM AT ALL TIMES TO SERVE AS ANCHOR WRAPS. CABLE SHOULD BE MARKED TO IDENTIFY THESE ANCHOR WRAPS.
3. UNLESS SPECIFIED, UNITS ARE SHIPPED FROM THE FACTORY FILLED WITH LUBRICANT BASED ON THE MOUNTING ORIENTATION SHOWN. INSTALL THE SUPPLIED VENT PLUG (SHIPPED LOOSE) AND VERIFY OIL LEVELS AS SPECIFIED BY THE REDUCER MANUFACTURER PRIOR TO INSTALLATION.

DO NOT MIX LUBRICANT TYPES.
4. SPECIAL MOTOR AND BRAKE CONFIGURATIONS MAY REQUIRE A SPECIFIC INPUT SHAFT ORIENTATION. CONTACT FACTORY.
5. CONTACT FACTORY FOR NON-STANDARD REQUIREMENTS.

STANDARD SPECIFICATIONS

MODEL	PW12 SERIES	PW21 SERIES
WORKING LOAD LIMIT	1200 LBS	2100 LBS
MOTOR - 3 ϕ , 208 - 230/460 VAC	1.5 HP	3.0 HP
FULL LOAD AMPS (208 VAC)	5.7	10.2
FULL LOAD AMPS (230/460 VAC)	5.2 / 2.7	9.2 / 4.7
TOTAL GEAR RATIO	250 : 1	250 : 1
NUMBER OF LINES	4 TO 10	6 TO 10
WIRE ROPE SIZE	ϕ 3/16"	ϕ 3/16"
MAXIMUM TRAVEL	51 FT	51 FT
D : d RATIO (MIN, 1st WORKING LAYER)	30	30
AVERAGE LINE SPEED	20 FPM	20 FPM
LIMIT SWITCH	4 POSITION	4 POSITION
REDUNDANT FAIL SAFE BRAKES	STANDARD	STANDARD
DRUM GUARD	OPTIONAL	OPTIONAL
DESIGN FACTOR	8 : 1	8 : 1

* SPECIFY VOLTAGE

* SPECIFY QUANTITY

DIM A (INCHES)	12.00	14.00
DIM B	13.00	15.00
DIM C	15.50	17.50
DIM D	6.00	8.00
DIM E	ϕ 9/16	ϕ 11/16
DIM F	2.50	2.70
DIM G - UP THRU 6 LINES	14.88	18.50
DIM G - UP THRU 10 LINES	17.38	20.00
DIM H	32.00	35.62
DIM K	21.44	24.88

WEIGHT (LBS)

LINES	PW12 SERIES	PW21 SERIES
4	393	-
5	412	-
6	431	608
7	455	627
8	474	649
9	493	668
10	512	687

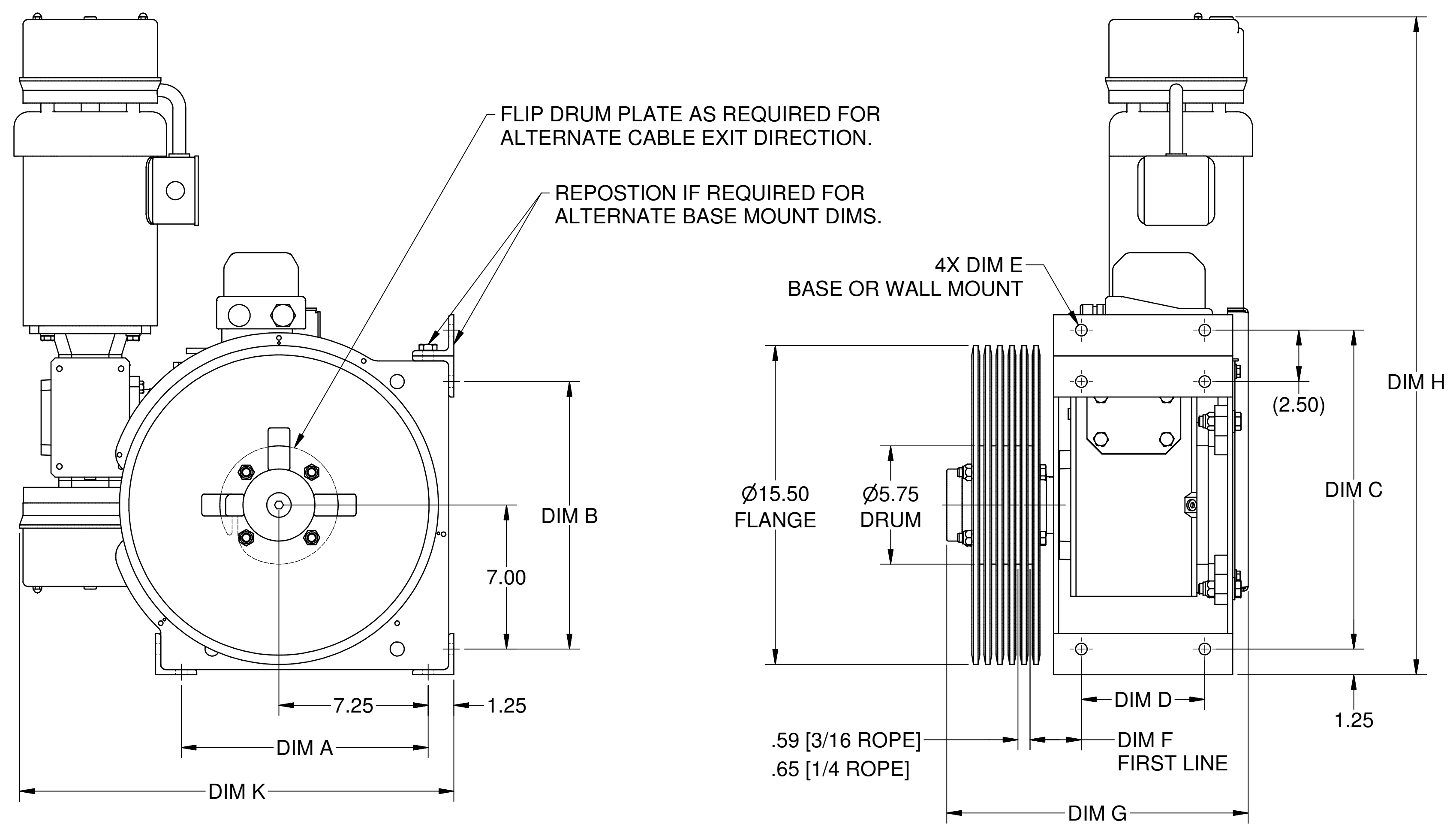

DRUM DIAMETER vs. LOAD CAPACITY
(4 ANCHOR WRAPS, EVENLY DISTRIBUTED LOAD)

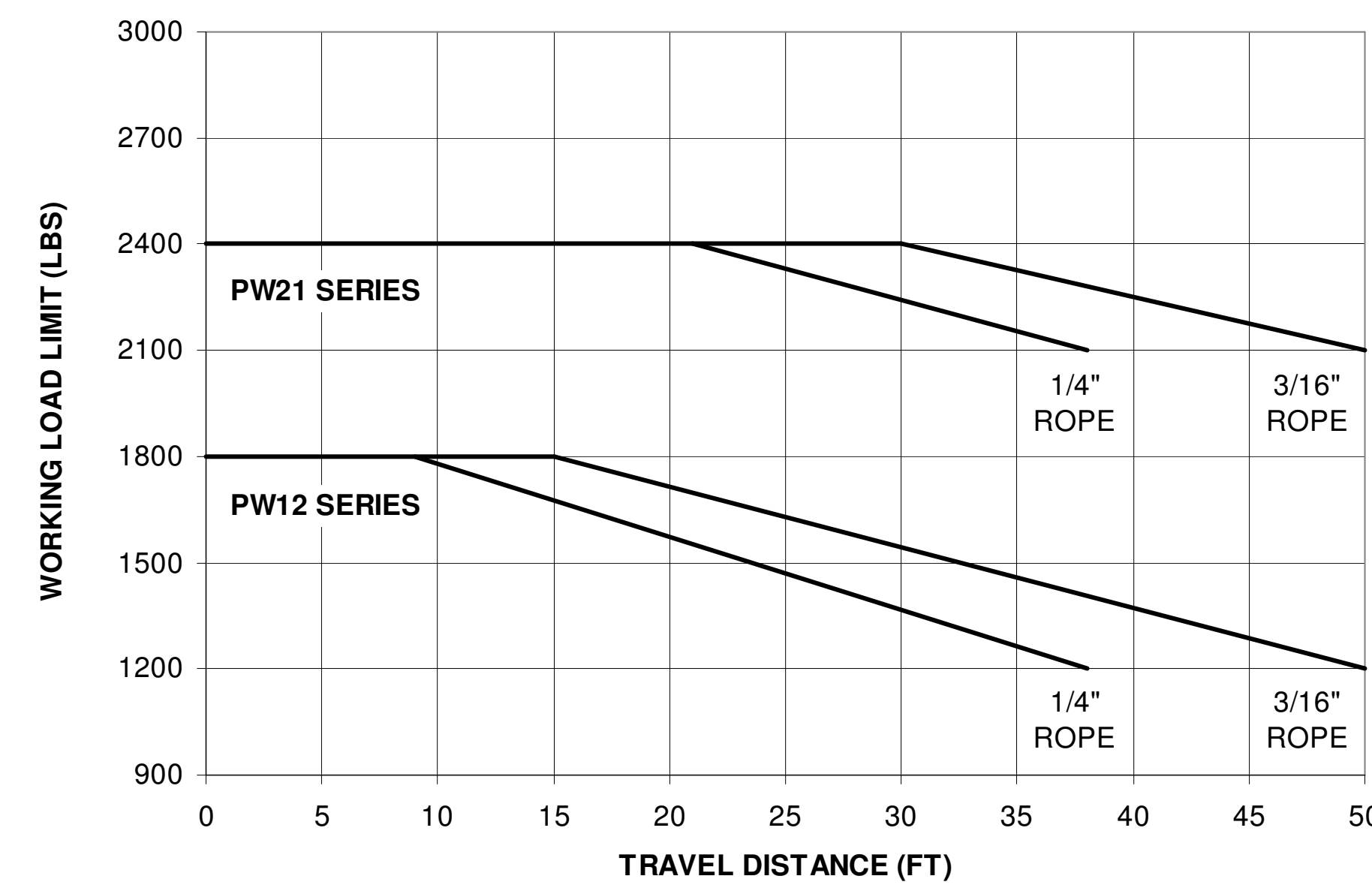

THIS PRINT IS THE PROPERTY OF TERN AND MUST NOT BE REPRODUCED EITHER IN FULL OR IN PART WITHOUT WRITTEN APPROVAL BY TERN.

TSE TERN STAGE EQUIPMENT

5712 INDUSTRIAL PARK ROAD
WINONA, MN 55987
PHONE 1-800-553-2204
FAX 1-507-454-5282

TOLERANCES UNLESS SPECIFIED
FRAC. \pm 1" ANGLE \pm 5"
DO NOT SCALE DRAWING

DESCRIPTION POWER PILE WIND		DRAWING NUMBER D3480	
MODEL PW SERIES		SCALE NTS	
DRAWN BY JCA	DATE 10/1/2009	WEIGHT N/A	REVISION SHEET 1 OF 1