

NOTES:

1. USE STANDARD STOP SLEEVES OR SWAGED BALL ENDS TO RETAIN FIRST WIRE ROPE LAYER.
2. KEEP FOUR (4) WRAPS OF WIRE ROPE WOUND ON DRUM AT ALL TIMES TO SERVE AS ANCHOR WRAPS. CABLE SHOULD BE MARKED TO IDENTIFY THESE ANCHOR WRAPS.
3. UNLESS SPECIFIED, UNITS ARE SHIPPED FROM THE FACTORY FILLED WITH LUBRICANT BASED ON THE MOUNTING ORIENTATION SHOWN. INSTALL THE SUPPLIED VENT PLUG (SHIPPED LOOSE) AND VERIFY OIL LEVELS AS SPECIFIED BY THE REDUCER MANUFACTURER PRIOR TO INSTALLATION.
DO NOT MIX LUBRICANT TYPES.
4. CONTACT FACTORY FOR NON-STANDARD REQUIREMENTS.

STANDARD SPECIFICATIONS

MODEL	PW12 SERIES	PW18 SERIES
WORKING LOAD LIMIT	1200 LBS	1800 LBS
DRILL-DRIVE LOAD LIMIT *	700 LBS	900 LBS
GEAR RATIO	25 : 1	50 : 1
NUMBER OF LINES	4 TO 10	5 TO 10
WIRE ROPE SIZE	Ø3/16"	Ø3/16"
MAXIMUM TRAVEL	51 FT	51 FT
D : d RATIO (MIN, 1st WORKING LAYER)	30	30
FAIL SAFE BRAKE	STANDARD	STANDARD
DRUM GUARD	OPTIONAL	OPTIONAL
DESIGN FACTOR	8 : 1	8 : 1
* SPECIFY QUANTITY		
DIM A (INCHES)	12.00	14.00
DIM B	13.00	15.00
DIM C	15.50	17.50
DIM D	6.00	8.00
DIM E	Ø9/16	Ø11/16
DIM F	2.50	2.70
DIM G - UP THRU 6 LINES	14.63	17.75
DIM G - UP THRU 10 LINES	17.13	19.25
DIM H	17.50	19.50
DIM K	20.63	22.00

* DRILL-DRIVE OPERATION BASED ON DRILL RATED FOR 10 AMPS AT 250 RPM. REDUCE LOAD BY 20% WHEN USING A DRILL RATED FOR 10 AMPS AT 350 RPM.

WEIGHT (LBS)

LINES	PW12 SERIES	PW18 SERIES
4	324	-
5	343	462
6	362	481
7	386	500
8	405	522
9	424	541
10	443	560

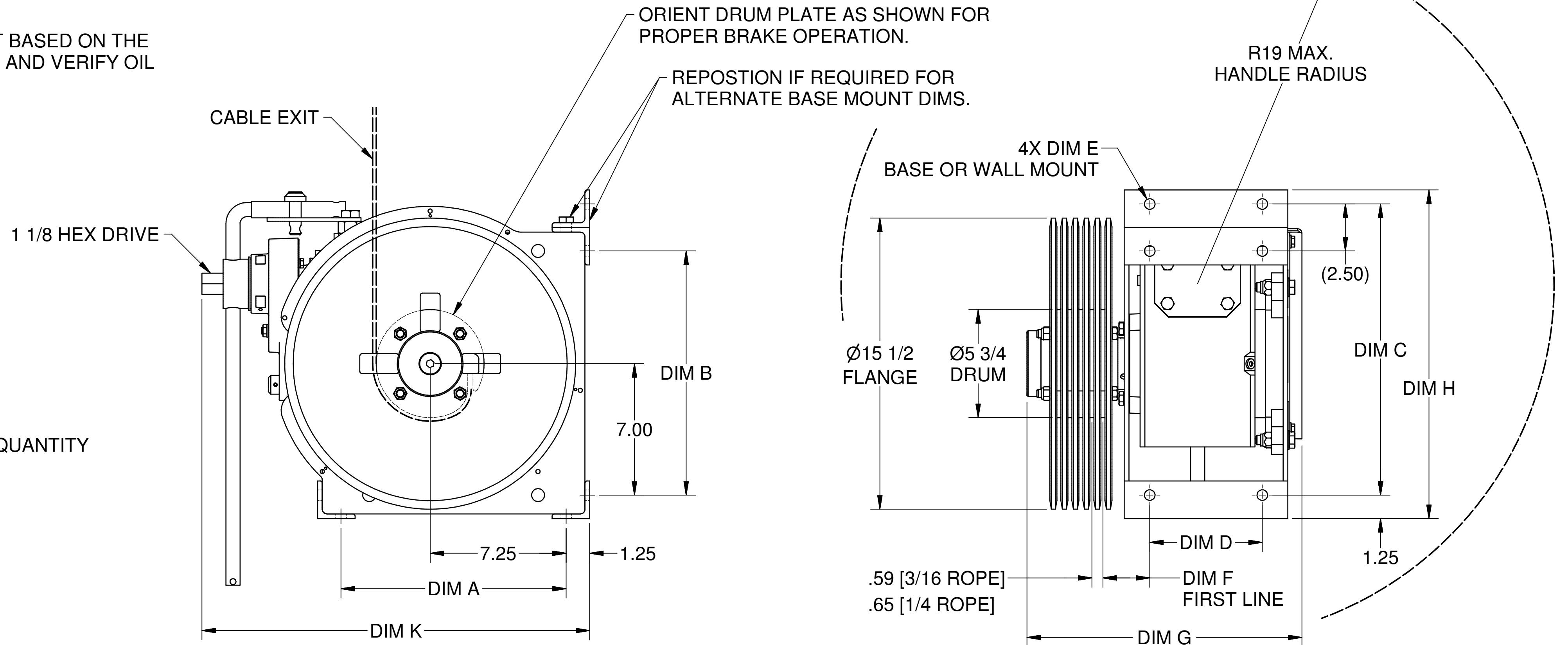

DRUM DIAMETER vs. TYPICAL HANDLE EFFORT
(4 ANCHOR WRAPS, FULL LOAD CAPACITY)

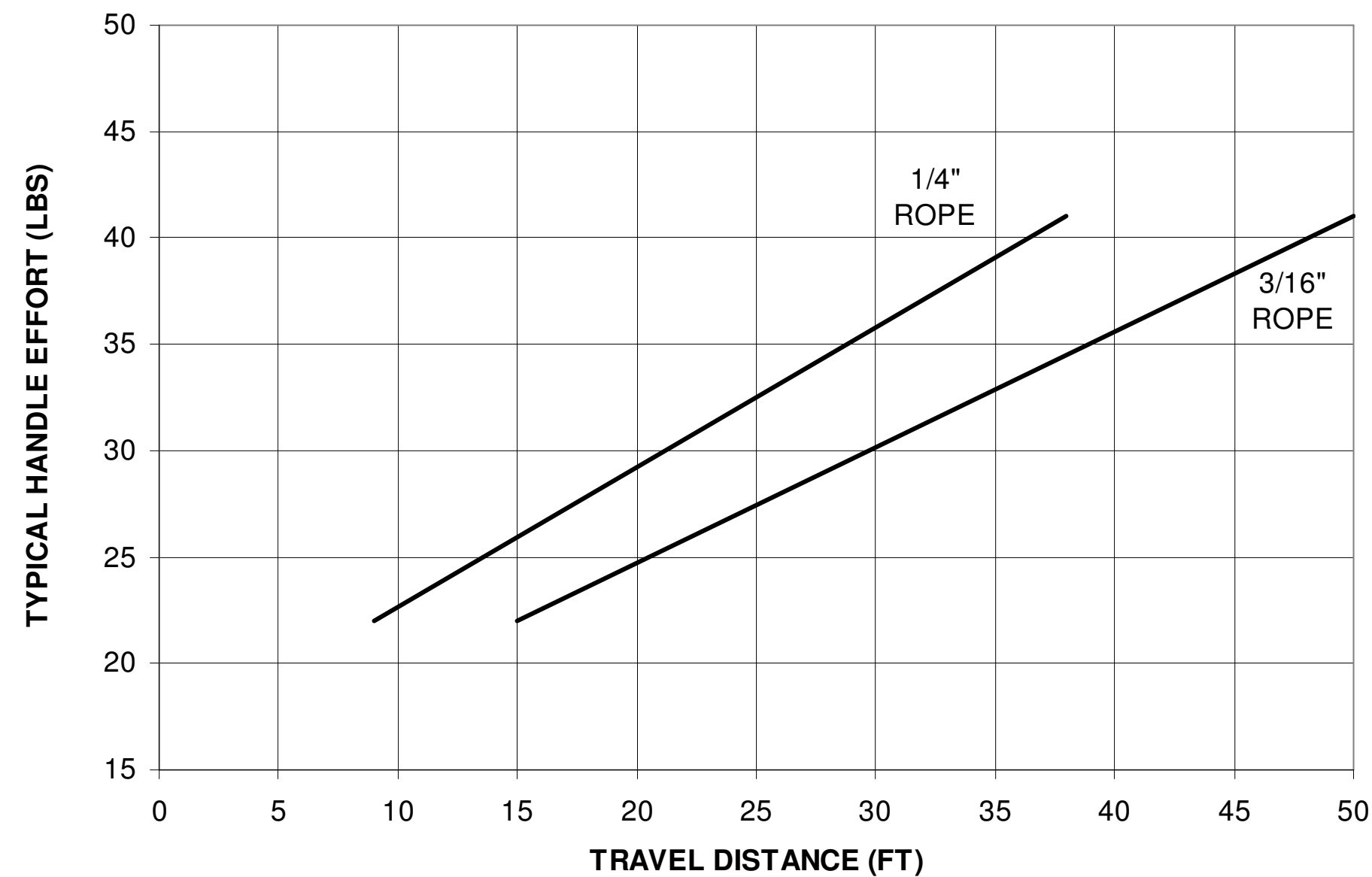

THIS PRINT IS THE PROPERTY OF TERN AND MUST NOT BE REPRODUCED EITHER IN FULL OR IN PART WITHOUT WRITTEN APPROVAL BY TERN.		TSE TERN STAGE EQUIPMENT		5712 INDUSTRIAL PARK ROAD WINONA, MN 55987 PHONE 1-800-553-2204 FAX 1-507-454-5282	
DESCRIPTION MANUAL PILE WIND				TOLERANCES UNLESS SPECIFIED FRAC. ± 1" ANGLE ± 5" DO NOT SCALE DRAWING	
MODEL PW SERIES				DRAWING NUMBER D3482	
DRAWN BY JCA	DATE 10/2/2009	WEIGHT N/A	SCALE NTS	REVISION	SHEET 1 OF 1