

DESIGN ALLOWS FOR SIDE-BY-SIDE NESTED MOUNTING ON 8 INCH CENTERS

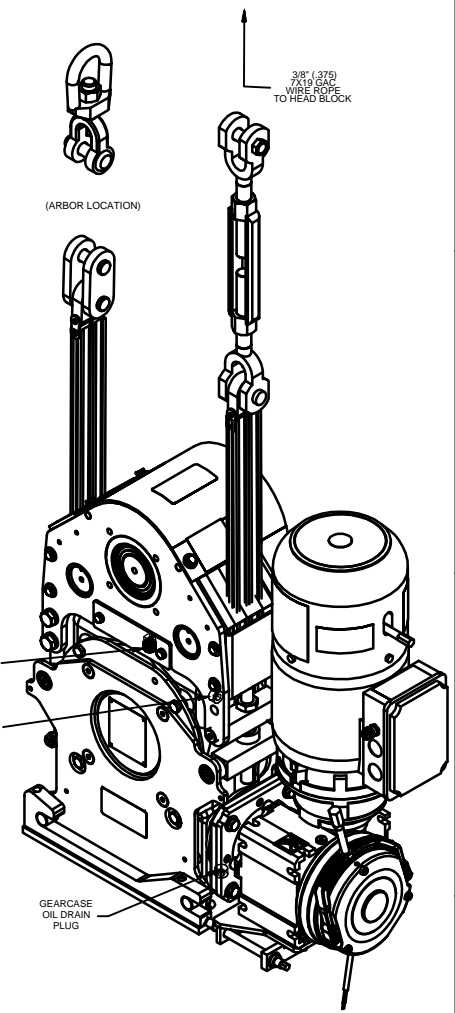
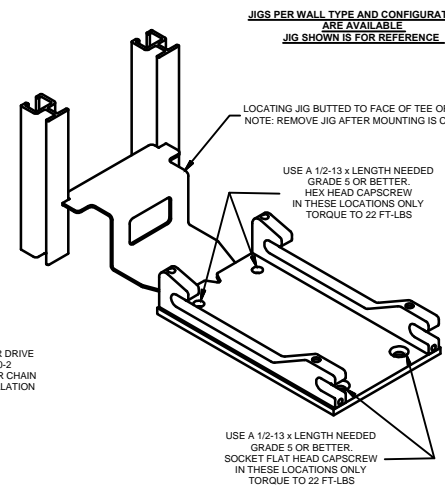
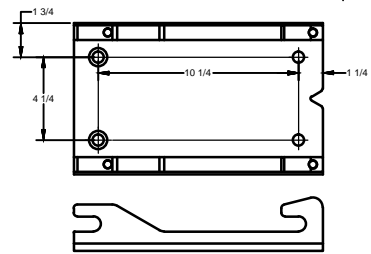
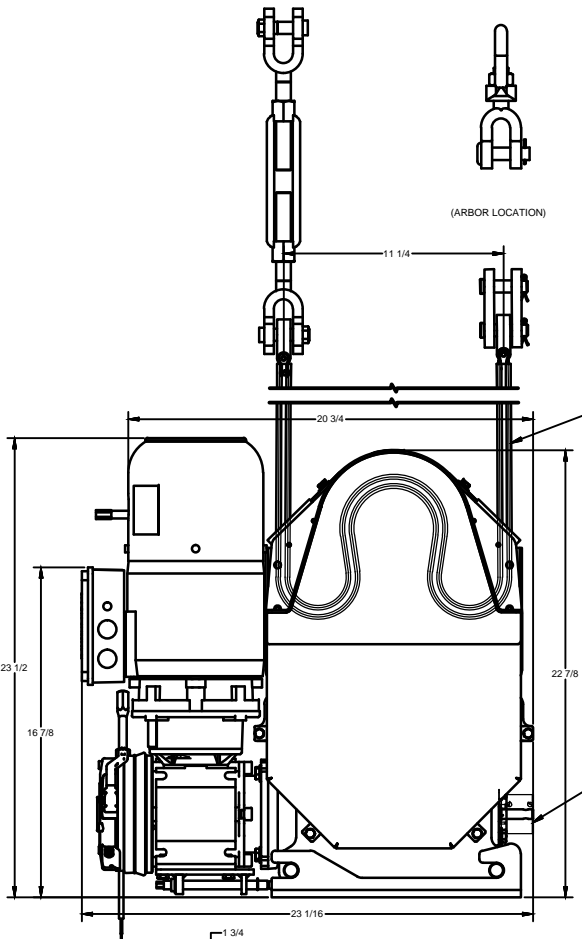

HOIST SPECIFICATION	
DESCRIPTION	SPECIFICATION
WORKING LOAD LIMIT	1500 LBS
LINE SPEED	24 FT/MIN
MOTOR HP	2.0
MOTOR VOLTAGE	208
FULL LOAD AMPS	6.2@208V
TOTAL RATIO	155:1
HOIST MOUNTING ANCHOR TENSILE LOAD	834 LBS PER BOLT

TOLERANCES UNLESS OTHERWISE SPECIFIED:  
 X .002  
 Y .005  
 Z .010  
 ANG. ± .010  
 FINISH: RA .125  
 REMOVE ALL BURRS  
 DO NOT SCALE DRAWING

DESCRIPTION: DIMENSIONAL DRAWING

THIS PRINT IS THE PROPERTY OF THERN, INC. AND MUST NOT BE REPRODUCED EITHER IN FULL OR IN PART WITHOUT WRITTEN APPROVAL BY THERN, INC.

DATE: 8/27/2017

SCALE: 3/16" = 1"

WEIGHT: 276 LBS

3MC

THERN, INC.  
 3175 INDUSTRIAL PARK ROAD  
 518 800 007  
 WINONA, MN 55957  
 PHONE: 507-564-2955  
 FAX: 507-564-2952

D4718