

SIDE VIEW

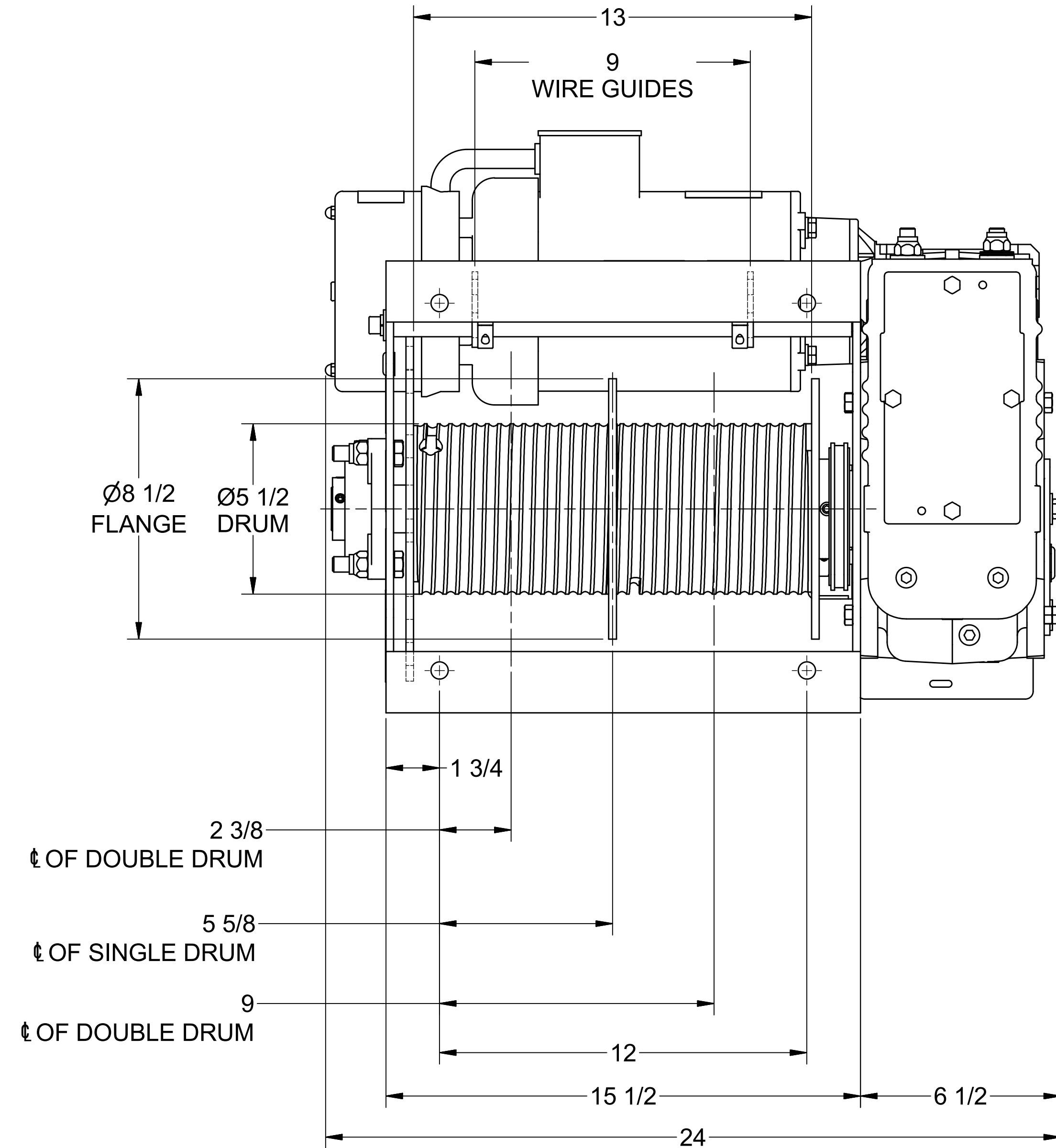

REAR VIEW

CW25 POWER SERIES CHARACTERISTICS	
WORKING LOAD LIMIT	2500 LBS
TOTAL GEAR RATIO	232.50 : 1
FULL LOAD AMPS (208 VAC)	5.4
FULL LOAD AMPS (230/460 VAC)	5 / 2.5
MAXIMUM TRAVEL **	40 FT
D : d RATIO	18.5
LINE SPEED	11 FPM
LIMIT SWITCH	4 POSITION
FAIL SAFE BRAKE	STANDARD
DESIGN FACTOR	8 : 1
WEIGHT	223 LBS

PART NUMBER SELECTION			
MODEL	DRUM TYPE	ROPE SIZE	MOTOR PROPERTIES
CW25-2PC	DOUBLE	Ø5/16"	1.5 HP 208, 3Ø
CW25-2PD	DOUBLE	Ø5/16"	1.5 HP 230/460, 3Ø
CW25-1PC	SINGLE	Ø3/8"	1.5 HP 208, 3Ø
CW25-1PD	SINGLE	Ø3/8"	1.5 HP 230/460, 3Ø

*SPECIFY VOLTAGE

NOTES:

1. USE STANDARD STOP SLEEVES OR SWAGED BALL ENDS TO ANCHOR WIRE ROPE.
2. KEEP FOUR (4) WRAPS OF WIRE ROPE WOUND ON DRUM AT ALL TIMES TO SERVE AS ANCHOR WRAPS.
3. INSTALL SUPPLIED BREATHER PLUG AFTER INSTALLATION. SEE OWNERS MANUAL FOR DETAILS.
4. CONTACT FACTORY FOR NON-STANDARD REQUIREMENTS.

** GREATER TRAVEL POSSIBLE AT REDUCED LOAD RATINGS, CONTACT FACTORY.

NOT FOR CONSTRUCTION

THIS PRINT IS THE PROPERTY OF THERN AND MUST NOT BE REPRODUCED EITHER IN FULL OR IN PART WITHOUT WRITTEN APPROVAL BY THERN.		TSE THERN STAGE EQUIPMENT		5712 INDUSTRIAL PARK ROAD WINONA, MN 55987 PHONE 1-800-553-2204 FAX 1-507-454-5282	
DESCRIPTION POWER CLEW WINCH				TOLERANCES UNLESS SPECIFIED FRAC. ± 1" ANGLE ± 5' DO NOT SCALE DRAWING	
MODEL CW25 SEREIS				DRAWING NUMBER D3456	
DRAWN BY JP	DATE 3/22/2010	WEIGHT	SCALE NTS	REVISION	SHEET 1 OF 1