

TSE **THERN** **STAGE** **EQUIPMENT**

Read this Owner's Manual thoroughly before operating the equipment. Keep it with the equipment at all times. Replacements are available from Thern Stage Equipment, PO Box 347, Winona, MN 55987, 800-553-2204. www.thernstage.com



ORIGINAL TEXT

Owner's Manual **For** **Thern Brickhouse FL Series Arbor Based** **Counterweight Rigging System**

Two-Year Limited Warranty

Please record the following:

Date Installed:

Model Numbers:

Head Block(s):

Loft Block(s):

Arbor:

Floor Block:

Rope Lock:

Guide Shoes:

This information is required when calling the factory for service.

Thern, Inc. warrants its products against defects in material or workmanship for two years from the date of purchase by the original using buyer, or if this date cannot be established, the date the product was sold by Thern, Inc. to the dealer. To make a claim under this warranty, contact the factory for an RGA number. The product must be returned, prepaid, directly to Thern, Inc., 5712 Industrial Park Road, Winona, Minnesota 55987. The following information must accompany the product: the RGA number, the date of purchase, the description of the claimed defect, and a complete explanation of the circumstances involved. If the product is found to be defective, it will be repaired or replaced free of charge, and Thern, Inc. will reimburse the shipping cost within the contiguous USA.

This warranty does not cover any damage due to accident, misuse, abuse, or negligence. Any alteration, repair or modification of the product outside the Thern, Inc. factory shall void this warranty. This warranty does not cover any costs for removal of our product, downtime, or any other incidental or consequential costs or damages resulting from the claimed defects. This warranty does not cover brake discs, wire rope or other wear components, as their life is subject to use conditions which vary between applications.

FACTORY AUTHORIZED REPAIR OR REPLACEMENT AS PROVIDED UNDER THIS WARRANTY IS THE EXCLUSIVE REMEDY TO THE CONSUMER. THERN, INC. SHALL NOT BE LIABLE FOR ANY INCIDENTAL OR CONSEQUENTIAL DAMAGES FOR BREACH OF ANY EXPRESS OR IMPLIED WARRANTY ON THIS PRODUCT. EXCEPT TO THE EXTENT PROHIBITED BY APPLICABLE LAW, ANY IMPLIED WARRANTY OF MERCHANTABILITY OR FITNESS FOR A PARTICULAR PURPOSE ON THIS PRODUCT IS LIMITED IN DURATION TO THE DURATION OF THIS WARRANTY.

Some states do not allow the exclusion or limitation of incidental or consequential damages, or allow limitations on how long an implied warranty lasts, so the above limitation or exclusion may not apply to you. This warranty gives you specific legal rights, and you may also have other rights which vary from state to state.

Note: Thern, Inc. reserves the right to change the design or discontinue the production of any product without prior notice.

About This Manual

The Occupational Safety and Health Act of 1970 states that it is the employer's responsibility to provide a workplace free of hazard. To this end, all equipment should be installed, operated, and maintained in compliance with applicable trade, industrial, federal, state, and local regulations. It is the equipment owner's responsibility to obtain copies of these regulations and to determine the suitability of the equipment to its intended use.

This Owner's Manual, and warning labels attached to the equipment, are to serve as guidelines for hazard-free installation, operation, and maintenance. They should not be understood to prepare you for every possible situation.

Information contained in this Owner's Manual is applicable only to Thern FL Series Counterweight Arbors. Do not use this manual as a source of information for any other equipment.

The following symbols are used for emphasis throughout this manual:

▲WARNING

Failure to follow 'WARNING!' instructions may result in equipment damage, property damage, and/or serious personal injury.

▲CAUTION

Failure to follow 'CAUTION!' instructions may result in equipment damage, property damage, and/or minor personal injury.

Important!

Failure to follow 'Important!' instructions may result in poor performance of the equipment.

Suggestions for Safe Operation

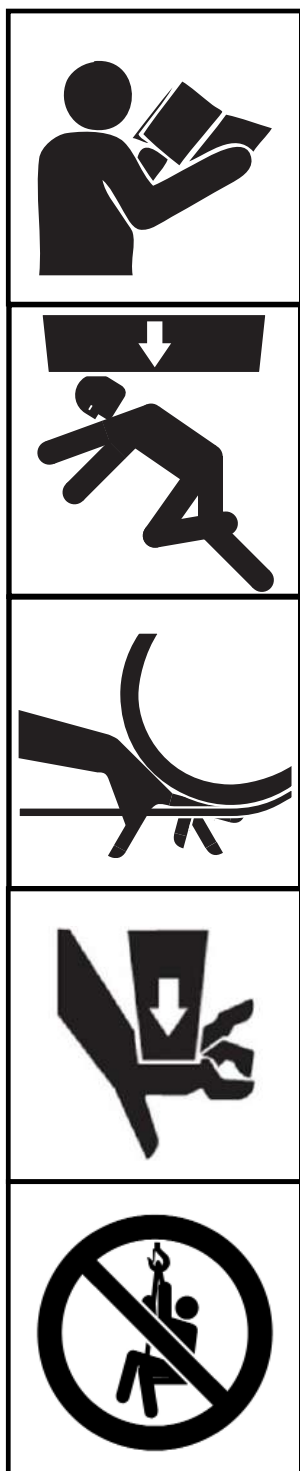

⚠️WARNING

DO the following:

Read and comply with the guidelines set forth in this Owner's Manual. Keep this manual, and all labels attached to the equipment, readable and with the equipment at all times. Contact Thern, Inc. for replacements.

Keep sets in balance during operation. This means the weight of the load equals the arbor and counterweights. Operators must completely understand methods of maintaining system balance.

Keep hands away from moving parts of the equipment and other pinch points such as cable, sheaves, guide wall, arbor gate, counterweights, and rope lock.

Keep the arbor gate securely closed at all times, except while loading or unloading counterweights.

Use caution while installing equipment. Empty arbors are heavy. Rigging attachment points are located at the top and bottom of the arbor.

DO NOT do the following:

This product is designed for lifting and moving material only. Do not use this product for any other purpose.

Do not operate stage rigging without proper supervision, training and authorization. Know the limitations of your system.

Do not exceed the load rating of the equipment or any other component in the system. To do so could result in failure of the equipment.

Do not use damaged or malfunctioning equipment. To do so could result in failure of the equipment.

Do not modify the equipment in any way. To do so could cause equipment failure.

Do not operate arbor unless the arbor gate is securely in the closed position.

Do not wrap the wire rope around the batten. This damages the wire rope and could cause the batten to fall. Use approved rigging connectors to secure the wire rope to the batten.

Do not operate with guards or covers removed or improperly installed.

Do not load or unload the arbor when anyone is below the arbor or load batten.

Do not divert your attention from the operation. Stay alert to the possibility of accidents, and try to prevent them from happening.

Do not jerk or swing the load. Avoid shock loads by starting and stopping the load smoothly. Shock loads overload the equipment and may cause damage.

Do not leave an out of balance load unattended and keep people clear of the batten and the lock rail while the load is out of balance.

Do not attempt to stop a run away set. If an out of balance set begins to fall, move away and clear the area until the set has stopped moving.

Do not use rope locks to hold out-of-balance loads greater than 50 pounds.

1.1 Theory of Operation

Important!

- Rope locks should be adjusted by authorized personnel to hold an out of balance load not exceeding 50 pounds.
- Rope locks should be adjusted to grip but not crush the rope.
- Adjustments should be checked regularly as temperature, humidity, load and wear can change rope diameter.
- For significantly out of balance sets, they should be tied off in a manner that will securely hold the load, until the set can be brought into balance once again.
- Exact balance is only achieved midway during load travel due to the weight of the wire rope passing over the head and loft blocks.
- If the set cannot be balanced exactly, it is suggested to set the arbor heavy to prevent accidental lowering of the batten.

A counterweight set is a mechanical system designed to move stage and lighting equipment vertically by means of arbors and loft blocks. Counterweights located in an arbor are used to balance a load over the stage which reduces the amount of force required to raise and lower the load.

When the arbor is at its lowest point and the batten is at its maximum height just below the loft blocks, the set is said to be 'FULL OUT'. When the arbor is at its maximum height and the batten is at the lowest position, the set is said to be 'FULL IN'.

The load is in balance when the force of the counterweights is equal to the force of the load. If the load is greater than the counterweight directly below the head block, it is referred to as being 'batten heavy'. If the counterweight is greater than the load below the loft blocks, it is referred to as being 'arbor heavy'. When the system is in balance, the force required to move the set should only be the amount needed to overcome friction and inertia.

- 1.1.1 THE LOAD consists of any batten, scenery or lighting equipment and wire rope located below the loft blocks.
- 1.1.2 THE ARBOR holds the counterweights used to counterbalance the load. The line used to operate the set is routed to the top and bottom of the arbor.
- 1.1.3 COUNTERWEIGHTS are made from steel or other metal. Arbor gates have a spring return feature to ensure they are in the correct position. These gates provide added security to prevent the weights from coming out of the arbor.
- 1.1.4 HEAD BLOCKS collect and change direction of lift lines. They are located between the arbor and the loft blocks. Head blocks carry the full load of the set. They also support and direct the hand line.
- 1.1.5 LOFT BLOCKS are used to support lift lines and direct movement of load travel. They are located between the head block and the load.
- 1.1.6 FLOOR BLOCKS maintain hand line tension and change hand line direction. They are located below the arbor.
- 1.1.7 HAND LINE is used to control movement of the arbor and the load. If the hand line is pulled down, the arbor rises and the batten lowers.
- 1.1.8 ROPE LOCKS are used to hold balanced loads in position.
- 1.1.9 BATTENS are pipes, trusses or other rigging supported by the lifting cables. Stage and lighting equipment is clamped or tied to the batten.
- 1.1.10 SINGLE PURCHASE ARBOR SYSTEM, or 1:1 system, means that the line sets are rigged in such a manner that the batten travels the same distance the arbor travels. This also means the arbor must carry the same load as the batten. For every pound of batten weight, there should be one (1) pound of arbor weight. See Figure 1.
- 1.1.11 DOUBLE PURCHASE ARBOR SYSTEM, or 2:1 system, means that the line sets are rigged in such a manner that the batten travels twice the distance the arbor travels. This also means the arbor must carry twice the load of the batten. For every pound of batten weight, there should be two (2) pounds of arbor weight. See Figure 2.

1.2 Preparing for Operation

Important!

- Keep people clear of areas under the arbor, loading gallery and load batten during operation.
- Identify empty trim weight for each batten to prevent the weights from being accidentally removed. These permanent counterweights should be marked for easy identification or secured in place.
- The batten counterbalances the empty arbor. If the batten is too light, the empty arbor could move uncontrollably.

The key to successful operation of a counterweight system is to maintain balance and stability. The system must either be 'in balance' or the system should be set slightly arbor heavy to prevent accidental lowering of the batten.

- 1.2.1 **CONSIDER THE OPERATION.** Do not begin until you are sure you can perform the entire operation without hazard.
- 1.2.2 **INSPECT ALL PARTS** of the system.
 - a **OBSERVE THE SYSTEM** and look for signs of problems. See Section 2.1.2.
 - b **OPERATORS** must be in good health, alert, thoroughly trained in operating the equipment and properly clothed. Wear heavy-duty gloves, safety shoes, and remove any loose jewelry.
 - c **THE LOAD** must be clear of other objects and free to move. Make sure the load will not tip, spin, roll away or in any other way move uncontrollably.
- 1.2.3 **KNOW YOUR LOAD** and make sure you do not exceed the load rating of the equipment or any other component in the system.
- 1.2.4 **IT IS UP TO THE OPERATOR** to determine the best method of operation. When making this determination, keep the following factors in mind:
 - a the design of your system,
 - b personnel training and competency,
 - c equipment resources,
 - d the degree of out of balance that might be encountered.
- 1.2.5 **THE SET SHOULD BE ASSESSED** for hazards, their severity and possible protective action.

Figure 1 – Single Purchase

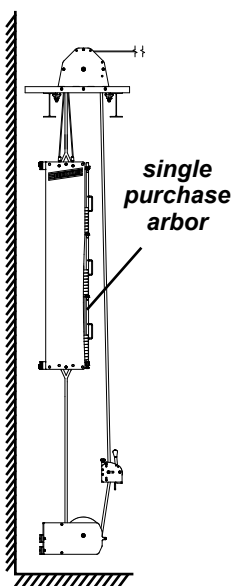
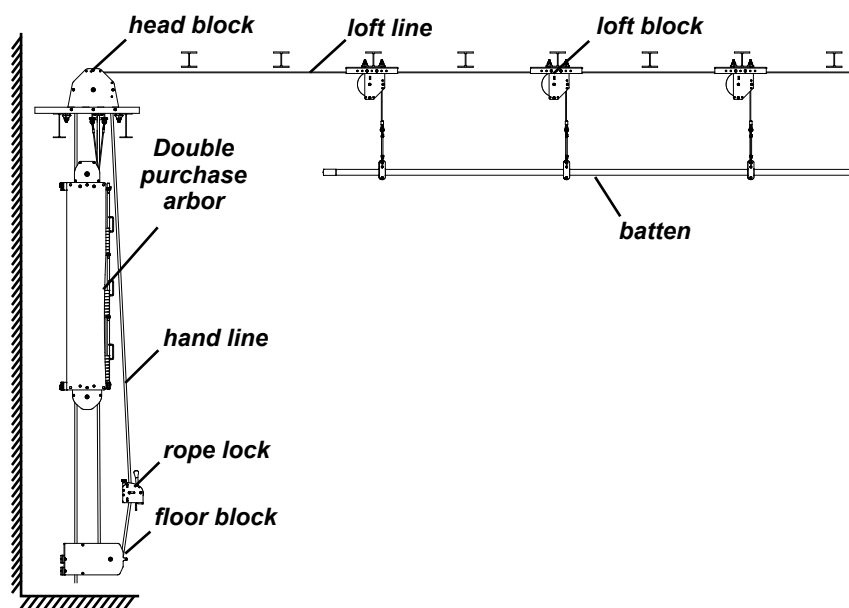

Figure 2 – Double Purchase



1.3 Operating the Counterweight Set

Important!

- Obey a stop signal from anyone.
- Appoint a supervisor if more than one person is involved in the operation. This will reduce confusion and increase safety.
- If there are several lift lines, or if travel distance is long, the set may not be balanced at the end of travel due to the transferred weight of cables. Get help if operation becomes difficult.
- Due to friction inherent with set operation, it may be necessary to pull a balanced set both up and down. If excessive pull is required, or operation becomes unusual, stop operation immediately, engage the rope lock and determine the problem.

⚠WARNING

Always check for people or obstructions before operating. People must not be near or under moving arbors or battens.

Do not operate arbor unless the arbor gate is securely in the closed position.

Out of balance loads may cause equipment damage and serious injury.

You are responsible for identifying and evaluating any hazards and determining the correct and most secure operation method to be used, especially when operating an out-of-balance system.

- 1.3.1 IDENTIFY THE ARBOR visually.
- 1.3.2 LOOK FOR OBSTRUCTIONS that may disrupt operation before beginning operation.
- 1.3.3 OBSERVE THE FRONT AND BACK HAND LINES to help determine condition of the set balance. When the front line is taut and the rear is loose, the line set is arbor heavy; if the rear is taut and the front is loose, the line set is batten heavy. If the set is out of balance, correct it before continuing. If you are unable to correct the balance, consult a competent individual and perform a hazard assessment before continuing.
- 1.3.4 WHEN PROPERLY BALANCED the counterweight set will be close to neutral balance at the halfway point of travel. When at full in or full out travel position, the counterweight set out of balance should not exceed 50 pounds.
- 1.3.5 TO OPERATE THE SET release the rope lock handle slowly until set balance can be determined.
- 1.3.6 WHEN THE BATTEN reaches its desired position, engage the rope lock. If a position must be found repeatedly, the hand line can be marked by stabbing string through or wrapping with spike tape. Avoid using adhesive tape as it will leave a sticky residue.
- 1.3.7 OUT OF BALANCE SYSTEMS must be operated with extreme caution. Systems without a loading gallery or systems that have poor access to the arbors may require operators to work with out of balance loads. Care should be taken while loading and unloading to maintain balance between the arbor and the batten. Ensure that precautions are taken to prevent any imbalance from causing the line set to move. If the arbor begins to move, STOP the balance procedure and inspect the device used to temporarily hold the imbalance. Some loads experience an out of balance situation as they are raised or lowered. Loads such as tall curtains shift weight to the batten as they are raised and weight is removed from the floor, causing the counterweight set to be batten-heavy. Conversely, as the load is lowered this will cause shifting of the load from the batten to the floor, causing the set to be arbor-heavy. Careful consideration and preparation must be taken when working with out of balance systems or situations.
- 1.3.8 HAND LINE MAY STRETCH OR SHRINK due to changes in load or humidity. The set may become harder to operate. The system has an adjustable floor block to compensate for slack or relieve extra tension. **We recommend periodic tightening of the hand line at the bottom termination or by adjusting the position of the tension floor block.**

Figure 3 – Arbor Gate

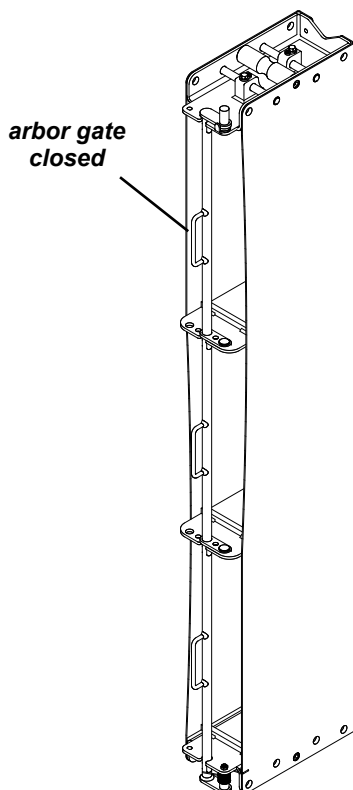

1.4 Handling and Loading Counterweights

Important!

- Battens and arbors should be labeled with the set number and load capacity. Do not exceed rated capacity.
- Arbor gate should always be securely closed while not actively loading or unloading counterweights.
- While loading or unloading, keep a safety person near the area to prevent unauthorized use and to keep people a safe distance from the work area.
- Always maintain complete control over the weights. Falling weights can cause severe injury or death.
- Keep fingers, etc. out from under the counterweights while loading. Be aware of pinch points between the handholds of counterweights while unloading. See Figure 4.
- Exact balance is only achieved midway during the load travel due to the weight of the wire rope passing over the head and loft blocks.
- Store unused weight securely.
- An established protocol of communication between workers on the load floor and at the lock rail should be implemented to reduce confusion and confirm actions and movements.

⚠ WARNING

Falling counterweights can damage equipment and cause serious injury.

Do not load or unload the arbor when anyone is below the arbor or load batten.

Securely close the arbor gate when loading is complete.

Alternate methods of loading and unloading may be required depending on the facility's personnel and available equipment.

Use only counterweights designed and approved for use in the FL Series arbor.

- 1.4.1 COUNTERWEIGHTS are typically made of steel or ductile cast iron. A slot is provided at one end which allows the arbor gate to close and function properly. Individual counterweight mass should not normally exceed 30 pounds for handling by an average worker.
- 1.4.2 ATTACHING LOADS and loading arbors.
- Bring the empty batten to the 'full in' position just above the floor. Engage the rope lock. The arbor should be securely positioned against the upper stop rail and in balance.
 - Remove all counterweights from the arbor, except for 'pipe weight' used to balance the weight of the empty batten. This ensures a stable condition where the batten (at its lowest level) is the same weight or heavier than the arbor.
 - Securely attach loads (scenery, track, lighting, etc.) to the batten. Use appropriate rigging hardware that is strong enough to hold the load and in good condition. Do not overload the batten.
 - Open the arbor gate by grasping a handle and lifting the gate. Swing the gate to the open position and lower the gate. Pick up a counterweight and using both hands, slide the counterweight past the hand line into any arbor shelf. Loading can occur at any available shelf location and does not need to begin at the bottom shelf. Use the heel of your hand to push on the front face of the counterweight to verify that it is fully inserted into the arbor. A counterweight that is incorrectly positioned will not allow the arbor gate to completely close. If a loading gallery is present, add as many bricks to the arbor as necessary to balance the batten load. If no loading gallery is present, see Section 1.3.7 for special precautions pertaining to out of balance systems.

Figure 4 – Counterweight Brick Pinch Points

Fingers can become pinched between bricks during loading and unloading when handholds are misaligned.

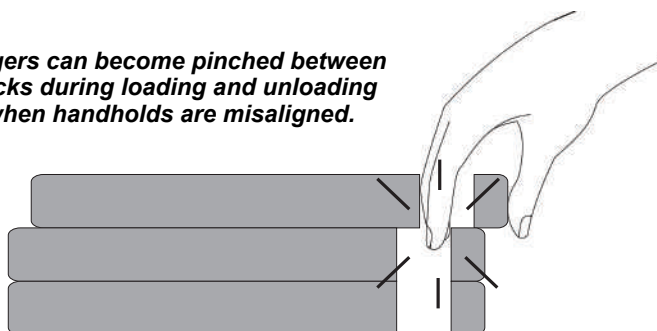

- e Close the arbor gate by grasping a handle, lifting, and then swinging the gate back to the closed position. Lower the gate fully to secure the gate. Note that the gate is under some spring tension. Ease the arbor gate to the closed position. A tug on the arbor gate without lifting verifies that the gate is secure.
 - f The set should always be in balance or otherwise under control before releasing the rope lock. Tension in the hand line may indicate an out-of-balance set. See Section 1.3.
 - g Adjust arbor weight until balance has been achieved using steps "d" and "e". Remember that rope locks should not be used to hold more than 50 pounds. Adjusting the rope lock to hold additional out-of-balance loads may result in dangerous uncontrolled movements and damage equipment.
- 1.4.3 IF THE SET cannot be balanced exactly, it is usually better to make the set slightly arbor heavy to prevent the load batten from accidentally falling.
- 1.4.4 REMOVING LOADS and unloading arbors.
- a Removing or 'striking' loads is generally performed by reversing the order of the loading procedure.
 - b Bring the loaded batten to the 'full in' or 'low trim' position just above the floor, Engage the rope lock. The arbor should be securely positioned against the upper stop rail.
 - c Open the arbor gate by grasping a handle and lifting the gate. Swing the gate to the open position and lower the gate. Remove a counterweight by grasping the counterweight by the handhold, pulling straight back past the hand line, and supporting the rear of the counterweight with your other hand. Do not remove counterweights below the yellow indicator plate, as these consist of 'pipe weight', which balances the permanent loads such as the batten, trim chains, curtain tracks, etc.
 - d If a loading gallery is present and the batten is at low trim, unload the batten ONLY after the counterweights have been unloaded. If no loading gallery is present, see Section 1.3.7 for special precautions pertaining to out of balance systems.
 - e Close the arbor gate by grasping a handle, lifting, and then swinging the gate back to the closed position. Lower the gate fully to secure the gate. Note that the gate is under some spring tension. Ease the arbor gate to the closed position. A tug on the arbor gate without lifting verifies that gate is secure.
 - f Verify the system is balanced within 50 pounds before releasing the rope lock.

2.1 General Inspection

Important!

- Start an inspection program as soon as you put the system into use.
- Appoint a qualified person to be responsible for regularly inspecting the equipment.
- Keep written records of inspection. This allows comparison with comments from previous inspections so you can see changes in condition or performance.
- Make sure to properly dispose of old ropes to prevent re-use.
- Always wear protective clothing when handling wire rope.

⚠WARNING

Do not use damaged or malfunctioning equipment. Place an 'OUT OF ORDER' sign on the line set. Do not use the line set until sign is removed by a qualified person who has completely corrected the problem.

It is the responsibility of the owner to keep up with regular inspection and maintenance of the equipment as well as continuous training of the operators.

- 2.1.1 A VARIETY OF FACTORS, including time, temperature, humidity, and frequency and severity of operation, affect system components creating the need for regular inspection. To help maintain functional equipment and reduce maintenance issues do the following:
- a Keep your equipment and surrounding areas clean. Clean up any dirt, dust and debris.
 - b Correct and repair any problems, and replace worn equipment.
 - c Keep tension at the floor blocks adjusted to minimize hand line slack.
 - d Keep rope locks properly adjusted.
- 2.1.2 REGULAR OBSERVATIONS should be made in addition to regularly scheduled inspections whenever the system is being operated. Ask the following question each time the set is operated. If the answer to any of these questions is 'no', **HALT OPERATION IMMEDIATELY UNTIL THE PROBLEM(S) IS CORRECTED.**
- a Is the set correctly balanced?
 - b Is the rope lock adjusted properly?
 - c Does the system move freely without excessive friction?
 - d Is the system too hard to operate?
 - e Are the arbor gates securely closed to retain the counterweights?
 - f Are there any obstructions present or line problems?

2.2 Routine Inspection

Perform Routine Inspection

- Every 12 months.
- Whenever you notice signs of damage or poor operation.
- Whenever you have, or think you may have, overloaded or shock loaded the system.

Figure 5 – Broken Wires

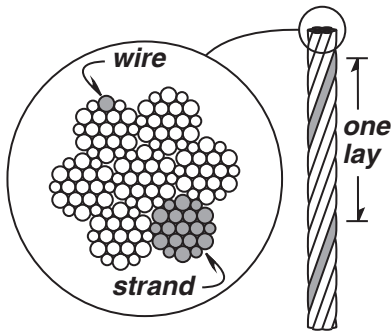

Wire rope assembly must be replaced if more than 6 wires are broken in one lay, or if more than 3 wires are broken in one strand in one lay.

Figure 6 – Rope Diameter

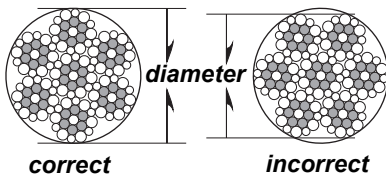

The wire rope assembly must be replaced if the diameter measures less than the minimum diameter at any point.

wire rope size	minimum diameter
1/8 in	7/64 in (.1094 in)
3/16 in	11/64 in (.1719 in)
1/4 in	15/64 in (.2344 in)
5/16 in	19/64 in (.2969 in)
3/8 in	11/32 in (.3438 in)

An inspection form should be created which covers the components of your system and operation. The following list provides an overview of the items you should be looking for when doing an inspection.

2.2.1 Lift Lines (Wire Rope)

- Always wear protective clothing when handling wire rope.
- Check the entire length of wire rope for bent wires, crushed areas, broken or cut wires, corrosion, and other damage. Carefully inspect areas that pass over sheaves or through guides.
- Make sure terminations are tight, properly applied, and free of wear, cracks and other damage.
- Make sure turnbuckles are adjusted correctly and safety wired.
- Place enough weight to keep the wire rope straight and tightly drawn. Measure the diameter of the wire rope, especially in areas where wear is noticeable. Replace the wire rope if the diameter measures below minimum diameter at any point. See Figure 6.

2.2.2 Hand Lines

- Check for abrasions, overly smooth or glossy areas, kinking, stress points, rot or dry rot.
- Check connections for corrosion or signs of wear.

2.2.3 Rope Locks

- Check that mounting is secure.
- Check to make sure adjustment is correct. See Section 2.4.
- Check all components for signs of wear or damage.
- Refer to the rope lock owner's manual.

2.2.4 Head, Loft and Floor Blocks

- Check that mounting is secure.
- Inspect bearings and shafts for signs of wear or damage.
- Check for over-tightened shaft bolts that prevent sheave from turning.
- Check sheave grooves for signs of wear, cracking or damage.

2.2.5 Arbor and Counterweights

- Check condition on the top and bottom connections.
- Check to make sure all bolts and nuts are tight and secure.
- Check the front arbor gate, make sure it closes completely and securely.

2.2.6 Arbor Guides

- Check guide shoe for signs of wear.
- Clean guides (do not lubricate) as required.
- Check to be sure the joints match and are straight.

2.3 Testing the System

Important!

- Movement will become harder at the ends of travel. This is normal and results from the transferred weight of the cables.

The system should be tested at least annually. The following procedure is recommended.

- 2.3.1 CARRY OUT A COMPLETE INSPECTION of the system you are testing.
- 2.3.2 REMOVE ALL ITEMS suspended from the battens. Testing should be conducted using 'pipe weight' (only enough weight to balance the empty pipe).
- 2.3.3 ONCE THE ARBOR IS SET to balance an empty batten, run the batten through its full range of movement, up to its high trim and down again. Repeat several times. Listen for unusual noises including rubbing lines.
- 2.3.4 IF OPERATION OF THE SET IS DIFFICULT at any point of travel, there may be a problem that requires correction. Thoroughly check all guides and cables. If you are unable to determine the cause of the problem, contact your stage rigging contractor or Thern Stage Equipment.

Frequent Wire Rope Inspection:

- Use ASME B30.7 as a guideline for rope inspection, replacement and maintenance.
- Check the wire rope, end connections and end fittings for corrosion, kinking, bending, crushing, birdcaging or other signs of damage.
- Check the number, distribution and type of visible broken wires. See paragraph 2.2.1 and Figure 5.
- Check the wire rope for reduction of rope diameter from loss of core support, or wear of outside wires. See Figure 6.
- Take extra care when inspecting sections of rapid deterioration such as sections in contact with saddles, sheaves, repetitive pickup points, crossover points and end connections.

2.4 Testing the Rope Locks

- 2.4.1 WITH A BALANCED SYSTEM, testing should be conducted using 'pipe weight' (only enough weight to balance the empty pipe).
- 2.4.2 RAISE THE BATTEN to its high trim, and then lower until the arbor is about one foot above the bottom stop.
- 2.4.3 CLOSE THE ROPE LOCK and secure the handle.
 - a ADD 50 POUNDS OF WEIGHT to the arbor. If the arbor moves at all before all weight is added, the lock setting is too loose and should be tightened.
 - b IF YOU CAN ADD MORE THAN 50 POUNDS of weight and the arbor does not move at all, the lock setting is too tight and should be loosened.
 - c REPEAT THESE STEPS as necessary until the lock allows hand line to slip at about 50 pounds.

2.5 Repairing the Rigging System

- 2.5.1 GET FACTORY AUTHORIZATION for all repairs. Unauthorized repairs will void the warranty and may lead to damage or failure of the equipment.
- 2.5.2 REPLACE DAMAGED OR POORLY OPERATING PARTS with Thern repair parts.
- 2.5.3 REFINISH AREAS where the paint is worn or flaking. A good finish helps to protect against corrosion.
 - a REMOVE THE FINISH from damaged areas, down to the bare metal.
 - b CLEAN THE AREA thoroughly.
 - c REPAINT with a high quality primer and finishing coat.
- 2.5.4 TO ORDER REPAIR PARTS, please contact the Thern factory. Include the following information when ordering:
 - part number
 - description of what happened, or what is wrong
 - your name and return address

TSE **THERN**
STAGE
EQUIPMENT

A division of:
Thern, Incorporated
5712 Industrial Park Road
Winona, MN 55987

PHN 800-553-2204
FAX 507-454-5282

EMAIL: info@thernstage.com
www.thernstage.com