

- H - HEAD
- B - BLOCK
- # - SHEAVE DIAMETER
- SHEAVE DIAMETER
- R - UPRIGHT MOUNTING
- # - NUMBER OF GROOVES
- N - SHEAVE MATERIAL (N=NYLATRON, S=STEEL)
- # - ROPE SIZE (LIFT LINE)
- D - DOUBLE
- P - PURCHASE

MODEL	CAPACITY	DIM A	DIM B	WEIGHT
HB12-R6N25DP	2500 LBS	2.21 [ 56mm]	5.00 [127mm]	61.87 LBS
HB12-R8N25DP	2500 LBS	3.08 [ 78mm]	5.88 [150mm]	66.10 LBS
HB12-R10N25DP	2500 LBS	3.96 [101mm]	6.75 [172mm]	70.27 LBS
HB12-R6S25DP	2500 LBS	2.21 [ 56mm]	4.98 [127mm]	79.14 LBS
HB12-R8S25DP	2500 LBS	3.08 [ 78mm]	5.88 [150mm]	86.62 LBS
HB12-R10S25DP	2500 LBS	3.96 [101mm]	6.75 [172mm]	93.98 LBS

NOTES:

1. MAXIMUM RATED CAPACITY :
  - MAY EXCEED CAPACITY OF THE ROPE.
  - USE ROPE MANUFACTURER'S RATING AND SAFETY FACTOR TO DETERMINE LOAD LIMIT.
  - WHEN PROPERLY INSTALLED, MAINTAINED AND OPERATED.
2. MOUNTING HARDWARE MUST BE DISTRIBUTED EVENLY.
  - MINIMUM OF 4 ATTACHMENT POINTS.
3. CONTACT FACTORY FOR NON-STANDARD REQUIREMENTS.

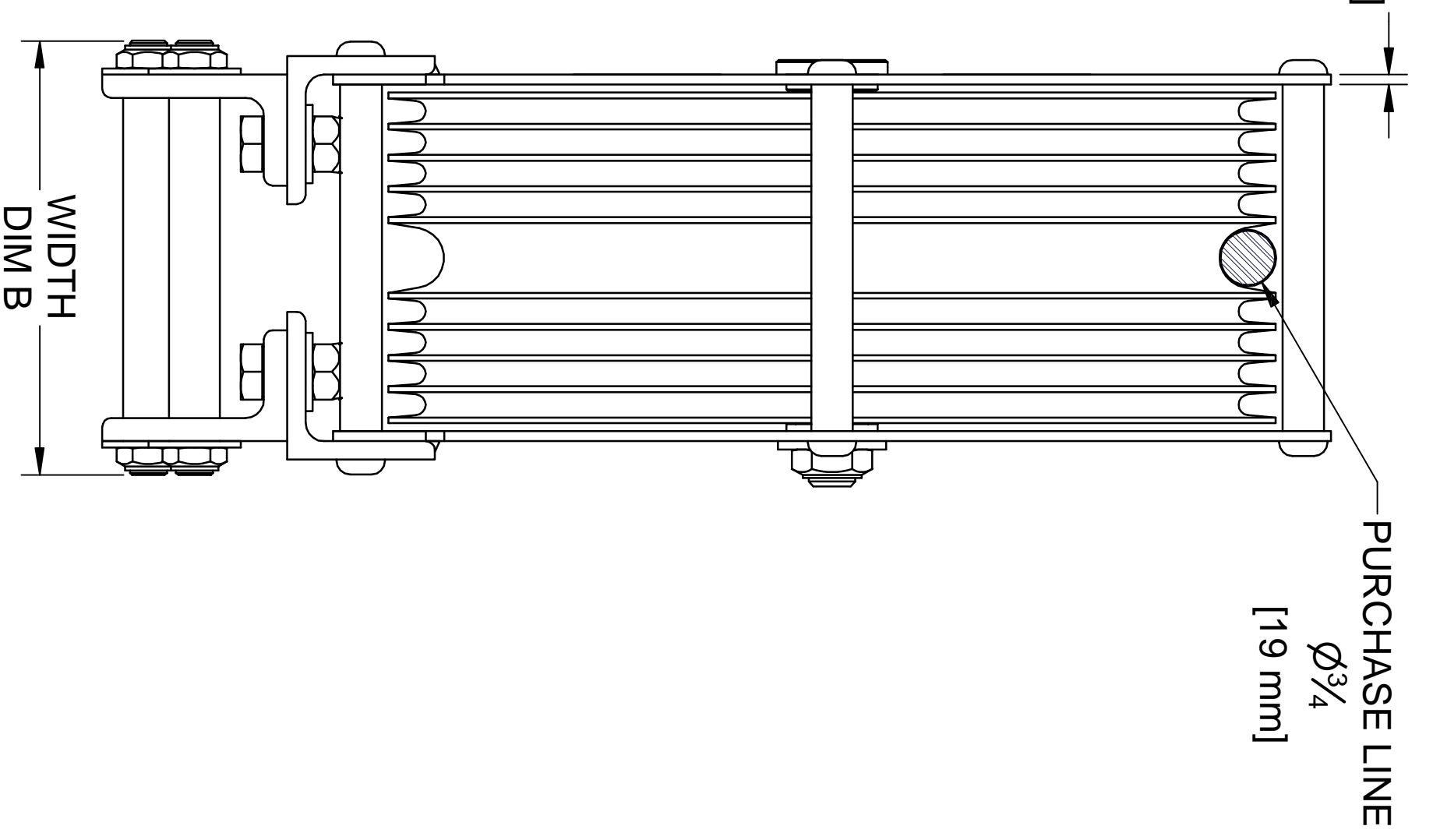
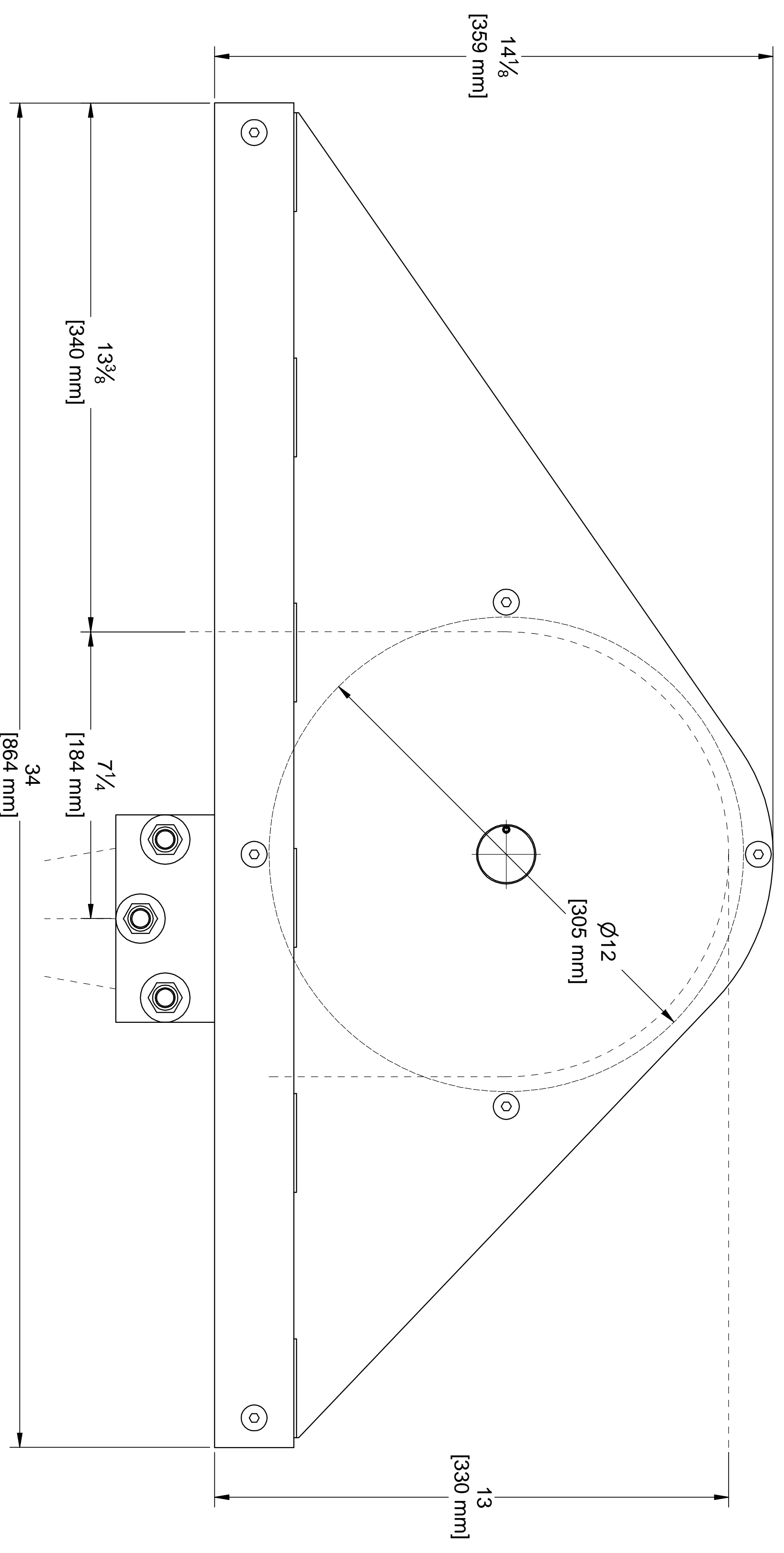
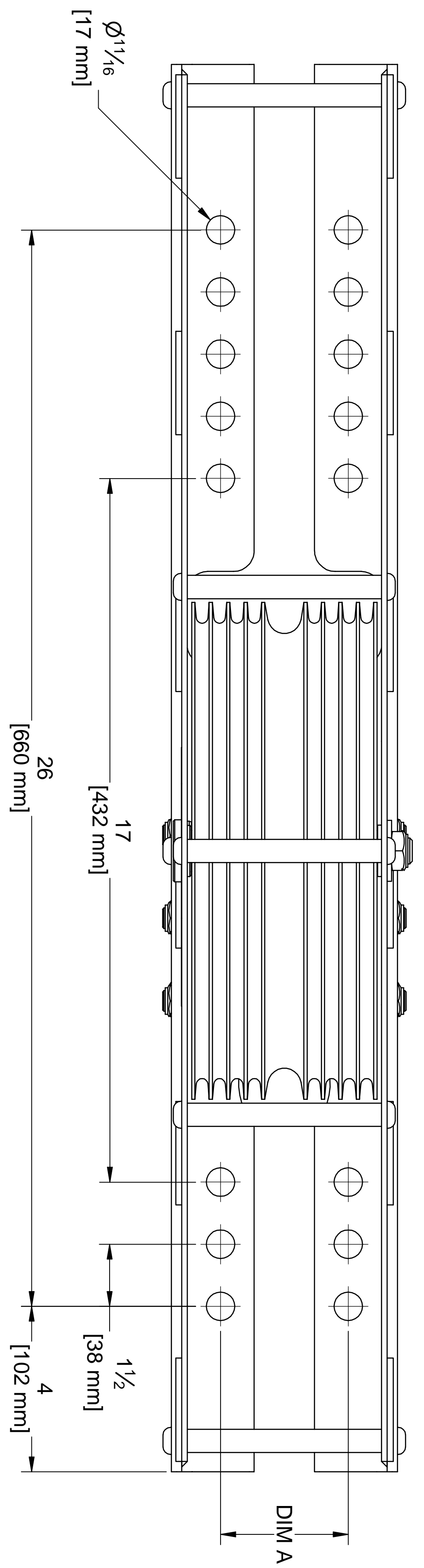

REVISIONS

REV	DATE	ENGINEER	DESCRIPTION	REVISION

DRAWINGS FOR PRODUCTION APPROVAL. COMPANY NAME \_\_\_\_\_  
 MANUFACTURE WILL NOT BEGIN UNTIL PRINT NAME \_\_\_\_\_  
 APPROVED DRAWING IS RETURNED TO THERN INC. SIGNATURE \_\_\_\_\_  
 DATE \_\_\_\_\_

DESCRIPTION: DIMENSIONAL DRAWING

MODEL	FINISH	SCALE	DATE	PART NO
12" HEAD BLOCK UPRT DP	FINISH	N/A	10/28/2015	D4522

RETURN TO: THERN INC. 5712 INDUSTRIAL PARK ROAD, P.O. BOX 517, PHOENIX, AZ 85027  
 PHONE: 602-446-2886 FAX: 602-446-5282

TOLERANCES UNLESS OTHERWISE SPECIFIED: DIM. # 1 1/2 DON'T SCALE DRAWING

THIS PRINT IS THE PROPERTY OF THERN INC. AND IS TO BE RETURNED TO THERN INC. PART WITHOUT WRITTEN APPROVAL BY THERN INC.

REVISIONS: SEE TABLE  
 DRAWN BY: JCA  
 SCALE: N/A  
 DATE: 10/28/2015

